

**Vocational Higher Secondary  
Education (VHSE)**

**Second Year**

**ELECTRICAL AND ELECTRONICS  
TECHNOLOGY**

*Reference Book*



Government of Kerala  
Department of Education

State Council of Educational Research and Training (SCERT),  
KERALA  
2016

## List of Contributors

### Participants

**Deepa. G**

Vocational Teacher, E.V.H.S.S, Elamannoor, Pathanamthitta

**Shaji. B**

Vocational Teacher, R.V.H.S.S, Konni, Pathanamthitta

**Murali. G**

Vocational Teacher, SV.V.H.S.S, Thamarakkudy, Kollam

**Nidhin Mohan**

Vocational Teacher, SNDPVHSS, Adimali

**Praveen Kumar G.S**

Vocational Instructor, VVHSS, Olathanni.

### Experts

**S. Muhammed Kasim (Rtd. Prof)**

Dept. of EEE, T.K.M. C.E, Kollam.

**Dr. D. P. Balachandran (Rtd.Prof)**

Dept. of EEE, College of Engineering  
Thiruvananthapuram.

**J. Jayaraj**

Lecturer in Electrical Engg.  
WPTC, Kaimanam, Thiruvananthapuram

**Prem Kumar. K**

Scientist, ANERT, Thiruvananthapuram

**K.G Madhu**

Managing Director  
Ammini Solar (Pvt.ltd), Pappanamkodu, Industrial Estate  
Thiruvananthapuram

### Academic Co-ordinator

**Dr. Ancey Varughese**

Assistant Professor, SCERT

*Prepared by :*

**State Council of Educational Research and Training (SCERT)**

Poojappura, Thiruvananthapuram 695012, Kerala

Website : [www.scertkerala.gov.in](http://www.scertkerala.gov.in) e-mail : [scertkerala@gmail.com](mailto:scertkerala@gmail.com)

Phone : 0471 - 2341883, Fax : 0471 - 2341869

Typesetting and Layout : SCERT

© Department of Education, Government of Kerala

## Foreword

Dear Learners,

*This book is intended to serve as a ready reference for learners of vocational higher secondary schools. It offers suggested guidelines for the transaction of the concepts highlighted in the course content. It is expected that the learners achieve significant learning outcomes at the end of the course as envisaged in the curriculum if it is followed properly.*

*In the context of the Right- based approach, quality education has to be ensured for all learners. The learner community of Vocational Higher Secondary Education in Kerala should be empowered by providing them with the best education that strengthens their competences to become innovative entrepreneurs who contribute to the knowledge society. The change of course names, modular approach adopted for the organisation of course content, work-based pedagogy and the outcome focused assessment approach paved the way for achieving the vision of Vocational Higher Secondary Education in Kerala. The revised curriculum helps to equip the learners with multiple skills matching technological advancements and to produce skilled workforce for meeting the demands of the emerging industries and service sectors with national and global orientation. The revised curriculum attempts to enhance knowledge, skills and attitudes by giving higher priority and space for the learners to make discussions in small groups, and activities requiring hands-on experience.*

*The SCERT appreciates the hard work and sincere co-operation of the contributors of this book that includes subject experts, industrialists and the teachers of Vocational Higher Secondary Schools. The development of this reference book has been a joint venture of the State Council of Educational Research and Training (SCERT) and the Directorate of Vocational Higher Secondary Education.*

*The SCERT welcomes constructive criticism and creative suggestions for the improvement of the book.*

With regards,

**Dr. P. A. Fathima**  
Director, SCERT, Kerala

## CONTENTS

<b>1. About the Course .....</b>	<b>5</b>
<b>2. Major Skills .....</b>	<b>5</b>
<b>3. Syllabus .....</b>	<b>6</b>
<b>4. Module : 3</b>	
<b>Solar PV System Installation and Maintenance .....</b>	<b>9</b>
1. Unit 1 : Cells and Batteries .....	9
2. Unit 2 : Electronic Components and Devices II .....	24
3. Unit 3 : Solar PV System Installation and Maintenance .....	47
4. List of Practical Activities - Module : 3 .....	72
<b>5. Module : 4</b>	
<b>Servicing of Common Home Appliances .....</b>	<b>73</b>
1. Unit 1 : Electrical Machines .....	73
2. Unit 2 : Servicing of Common Home Appliances .....	89
3. Unit 3 : Engineering Graphics .....	103
4. List of Practical Activities - Module : 4 .....	134
<b>6. References .....</b>	<b>135</b>

## ABOUT THE COURSE

The course named Electrical and Electronics Technology (EET) comes under engineering group. Electrical and Electronics Engineering field has radically transformed our way of life and so the basic concepts of the same have been dealt with in detail. Students with a flair for LED assembling and repairing, solar PV system installation & maintenance, domestic appliance servicing and wiring will find the course a rewarding career option. Besides this, students can stabilize their career by equipping themselves with wire man license. This can open the portals of self-employment to the pass outs. For those aspiring to apply for government jobs, the course is recognized by PSC and so it opens job opportunities. There are ample opportunities in private sectors too. Due priority is also given to skill development to ensure that students don't take a back seat on their ride to success. So the future seems promising for EET students.

The course EET ensures a radical change at the academic level and so is all geared to set a new mile stone for its students. Our prime focus is on developing much needed man power in industries and opening up opportunities for self-employment.

The much awaited syllabus revision has distanced the stagnancy that the course had been in for a long time. Bridging the gap between current industry requirement and skill competency of students is a herculean task. We believe that we have done justice to this issue and addressed it by taking a small step forward. All credit goes to replacing obsolete syllabus with portions incorporating current technology and industry requirement. This seems to be the only sensible solution. Practical skills of students should also be enhanced by paying more attention to hands-on-training.

### Major Skills (with sub skills)

#### Module - 3

##### Solar PV system installation and Maintenance

- Servicing of Lead acid Batteries.
- Identification of active electronic components.
- Testing of active electronic components.
- Assembling of simple amplifiers and inverters.
- Designing of Solar PV System.
- Installation of Solar PV System.
- Servicing of Solar PV System.

**Module - 4****Servicing of common home appliances**

- Identification of different D C motors.
- Identification of different single phase induction motors.
- Connection of DOL and Star Delta starters.
- Servicing of Electric iron.
- Servicing of Electric water heater.
- Servicing of Ceiling fan.
- Servicing of Pedestal fan/Wall mount fan
- Servicing of Mixer grinder (Mixy)
- Servicing of Wet grinder.
- Servicing of Washing Machine.
- Servicing of Water pumps.
- Drawing engineering graphics.
- Familiarising Electrical AutoCAD.

**SYLLABUS****Module - 3 (Solar PV system installation and Maintenance)****Unit -1 Cells and Batteries****(55 Periods)**

Cells- concepts of Primary and secondary Cells- Lead Acid Cell- Steps of Construction, Defects, Self discharge/shelf life, Capacity and efficiency of battery, Charging and Discharging, Care and Maintenance, Interconnection of Cells- Series and parallel, Instruments and tools used for battery testing, Battery bank installation, testing and commissioning. Types of lead acid battery- Liquid vented, Tubular- Sealed or VRLA - AGM & Gel, Applications of Nickel cadmium & Lithium ion cells.

**Unit -2 Electronic components and Devices - II****(85 Periods)**

Transistor-types, testing connections-Transistor as an amplifier, Basic oscillator circuit, SCR-TRIAC-DIAC-FET-MOSFET-IGBT-terminals-applications and testing. Zener diode-voltage regulator using zener diode and 78XX series- applications of LCD-photodiode-photo transistor, Thermistor, LDR, Super capacitor. Inverter & UPS - Basic circuit and working - Familiarising inverter circuit using MOSFET/IGBT.

Number systems- binary and decimal - Logic gates-AND, OR, NOT, NAND, NOR & XOR

**Unit - 3 Solar PV System installation and maintenance (200 Periods)**

Introduction to Energy- Renewable and non-renewable energy sources-Energy situation in Kerala and contribution of different energy sources to the energy mix.

Solar Energy- Advantages and disadvantages (5)

Solar PV Modules- Photo Voltaic effect-Solar cells-Construction , Series and Parallel connections of solar cells, fabrication of solar PV module. Mismatch in cells/module, Shading and hot spots. Factors affecting power of a PV Module. Rating of PV Module.

I-V characteristics of PV module- Open circuit voltage-Short circuit current and maximum power point , Selection of solar module according to requirement. (60)

Solar PV system and its installation- Components of solar PV System- Choice of batteries for PV modules.DC to DC Converter, Inverter (DC to AC converter), Charge controllers, Wire sizing in PV systems. Types of PV Systems- Stand alone, Grid connected and Hybrid system. Installation of PV module - Orientation and inclination requirements- Module mounting structures- Selection of appropriate equipment, materials, accessories and tools for installation of battery , inverter and other support systems. Safety precautions for installing a solar photo voltaic system. (100)

Solar PV system maintenance -Basic Maintenance-cleaning of module and maintenance of battery. (20)

Solar PV devices - Solar lantern, Solar Street lights - Parts & Working. (15)

**Module - 4 (Servicing of common home appliances)****Unit - 1 Electrical Machines (50 Periods)**

**DC Machines-** DC Generator- Parts, Working principle, Types - DC Motors- Working principle, Types Applications-necessity of starters.

**A.C Motors** -Principle of working and types of 3 phase Induction motors- Starters- Connection of DOL and Star delta starter-Single phase Induction Motor-Types- Working -Circuit Diagram and Applications of PSC, CSIR, Universal, Shaded pole, Stepper motor and BLDC Motors.

**Unit - 2 Servicing of common home Appliances (200 Periods)**

Parts, working, testing, precautions and servicing of :

1. Electric iron- Non Automatic and Automatic
2. Electric Water Heater-.

3. Ceiling fan
4. Wall mount/Pedestal fan
5. Mixer Grinde
6. Wet grinder
7. Washing Machine - Semi and Fully automatic
8. Water pump-Centrifugal and Jet.

**UNIT - 3 Engineering Graphics****(90 Periods)****Engineering drawing**

Engineering drawing- Uses-Instruments- Types of lines, Lettering and dimensioning, Geometrical construction -bisecting lines- perpendiculars- dividing line into equal parts, Angles. Construction of triangle, square, rectangle, pentagon and hexagon. Conic sections-concept - definition of ellipse, helix, parabola & hyperbola , construction of ellipse, parabola. Involute, triangle & square .Projections of points & lines. Projection of planes (first quadrant only). Orthographic Projection - Orthographic views of simple objects- Pictorial Drawing-Isometric projection- Principle, isometric scale, isometric view. Auxiliary views, Free hands sketching of straight lines, rectangles, squares, circles- Sectional views of simple engineering components and devices. Development of surfaces -concept & applications- development of cylinder and pyramid.

**Computer Aided Drafting**

Introduction to CAD -starting to use CAD software- Application of CAD in Engineering drawing -opening of CAD-Setting of units and limits-saving of drawing. Draw commands (lines, circles, arc, ellipse, hatch, modify, erase, etc.) Dimensioning and text commands. Drawing of 2D figures, creating a new drawing. Introduction to electrical Auto CAD. Familiarise & practice electrical Auto CAD software.



## Module - 3

### Solar PV system installation and Maintenance

#### Module Overview

The Third module of EET named SOLAR PV SYSTEM INSTALLATION & MAINTENANCE consists of three units such as cells and batteries, electronic components and devices-II and solar PV system installation and maintenance. Cells and batteries deals with the concepts of primary and secondary cells, construction, maintenance and charging of lead acid cells etc. Electronic components and devices includes identification and testing of electronic components such as transistors, SCR, TRIAC, DIAC, FET, MOSFET etc, fabrication and working of voltage regulators, amplifiers and basic inverter circuits. The third unit deals with the concept of solar energy, solar cells, Rating, configuration and installation and maintenance of PV systems. Maintenance of commonly used solar PV devices is also included in this module.

#### Unit - 1

#### Cells and Batteries:

##### Introduction

Cells and batteries is the first unit in the third module. This unit is very significant being the part of solar PV System. The unit comprises of construction, maintenance, connections & types of lead acid cells (Liquid vented and maintenance free). The charging and discharging methods and testing of lead acid battery is also dealt with. The applications, advantages and disadvantages of nickel cadmium and lithium ion cells are also included.

##### Learning Outcomes

After completion of this unit, the learner:

- Explains the concept of Primary & Secondary cells.
- Explains the construction of lead acid cell.
- Undertakes charging and discharging of lead acid cell.
- Realises the defects, capacity and efficiency of lead acid cell.
- Under takes interconnection of cells in series and parallel.
- Undertakes battery bank installation, testing and commissioning.
- Undertakes maintenance of different batteries.
- Realises the application of different batteries.

## Concept Detailing

### Lead Acid Cell

#### Parts of lead acid cell

a) **Container**

The container is made of hard rubber which accommodates plates, separators, electrolyte etc.

b) **Plates (electrodes)**

The active material of positive plate of the cell is lead peroxide ( $\text{PbO}_2$ ) and that of negative plate is spongy lead ( $\text{Pb}$ ). The plates are made up of lead antimony grid plates and the surface of the plates is packed with paste of active materials. The positive plates are so arranged that they are in between the negative plates. So the number of the negative plates is always one greater than that of positive plates. The colour of  $\text{PbO}_2$  plate is chocolate brown and that of negative plate is grey.

c) **Electrolyte**

Dilute sulphuric acid ( $\text{Dil. H}_2\text{SO}_4$ ) is used as the electrolyte. Usually the proportion of acid and water is 1: 3.

d) **Separators**

These are used to prevent electrical contact between positive and negative plates. Separators are placed in between the plates and the electrolyte should be able to pass through the separators. They are made up of perforated rubber, specially treated wood, celluloid etc.

e) **Cell cover**

It is made up of hard rubber and is seated to cover the cell. They prevent spitting of acid.

f) **Vent plugs**

It is provided on the cell cover so that the gases formed during chemical reaction is escaped through this. It is also used for pouring distilled water and acid whenever necessary. The specific gravity of the electrolyte inside the cell can be measured through this vent hole using hydro meter.

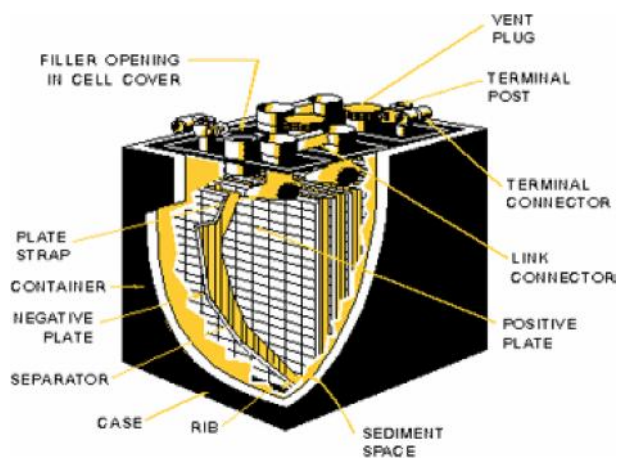

**g) Plate connector**

They are made up of pure lead. Positive and negative plates are welded separately with it forming positive group and negative group terminals. An extension from each connecting bar forms the terminal pole.

**h) Cell connector**

One cell is connected to the next by a cell connector to form a battery.

**D) sealing compound**

It is used to form an acid tight joint between the cover and the container.

**j) Ribs and mud house**

There is space provided at the bottom of the plates to collect the deposits of the chemical reaction. This arrangement is called mud house. Mud house is formed between two ribs at the bottom of the container.

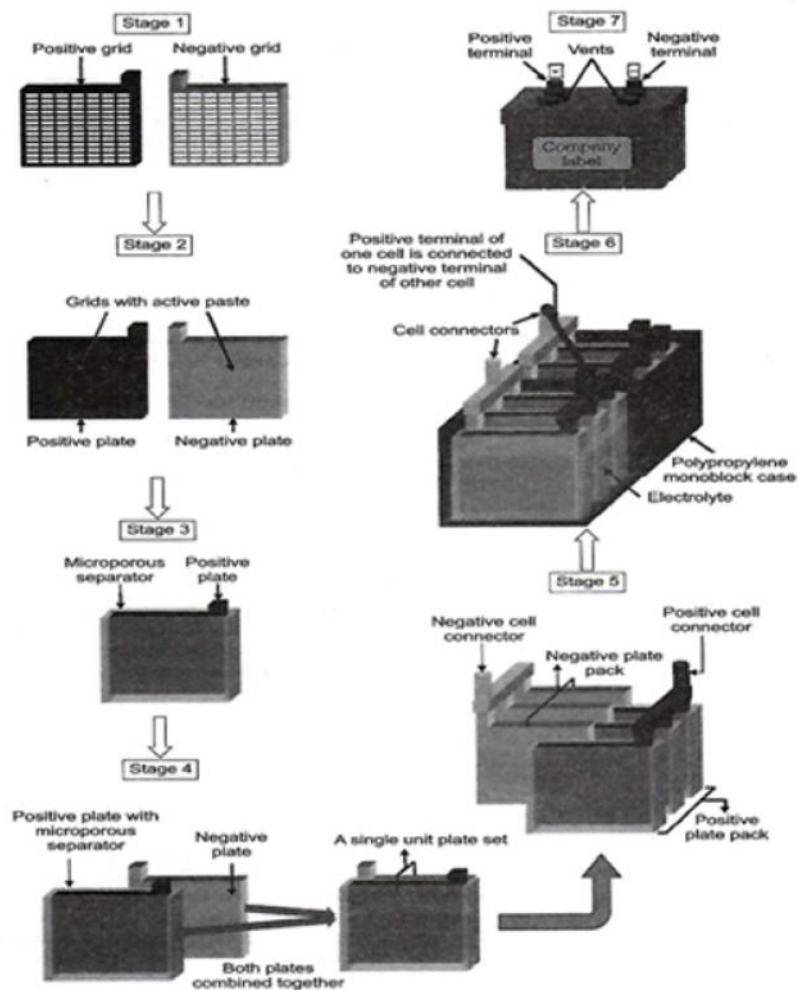
**Steps of construction of battery**

**The battery manufacturing process involves the following steps**

- 1) Casting the positive and negative grids.
- 2) Applying the active material (pasting) on the grids.
- 3) Covering the positive plate with micro porous separators
- 4) Combining the positive and negative plates
- 5) Arrange the plate sets and form the plate blocks
- 6) Forming cells and filling the electrolyte
- 7) Finalizing battery (carrying out initial charging (forming), testing, closing vent plugs, cleaning and sticking labels).

**Care & maintenance of a lead acid battery**

The maintenance of battery is very important as it increases the life of the battery. Battery maintenance depends on the type of battery used. Physical maintenance includes cleaning of contact points, checking of specific gravity, observation of charging and discharging cycles. Before doing maintenance, the battery should be disconnected from the circuit. While maintaining battery, the following points should be observed.

- Level of the electrolyte should always above the plates.
- During charging vent plugs should kept open.
- While preparing the electrolyte, water should not be poured into acid, but acid should be added to water drop by drop.
- While preparing the electrolyte the ratio of acid and water should be 1:3
- Evaporation of the electrolyte should be compensated by adding distilled water.
- Battery should not be kept in discharged condition for a long period.
- Open flames near the battery should be avoided.
- Charging and discharging should be at normal current rate.
- No metal object should contact the battery terminals which causes short circuit.
- Charge the battery with the specified charger only
- Battery should be kept clean and dry.

**Chemical reaction during charging and discharging of Lead acid cell**

The chemical reaction in a lead acid cell is reversible (bi directional)

**a) Discharging**

When a fully charged battery is put into use, (ie. connected to a load) a current flows through the electrolyte and dilute  $\text{H}_2\text{SO}_4$  decomposes giving  $\text{H}^+$  ions and

$\text{SO}_4^{--}$  ions. The  $\text{H}^+$  ions move towards the positive  $\text{PbO}_2$  plate ( anode) and  $\text{SO}_4^{--}$  ions move towards the negative Pb plate ( cathode ).

Electrolyte

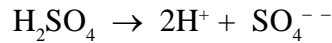

At anode

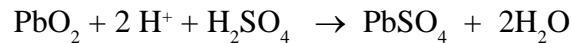

At cathode

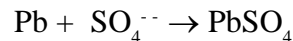

As water ( $\text{H}_2\text{O}$ ) is formed during discharging, the specific gravity of electrolyte is decreased. Also the positive ( $\text{PbO}_2$ ) plate and negative (Pb) plates are converted into lead sulphate ( $\text{PbSO}_4$ ) which is white in colour. The voltage of the battery also decreased during discharging.

### b) Charging

When DC supply is passed through the cell, dilute  $\text{H}_2\text{SO}_4$  decomposes giving  $\text{H}^+$  ions and  $\text{SO}_4^{--}$  ions, The  $\text{H}^+$  ions move towards negative plate and  $\text{SO}_4^{--}$  ions move towards positive plate.

Electrolyte

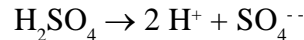

At anode



At cathode

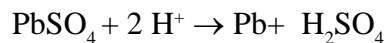

During charging the concentration of electrolyte (specific gravity) is increased. The plates changes back into  $\text{PbO}_2$  (lead peroxide ) which is chocolate brown in colour and Pb ( spongy lead ) which is grey in colour. Voltage of the cell is increased.

In lead acid cells, hydrogen gas is liberated at negative plates (cathode) and oxygen gas is liberated at positive plates. (anode)

### Indications of a fully charged battery

#### 1) Visual indication

a) Colour of the electrodes

By observing the colour of the electrodes we can examine whether the battery is fully charged or not. If the battery is fully charged, positive plate will be of chocolate brown colour and the negative plate will be of grey colour. If the battery is discharged both the plates will be of white in colour.

### b) Gassing at the electrodes

When the battery is fully charged gases will be evolved at the electrodes. Hydrogen gas is liberated at negative plate and oxygen gas is liberated at positive plate. So gas bubbles at the electrode is an indication of a fully charged battery.

### 2) Electrical indications

By measuring the voltage of the battery, we can examine whether the battery is fully charged or not. If the voltage of the cell is 2.1 V, it is fully charged and 1.8 V if it is discharged.

Current (Ampere Capacity) can also be measured. If the meter shows a steady reading, it is fully charged.

### 3) Physical indication

By measuring the specific gravity of the electrolyte using hydrometer, we can examine whether the battery is fully charged or not. If the specific gravity is between 1.26 - 1.28 on a hydrometer scale, it is fully charged and if it is 1.15 - 1.20 (1.5 to 1.2), it is fully discharged.

*Activity: Collect a lead acid battery, Check its voltage/cell and specific gravity. Dismantle it and note the colour of the plates. Note down your observation in a table. State the conditions of the cell.*

### Life cycle of a battery

One charging and discharging operation of a battery is referred as one cycle of battery. Due to each charge-discharge cycle, the capacity of battery decreases slightly. Typically the life cycle of a lead acid battery is 500 - 800 cycles.

### Charging Methods

Generally there are two types of charging such as constant current and constant voltage method.

#### Constant current method

In this method of charging the batteries are connected in series and connected to a circuit as shown in fig. The charging current is kept constant throughout the charging period by adjusting the rheostat in the circuit as the battery voltage goes up.

In order to avoid excessive gassing or over heating the charging may be carried out in two steps, an initial charging of comparatively higher current and a finishing rate of low current. The current at which the battery is charged is decided by the ampere hour capacity. Usually the charging current shall be  $1/8^{\text{th}}$  of the Ah capacity.

During the charging period, the temperature of the electrolyte should not exceed beyond  $40^{\circ}$  to  $45^{\circ}\text{C}$  because of the danger of plate buckling. So the temperature of electrolyte is carefully watched and if the temperature approaches danger limit the charging current should be reduced.

Constant Current Method

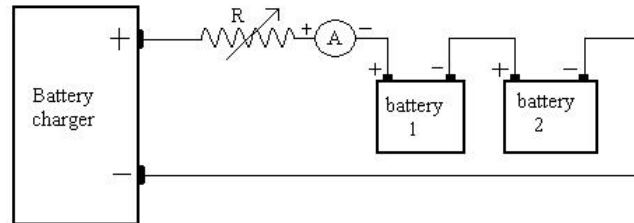

In this system, a number of batteries can be connected in series with the battery charger. The voltage of the battery charger should be greater than the total voltage of the battery. Otherwise the battery will discharge through the circuit. This type of charging system is used only for

- 1) Newly constructed battery
- 2) Completely discharged battery
- 3) Battery which is kept idle for a long period.

## 2. Constant voltage method

In this method, the voltage of the battery is kept constant by varying the current. Initially the charging current is very high and decreases as the battery charges. The time of charging is reduced to half and increases the capacity compared to constant current method. But the efficiency is low.

constant voltage method

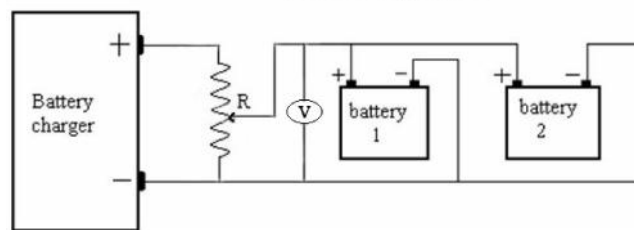

## 3. Trickle charging

Due to leakage action and other open circuit losses, a fully charged battery loses its charge even when open circuit. Hence to keep the battery always in charging condition, the battery is charged by a very small current for a long period. This type of charging is called trickle charging.

**Activity:** Charge a discharged lead acid cell. How will you identify its full charge condition?

### Capacity of a battery

It is the useful quantity of electricity that can be taken from a battery at the specified rate of discharge before its voltage falls to the specified value. The capacity of a battery is expressed in Ampere- Hour (Ah).

If a battery can deliver one ampere current for one hour, its capacity is one ampere-hour.

$$\text{C. rating (ampers)} = \frac{\text{Capacity}}{\text{No. of hours for full charge or discharge}}$$

### Factors affecting capacity of battery

- Number of plates connected as one unit in cell
- Size of plate connected as one unit in cell
- Rate of discharge
- Amount and density of electrolyte
- Temperature

### Efficiency of a battery

There are two types of efficiency

- a) Ampere Hour efficiency
- b) Watt Hour efficiency

#### Ampere Hour efficiency

Ampere Hour efficiency is the ratio of ampere hour on discharge to ampere hour on charge.

$$\text{Ampere Hour efficiency} = \frac{\text{Ampere hour on discharge}}{\text{Ampere hour on charge}}$$

Watt Hour efficiency is the ratio of energy (watt hour) during discharge to the energy (watt hour) during charge.

$$\text{Watt Hour efficiency} = \frac{\text{Watt hour on discharge}}{\text{Watt hour on charge}}$$

Watt hour efficiency of a battery will always be less than its ampere hour efficiency because discharge voltage is less than charge voltage.



### Factors affecting efficiency of a cell

- Charging rate
- Discharging rate
- Internal resistance
- The period of time between the end of discharge and starting of recharge
- Temperature

#### *State of Charge (SoC) and Depth of Discharge (DoD) of a battery.*

*SoC indicates the level of charge (Percentage of total charge) stored at that time in a battery. DoD is the inverse of SoC.*

$$DoD (\%) = 100 \% - SoC (\%)$$

### Internal Resistance of a cell

It is the resistance offered by the cell to the flow of current. A cell possesses internal resistance because of the resistance of

- Electrolyte
- Electrodes
- Terminals of the battery

The factors affecting internal resistance of a cell are

- a) Size of electrodes
- b) Distance between the plates
- c) Number of electrodes

### Defects of secondary cell

#### 1) Sulphation

If a cell is over discharged or keep the discharged cell for a long period, both plates become covered with sulphate crystals. The effect is usually noticed by a whitish colour on plates.

To avoid sulphation

- Avoid over discharging
- Recharge soon when a battery is discharged
- Add carbonate of soda to electrolyte
- Trickle charge the battery

#### 2) Buckling of plates

This is a trouble in which plates bend due to over charge or over discharge. It can be avoided by normal charging and discharging of a cell. If the battery has a buckled plate, it must be replaced.

### 3) Sedimentation

Due to overcharging & over discharging or due to continuous use, small parts from the plate break and keep on depositing at the bottom. After some time this deposited material starts short circuiting. If it happens, replace the electrolyte and clean the bottom surface.

#### Self Discharge/ Shelf life

It is the charge consumed when battery is not in use for a long time, i.e. sits on the shelf. The reason for self discharge is the electrochemical process within the cell. Self discharge of battery increases with increase in temperature of battery. Therefore it is recommended to store batteries at optimum temperature to reduce self discharge and to increase efficiency.

The rate of self discharge depends upon the type of battery. Lead acid battery loses 50 % of the stored charge in 3 to 4 months. Li-ion cells stored at 30°C typically lose 25% of the stored charge in 3 months and Ni-Cd loses the same charge within 3-4 weeks.

#### Connection of Battery

##### a) Series connection

If the negative terminal of first battery is connected to the positive terminal of the second battery and negative of the second battery to positive of the third and so on, such connection is called series connection. In this connection the total voltage is the sum of the individual battery voltages. But same current flows in all the batteries. Due to this the charge capacity of series connected batteries is as same as the charge capacity of a single battery.

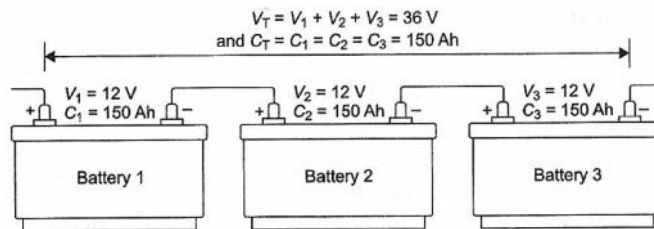

##### b) Parallel connection

If the positive terminals of all batteries are connected together and negative terminals of all batteries are connected together,

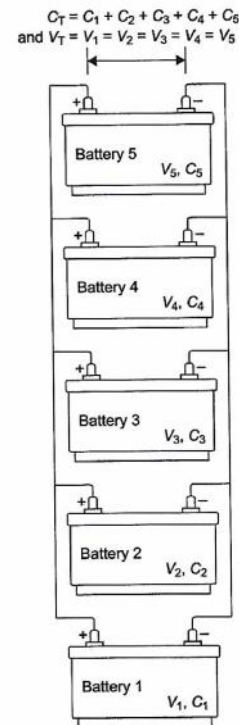

such connection is called parallel connection. In this connection the total current is the sum of the individual battery current and the total voltage is the voltage of one battery. In parallel connection, the total capacity of the battery bank (group of batteries) will be equal to the sum of the capacities of individual batteries.

### Tools and Instruments used for testing & maintenance of battery

The following tools required for battery maintenance

- Pliers (to open nuts & bolts, tie the wires & hold live wires)
- Wire cutter to cut & strip the wire
- Spanner ( To open nut bolts of contacts)
- Cleaning brush ( To clean battery contact terminals)
- Polish paper (To clean the rough contact surface)

The following are the commonly used instruments for battery testing

- Battery Hydrometer (For measuring the specific gravity of electrolyte)

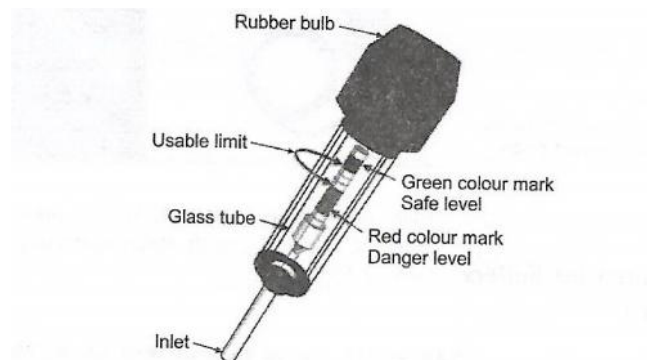

- Battery Tester & multimeter (Used for checking the voltage, current & internal resistance)



Battery Tester

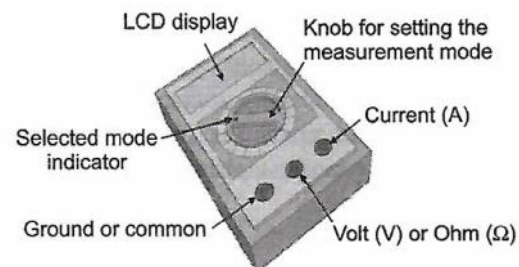

Multimeter

- Clamp meter (Clipping type multi meter to measure voltage, current and resistance not by physical connection but by clamping on the wire connected)

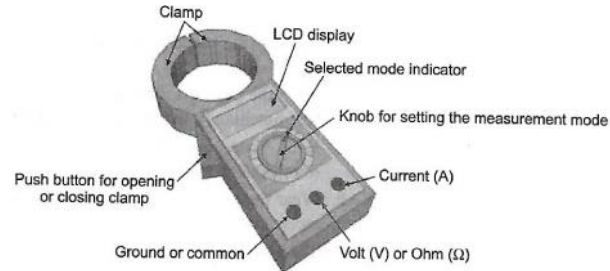

## Types of Lead Acid Batteries

### Tubular Batteries

The tubular battery provides high performance, long life and lower maintenance costs. They are used in batteries for deep discharge cycles. In order to avoid the loss of active materials from electrodes during charging & discharging, tubular electrodes are used.

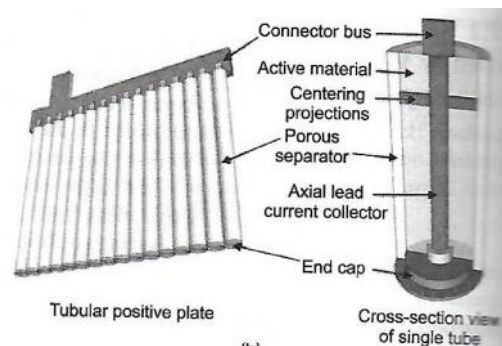

Tubular positive plates are made of 20-30 tubes connected together by a connector bus as shown in the figure

### Unique Design Features and Benefits

Higher energy density than flat plate constructed batteries.

- Greater surface area optimizes active material utilization.
- It resists corrosion which is superior to gravity cast flat plate construction and improves battery life
- Uniform distribution of active material and weight is achieved through a wet filling process which enhances plate uniformity
- Round, non-woven tubular gauntlets provide superior resistance to active material shedding

- Fully enveloped separators reduce the chance of short circuiting
- 1" sediment space to prevent short circuits

### **Valve -regulated Lead-Acid Batteries (VRL Batteries)**

Valve-regulated Lead-Acid batteries are more user-friendly than the conventional batteries found in automobiles. Being maintenance free, they are more accepted in home or office. A new rugged case allows them to be shipped inside electronic equipment, where they can provide energy for uninterruptible power supplies.

### **Absorbed Glass Mat (AGM) Battery**

In AGM Battery the fibrous silica glass mat is used to suspend electrolyte. This forms semi solid or gel electrolyte with empty pockets which helps in recombination of gas generated during charging.

### **Gel Battery**

The gel battery is similar to A G M battery, the difference is the use of silica gel instead of fibrous silica gel.

### **Advantages of Lead acid Battery**

- Economical and simple to manufacture.
- Self discharge is lowest compared to all other batteries.
- Capable of discharging at high rates.

### **Disadvantages**

- Energy density is low
- Short life.
- Cannot be stored in discharged condition.
- Environmentally unfriendly due to the presence of lead which is toxic in nature.

### **Nickel-Cadmium battery (Ni Cd Battery)**

The nickel-cadmium battery (Ni-Cd battery or Ni-Cad battery) is the most commonly used alkaline rechargeable battery. It consists of nickel oxide hydroxide and metallic cadmium as electrodes with potassium hydroxide as the electrolyte. Poly vinyl chloride is used as separator. The abbreviation Ni-Cd is derived from the chemical symbols of nickel (Ni) and cadmium (Cd).

Ni-Cd batteries are used in cordless and wireless telephones, emergency lighting, and other applications. With a relatively low internal resistance, they can supply high surge currents. This makes them a favourable choice for remote-controlled electric model airplanes, boats, and cars, as well as cordless power tools and camera flash units.

Larger flooded cells are used for aircraft starting batteries, electric vehicles, and standby power.

### Advantages

- It facilitates fast charging and has a longer life.
- It allows charging at low temperatures.
- It is the most rugged battery that can withstand both electrical and mechanical abuse and it is normally used for heavy duty industrial applications.

### Disadvantages

- Low energy density.
- Memory effect and not eco friendly due to the use of Cadmium.

## Lithium ion Battery

A lithium-ion Battery is also a secondary storage battery. Lithium ions move from the negative electrode (cathode) to the positive electrode of Li-ion cell during discharge and back when charging. Li-ion batteries use an intercalated lithium compound as one electrode material.

### USES

- Portable devices: these include mobile phones and smart phones, laptops and tablets, digital cameras and camcorders and torches (flashlights).
- Power tools: Li-ion batteries are used in tools such as cordless drills, sanders, saws and a variety of garden equipment.
- Electric vehicles: Because of their light weight, Li-ion batteries are used for propelling a wide range of electric vehicles such as aircraft, electric cars, hybrid vehicles, advanced electric wheel chairs, radio-controlled models, model aircraft and telecommunication applications.

### Battery Bank Installation and Commissioning

The battery bank installation and commissioning is mainly of 2 types

- 1) Replacing old battery bank by new batteries
- 2) Installation and commissioning of complete new battery bank

In the first case all infrastructure for battery installation will be there. But in the second case ensure the availability of infra structures such as battery room, battery charger, Battery stand, cabling from charger to battery and from battery to load. The following steps are involved in the battery bank installation and commissioning.

- For replacement of old battery banks, ensure that the battery bank is isolated from all loads.
- Switch OFF the charger connected to the battery.

- Remove all cables, inter cell/row connectors.
- Place the new batteries on the battery stand. While doing this the polarity of batteries should be confirmed.
- Connect the inter cell connectors and charger to the battery cables & make it ready for initial charging.
- Do the initial charging till cell voltage reaches 2.35 V - 2.45V. Take hourly reading of cell voltage, sp. Gravity and temperature.
- Once the cell voltage reaches 2.35 V - 2.45V reduce charging current to finishing rate and continue charging by keeping the total input Ah rating same.
- While charging the temperature should not exceed 50°C. If it exceeds this value, stop charging allow temperature to come down to 40°C and continue charging.
- After reaching full charge, keep batteries idle for 4 hrs and then discharge the batteries as per specification mentioned (C/10 or C/20) after isolating from the charger.
- Record cell voltage, Sp. Gravity & temperature of all cells. Make sure that no cell over discharged. Then recharge again and again note down all the parameters. If sp. Gravity of any cell falls below standard value, then adjust the Sp. gravity by adding conc.  $H_2SO_4$ .
- Again recharge the batteries and keep them on float charging.

### TE Sample Questions

- 1) During the routine check up of a lead acid cell, the hydrometer shows a reading of 1.16. Write the colour and material of the electrodes of this cell. (1)
- 2) Classify the following cells as primary and secondary and compare their features  
(Zinc chloride cell, Lithium - ion cell, Nickel - cad, zinc - carbon cell) (3)
- 3) In a lead acid cell 12 plates are arranged in 4 compartments. This battery delivers  
A current of 1.5 ampere for 6 hours. Find
  - a. The capacity of this battery
  - b. Draw the sectional view of this battery so as to get a total voltage of 8 Volts and mark all parts.
  - c. Draw the change in connection of these cells to get a voltage of 2 volts.
 (5)

## Unit - 2

### Electronic Components and Devices

#### Introduction

In the curriculum of EET, Electronic components and devices are divided into 2 parts. The first part comprises passive components, diodes and rectifiers. It is included in the first module. The second part of electronics is included in this third module. This part consists of testing, connections and application of transistor, SCR, TRIAC, DIAC, FET, MOSFET, IGBT, zener diode etc. Digital Electronics is also a part of this unit.

#### Learning Outcomes

After completion of this unit, the learner:

- Identifies the types and connections of transistors
- Realises the use of transistor as an amplifier.
- Realises the concept of SCR and its applications
- Explains the construction, working and application of TRIAC, DIAC, FET-MOSFET & IGBT
- Realises the concept of Zener diode and its use as voltage regulator.
- Realises the applications of LCD, photo diode, photo transistor, LDR
- Realises the concept of inverter and its basic circuit.
- Explains binary and decimal number systems and conversion.
- Comprehends the working of logic gates such as AND, OR, NOT, NAND, NOR & XOR.

#### Concept Detailing

##### Electronic components and devices- II

#### Introduction

In the previous modules we have gone through the basic semiconductor theory and working of PN junction diode as rectifier and familiarized some of the electronic components such as resistors capacitors inductors, LED etc. and practiced the assembling and repairing of LED lamps. In this module more electronic components such as transistors, FET, MOSFET, IGBT, LCD, LDR, Photo diode, Photo transistor etc. are dealt with.



## Bipolar Junction Transistor (B.J.T)

Transistor is a three layer three terminal (emitter, base, collector) device made by sandwiching either a P type or an N type semiconductor in between two opposite semiconductor material. So there are two types of transistors PNP and NPN transistor.

### 1. PNP Transistor

It is formed by sandwiching an N type semiconductor in between two P type semiconductors.

### 2. NPN Transistor

It is formed by sandwiching a P type semiconductor in between two N type semiconductor material. A transistor has three terminals such as emitter, base and collector.

#### Emitter (E)

The majority charge carriers are emitted from this region. Emitter is highly doped to produce enough charge carriers. Emitter is of medium size and the emitter-base junction is always forward biased.

#### Base (B)

Base is similar to controlling terminal. Base is lightly doped and always thin.

#### Collector (C)

Collector accept the charge carriers emitted from the emitter. The collector is the largest section of a transistor and the collector-base junction is always reverse biased. The collector is moderately doped.

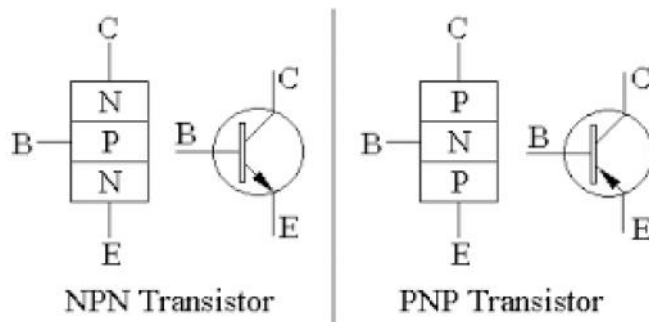
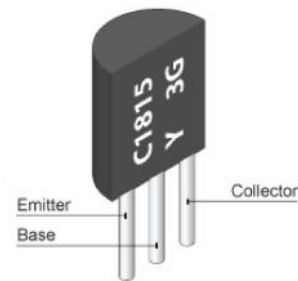

*Collect different electronic components, identify, classify in to active and passive components then make an album.*

### Transistor Biasing

The process of connecting external supply to a PN junction is known as biasing. The manner of connecting the negative battery terminal to the N-type and the positive battery terminal to the P type results in current flow and is called forward biasing. Similarly connecting a negative battery terminal to the P-type material and connecting a positive battery terminal to N-type material is called reverse biasing.

*In transistors, Emitter-Base junction is always forward biased and Collector-Base junction is always reverse biased.*

### Working of a Transistor

The emitter - base junction of the transistor is always forward biased and collector - base junction is reverse biased. Due to the forward biasing, the majority charge carriers are repelled from the emitter section and cross the junction  $J_1$ . Now since the base section is lightly doped and is of smaller in size, most of the charge carriers are attracted towards the collector section due to the reverse biasing. So they cross the junction  $J_2$  and move towards the collector. Due to this movement of charge carriers, conduction takes place in the transistor. The direction of current is as shown in figure (current direction is opposite to the movement of electrons.)

From the figure  $I_E = I_B + I_C$

But  $I_b$  is very much small compared with  $I_E$  and  $I_C$ .

### Working of NPN transistor    Working of PNP transistor

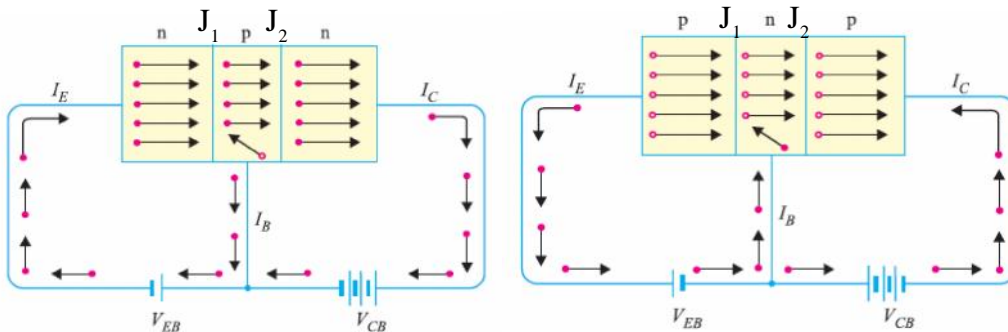

### Transistor configuration or connection

A transistor has only three terminals. But we need four terminals (two input terminals and two output terminals) for connection. So, while connecting in circuits, any one of the three transistor terminals is taken as common. Accordingly there are three types of transistor configuration

1. Common Emitter (CE) configuration
2. Common Base (CB) configuration
3. Common Collector (CC) configuration

### 1. Common Emitter configuration (CEC)

If the emitter terminal is taken as common, it is common emitter configuration. Here input signal is applied across emitter-base junction and output is taken across the emitter and collector terminal. It is the most commonly used configuration in Amplifier Circuits.

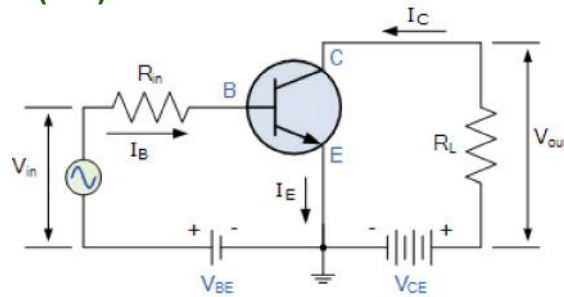

### Common Emitter Amplifier

Amplifier is an electronic device which amplifies a weak signal without any change in the frequency. Common Emitter (C.E) configuration is commonly used because it produces high power gain.

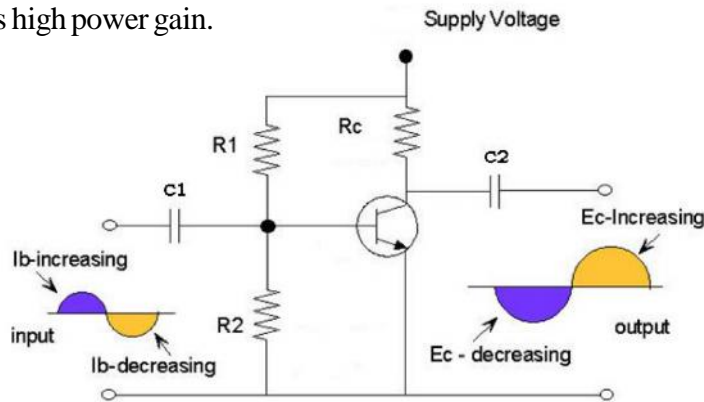

### Working

$R_1$  and  $R_2$  bias the transistor so that a steady collector current flows.  $R_C$  is the load resistor. Signal is applied to the base through coupling capacitor  $C_1$ . During the first half cycle it is positive, and increases the forward bias on the base of the transistor. This increases the base current and thereby the collector current through the load resistor. Therefore the collector voltage, with respect to the zero line, decreases. During the second half cycle, the input signal goes negative, reducing the forward bias on the base. This reduces both base and collector currents. The voltage across the load resistor falls and the voltage on the collector rise. Again, the collector voltage has done the opposite of the base voltage. The transistor inverts the input signal as well as amplifying it. (Phase reversal of  $180^\circ$  is produced)

### Common Base Configuration (CBC)

If the base terminal is taken as common, it is common base configuration. Here input is applied across the emitter-base junction and output is taken across the base and collector terminal as shown in figure.

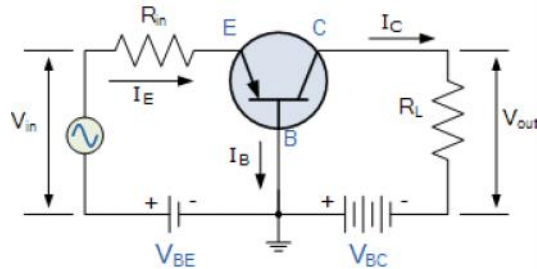

### Common Collector Configuration (CCC)

If the collector terminal is taken as common, it is common collector configuration. Here input signal is applied across base-collector terminal and output is taken across emitter and collector terminals.

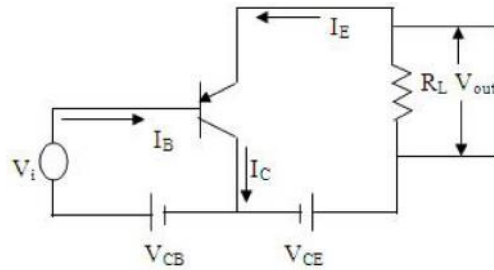

*The input resistance of a bipolar junction transistor (BJT) is always low. It is because its input (emitter-base junction) is always forward biased.*

### Transistor Testing

At first to find whether the transistor is NPN or PNP, connect the common terminal (black) to the emitter or collector and the other terminal (red) of the multimeter to the base of the transistor. If a low resistance is observed the transistor is PNP otherwise [high resistance is observed] transistor is NPN

Now to check whether the transistor is faulty or not, connect the black terminal of the multimeter to P section and red terminal to the N section, check whether the resistance is low. Now reverse the connection and check the resistance is high. Now repeat the process at other junction too. If we can observe a low resistance in the forward bias and high resistance in the reverse bias the transistor is functioning. If not it is faulty.

### To identify the leads of the transistor

Take a pair of leads. Connect the multimeter terminal to it. Note the resistance. Now reverse the connection and again note the resistance. Repeat this process in the other two pairs. The pairs which show high resistance in both directions will be emitter and collector. So the other terminal is base. If a lead is connected to the body of the transistor it is the collector.

## Field Effect Transistors (FET)

The transistors that have studied up to this point are called bipolar junction transistors (BJT). They are two junction devices whose operation depends on the action of two types of charge carriers, holes and electrons. There is another class called field effect transistors (FETs). These are unipolar devices because their action depends on only one type of charge carrier.

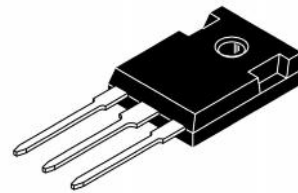

The FET is a three terminal device containing one basic PN junction and can be built as a junction FET (JFET). The three terminals of the FET are called the Source, the Gate and the Drain. There are two types of JFET namely P- channel JFET and N-channel JFET. The N-channel JFET is constructed using a bar of N type material in to which a pair of P- type regions are diffused. The P- type material, called the Gate, which is embedded on both sides of the channel forms a semiconductor junction hence the name junction FET.

### Symbol & Construction of JFET

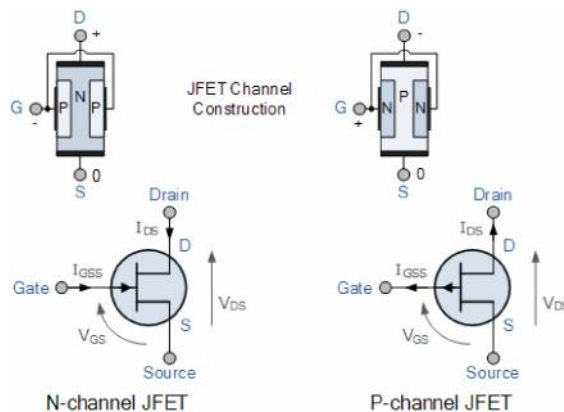

### Comparison between FET and BJT

BJT	FET
It is a current controlled device.	It is a voltage controlled device.
BJT has low input resistance.	It has high input resistance.
It is a bipolar device.	It is a unipolar device.
Its cost is low.	Its cost is high.

### Metal oxide semiconductor field effect transistor (MOSFET)

The MOSFET (Metal Oxide Semiconductor Field Effect Transistor) is a semiconductor device which is widely used for switching and amplifying electronic signals in the electronic devices. The MOSFET works by electronically varying the

width of a channel along which charge carriers flow (electrons or holes). The charge carriers enter the channel at source and exit via the drain. The width of the channel is controlled by the voltage on an electrode called gate which is located between source and drain. It is insulated from the channel by an extremely thin layer of metal oxide such as  $\text{SiO}_2$ .



*The main advantage of MOSFET over a regular transistor is that it requires very little current to turn on (less than 1mA), while delivering a much higher current to a load (10 to 50 times or more).*

Like the JFET the MOSFET is a field effect transistor whose drain current  $I_D$  is controlled by the voltage on the gate. The manner in which the MOSFET is constructed determines whether it is P-channel depletion or an enhancement type.

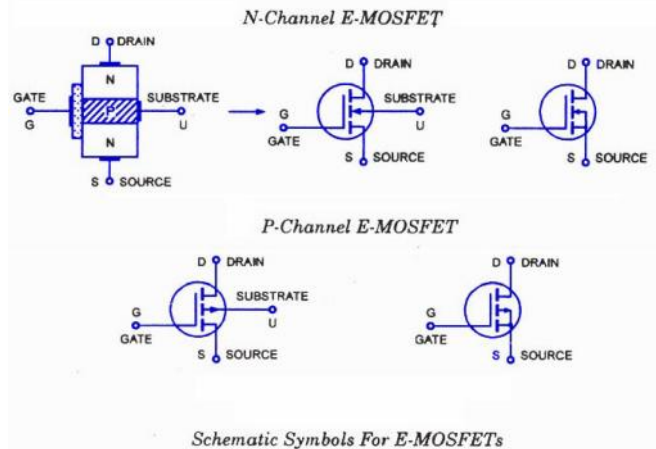

## IGBT

An Insulated Gate Bipolar Transistor (IGBT) is a three-terminal power semiconductor device primarily used as an electronic switch. The three terminals of IGBT are known as 'Emitter', 'Collector' and 'Gate'. It is a type of transistor, which can handle a higher amount of power, and has a higher switching speed making it high efficient. IGBT was introduced to the market in 1980s.

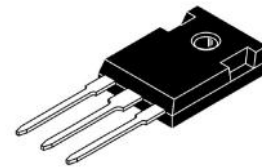

Construction of IGBT

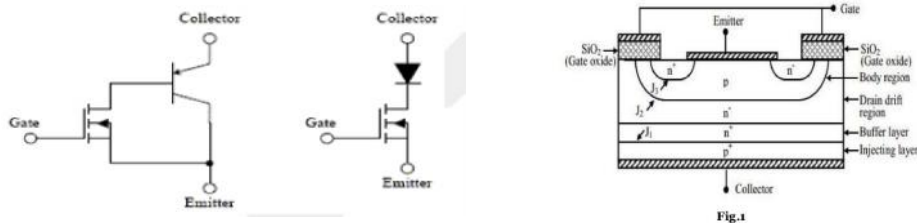

IGBT has the combined features of both MOSFET and bipolar junction transistor (BJT). It is gate driven like MOSFET, and has current voltage characteristics like BJTs. Therefore, it has the advantages of both high current handling capability, and ease of control. IGBT modules (consists of a number of devices) can handle kilowatts of power.

### Applications for IGBTs:

IGBTs are used in high power applications such as:

- Appliance motor drives
- Electric vehicle motor drives
- Power factor correction converters
- Uninterruptible power supplies
- Solar inverters
- High frequency welders
- Inductive heating cookers.

### Difference between IGBT and MOSFET

1. Although both IGBT and MOSFET are voltage controlled devices, IGBT has a BJT like conduction characteristics.
2. Terminals of IGBT are known as emitter, collector, and gate, whereas MOSFET is made of gate, source, and drain.
3. IGBTs are better in power handling than MOSFETS
4. IGBT has PN junctions, and MOSFETs doesn't have them.
5. IGBT has a lower forward voltage drop compared to MOSFET

### Silicon Controlled Rectifier (SCR) or Thyristor

Silicon Controlled Rectifier (SCR) is a four layer three junction, p-n p-n semiconductor switching device. It has three terminals- anode, cathode and gate.

Schematic diagram and circuit symbol for a SCR are shown in fig. The terminal connected to outer P region is called anode (A), the terminal connected to outer N region is called cathode and that connected to inner P region is

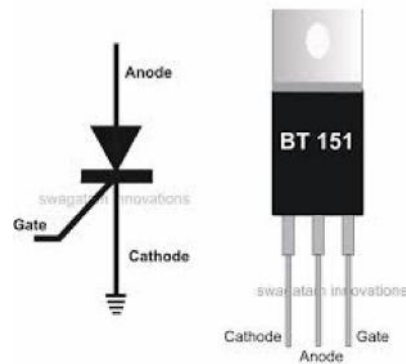

called the gate (G). For large current applications, SCR need better cooling; this is achieved to a great extent by mounting them on to heat sinks.

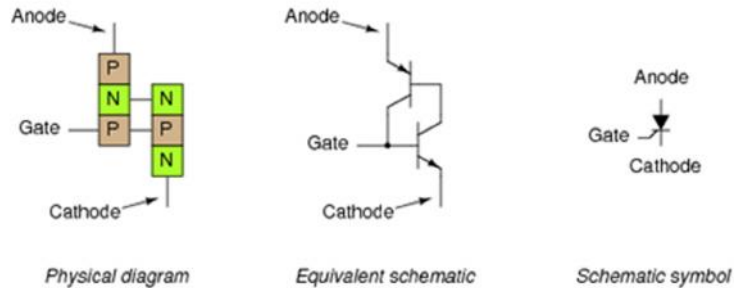

## Application of SCR

### 1. Lamp flasher

SCR is used for lamp flasher application such as DC operated auto mobiles indicators. It is used for remote warning lights in barricades & traffic signals. It is also used for flasher for air craft and advertising signal.

### 2. Electronic circuit breaker

SCR is used in over voltage protection circuit. This type of protection circuit open in few micro seconds compared with that of other milli seconds of conventional electro mechanical circuit breaker.

### 3. SCR motor speed control

SCR is used for motor speed control in houses and shop appliances. This circuit provides constant motor speed under changing load condition as hand drill, mixer etc.

### 4. SCR alarm circuit

SCR is used in alarm circuit where simplicity is required. Typical of such circuits are smoke, heat, water level indicator and power failure signals.

## TRIAC

An SCR is a unidirectional device as it can conduct from anode to cathode only. A TRIAC can however, conduct in both the directions and thus it is a bi-directional SCR with three terminals as in figure below.

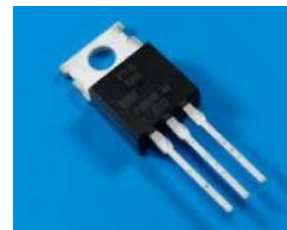
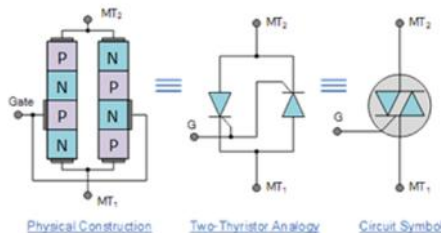



When in operation, a TRIAC is equivalent of two SCRs, connected in anti parallel. TRIAC is used in a.c flashers, fan regulators, time delay circuit, light dimmer control, phase controllers etc. It can conduct in both the directions, so the terminals are named as Main Terminal1 ( $MT_1$ ) and Main Terminal2 ( $MT_2$ ) and Gate (G).

### DIAC

The DIAC is basically a two terminal device which is equivalent to two diodes that are connected in anti-parallel. It is a TRIAC without a gate terminal. A DIAC can be made to conduct in either direction. So it is a bi-directional device.



The switching from OFF to ON state can be achieved by simply exceeding the avalanche breakdown voltage in either direction. The crystal structure of DIAC is basically the same as a transistor with no base connection as shown in figure.

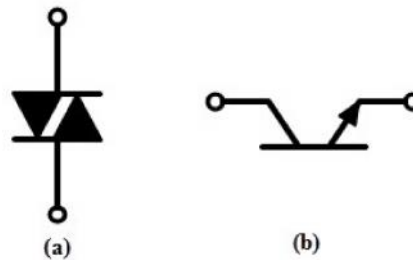

Symbols Used for DIAC

### LCD

The liquid crystal display (LCD) has the distinct advantage of having a lower power requirement than the LED. It is typically in the order of microwatts for the display, as compared to the same orders of milli watts for LEDs. It requires an external or internal light source and the lifetime is limited because of LCD's chemical degradation.

A liquid crystal is materials that flow like a liquid but has the property to align in a definite crystal pattern when energized. It consists of a thin layer (about 10 micro meter) of a liquid crystal sandwiched between two glass sheets with transparent indium oxide electrodes deposited on their inside faces as shown in figure. When not activated the liquid crystal is transparent but when it is energized, the molecular

alignment causes the light to scatter in all directions and hence the activated area appears bright

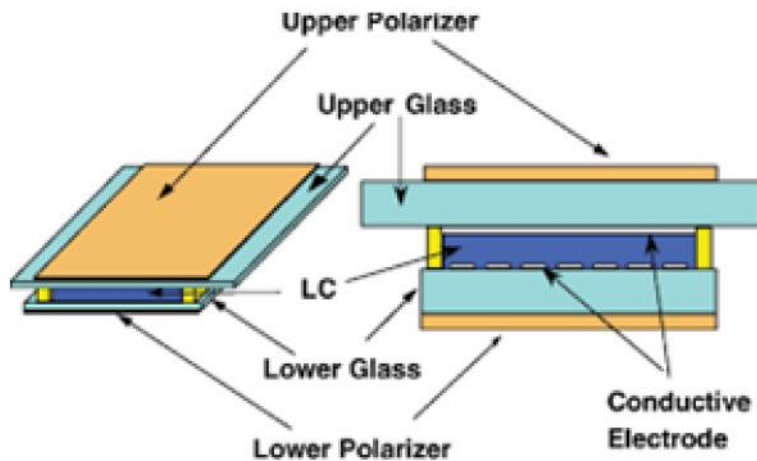

LCD's are used in electronic instrument displays, watches, calculators, counters, television / computer screens etc.

### LDR

A photo resistor (Light-Dependent Resistor, LDR, or photocell) is a light controlled variable resistor. The resistance of a LDR decreases with increasing incident light intensity; in other words, it exhibits photoconductivity. An LDR can be applied in light-sensitive detector circuits, and light and dark-activated switching circuits.

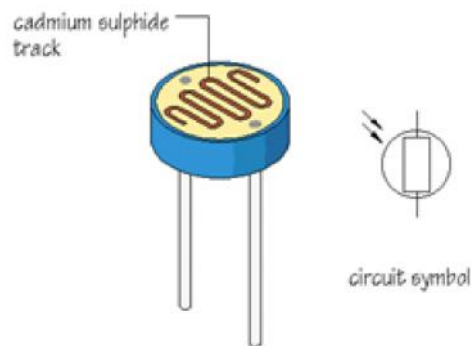

### THERMISTOR

The thermistor is a temperature sensitive resistor; that its terminal resistance is related to its body temperature. It has a negative temperature coefficient of resistance, indicating that its resistance will decrease with an increase in its body temperature. For Ge and

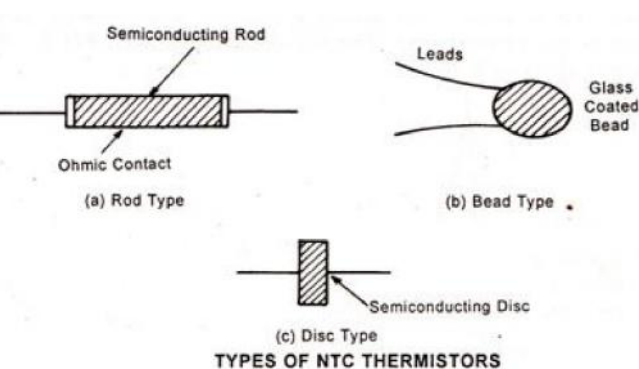

Si, the resistance decreases at the rate of 6 to 8 % per degree Celsius rise in temperature. But Ge and Si are not used as thermistor materials because their properties are too sensitive to impurities. Commercial thermistors are made of oxides of manganese, nickel and cobalt. It consist of semiconductor bead of approximately 0.04 centimeter diameter to thin wires are attached to the head to provide two terminals.

Thermistors are used in electronic circuits as sensors in microwave power measuring equipment, temperature compensators and temperature sensors for electronic thermometers.

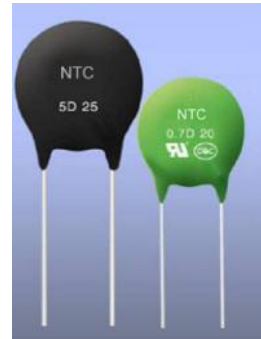
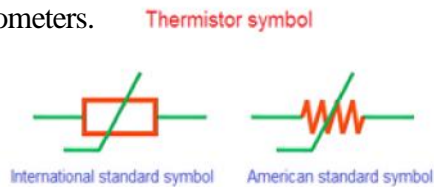

## PHOTODIODE

A photodiode is a semiconductor device that converts light into current. The current is generated when photons are absorbed in the photodiode. A small amount of current is also produced when no light is present. Photodiodes may contain optical filters, built-in lenses, and may have large or small surface areas. Photodiodes usually have a slower response time as their surface area increases. The common, traditional solar cell used to generate electric solar power is a large area photodiode.

### Principle of operation

When a photon of sufficient energy strikes the diode, it creates an electron-hole pair. This mechanism is also known as the inner photoelectric effect. If the absorption occurs in the junction's depletion region, or one diffusion length away from it, these carriers are swept from the junction by the built-in electric field of the depletion region. Thus holes move toward the anode, and electrons toward the cathode, and a photocurrent is produced. The total current through the photodiode is the sum of the dark current (current that is generated in the absence of light) and the photocurrent, so the dark current must be minimized

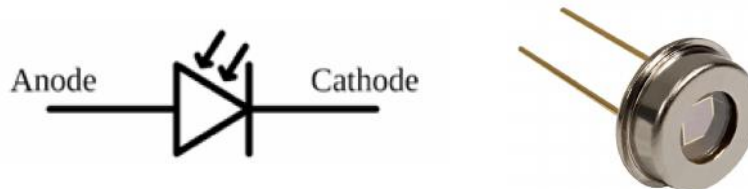

## PHOTOTRANSISTOR

The phototransistor is a semiconductor light sensor formed from a basic transistor with a transparent cover that provides much better sensitivity than a photodiode.

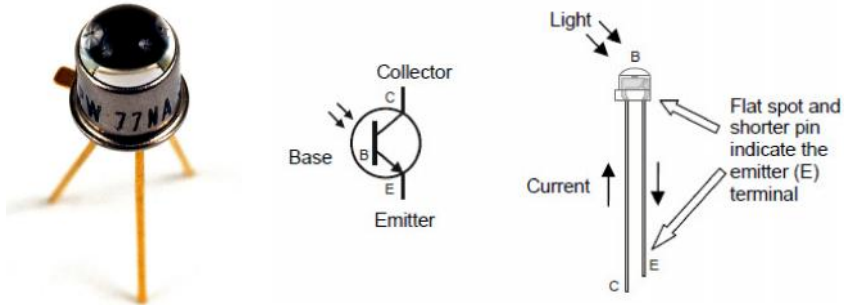

### Phototransistor structure

The photo transistor has much larger base and collector areas than a normal transistor. These devices were generally made using diffusion or ion implantation. Homo-junction structure was used in conventional photo transistors and the material was germanium or silicon. The modern phototransistors are having hetro junction structure using materials such as gallium arsenide.

USES: Photo transistors are used as light sensors in security systems, street light controllers, IR photo detectors, computer logic circuits, relays, punch card readers etc.

## SUPER CAPACITOR

A super capacitor (SC) (sometimes ultra capacitor, formerly electric double-layer capacitor (EDLC)) is a high-capacity electrochemical capacitor with capacitance values much higher than other capacitors (but lower voltage limits) that bridge the gap between electrolytic capacitors and rechargeable batteries. They typically store 10 to 100 times more energy per unit volume or mass than electrolytic capacitors, can accept and deliver charge much faster than batteries, and tolerate many more charge and discharge cycles than rechargeable batteries. They are however 10 times larger than conventional batteries for a given charge.



Super capacitors are used in applications requiring many rapid charge/discharge cycles rather than long term compact energy storage: within cars, buses, trains, cranes and elevators, where they are used for regenerative braking, short-term energy storage or burst-mode power delivery. Smaller units are used as memory backup for static random-access memory (SRAM).

### ZENER DIODE AS VOLTAGE REGULATOR

Zener diode is the most commonly used electronic component as a voltage regulator or stabilizer. The zener diode is reverse connected across the load  $R_L$  through which constant output is desired. Consider the figure above in which a resistor ' $R_s$ ' is connected in series with the zener diode to limit the circuit current as well as to absorb the voltage fluctuations. At the time of conduction the voltage across the zener will be equal to its break down voltage  $V_Z$  and it will maintain a constant voltage across the load as long as the input voltage does not fall below  $V_Z$ . So the output voltage remain constant even when the input voltage changes.

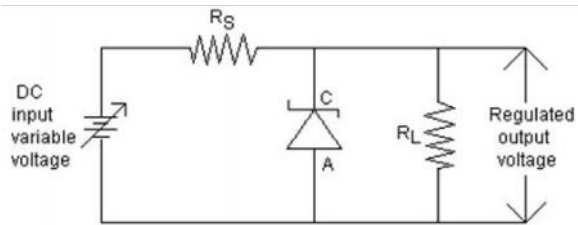

### REGULATED POWER SUPPLY USING 7805 IC

#### Necessity of Voltage Regulator

A rectifier with an appropriate filter serves as a good source of dc output. Major disadvantage of such power supply is that the output voltage changes with the variation of input voltage or load, in order to ensure that output voltage is not changed even if input voltage or load is varied, voltage regulator circuit is used. The last 2 digits in the regulator IC number indicate the output voltage.

#### Regulator IC

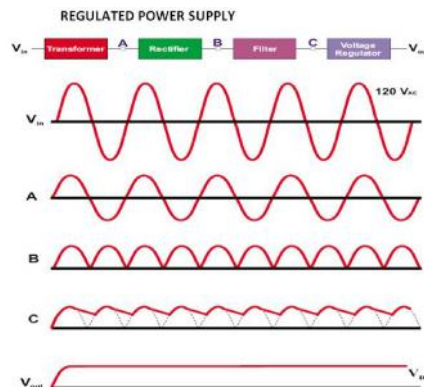
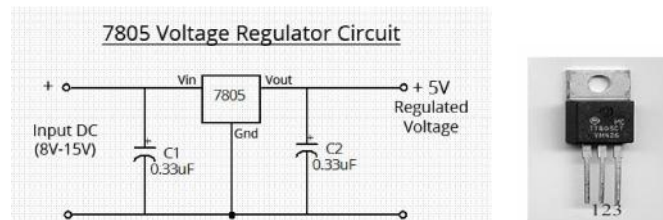

The 78XX series are examples of positive output regulators.  
The 79XX series are examples of negative output regulators.

Type Number	Output Voltage
7805	5 V
7806	6 V
7808	8 V
7809	9 V
7812	12 V
7815	15V
7818	18V
7824	24 V

## INVERTER

Inverters are static circuits (that is, they have no moving parts) that convert DC power into AC power at a desired output voltage, current and frequency. The dc power input to the inverter is obtained from an existing power supply network or by rectifying and filtering the utility source by the diode rectifier circuit or from a battery, photovoltaic cell or fuel cell.

The output voltage waveforms of ideal converter should be sinusoidal. However, the waveforms of practical inverters are non-sinusoidal and contain certain undesirable waveforms called harmonics. Elimination of harmonics may decide the cost of inverter.

Inverters are used now a day in equipment that are used as a power source during the time of main supply failure. Inverters are also used in many industrial applications, including speed control of induction and synchronous motors; aircraft power supplies and high voltage dc transmission.

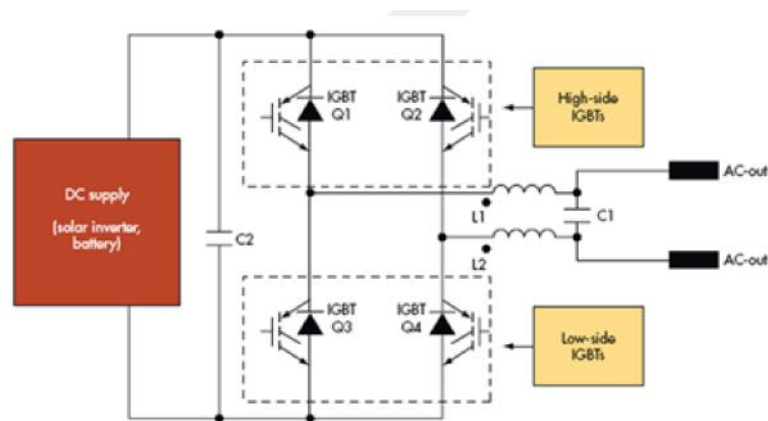

1. The solar-power inverter taps high-voltage IGBTs in a full-bridge topology.

## OSCILLATOR

### Basic Oscillator Circuit ( LC Tank circuit)

Oscillators are used to convert DC into AC

A simple tank circuit consist of a capacitor and an inductor connected in parallel. The frequency of the oscillated wave is determined by the value of L & C.

Initially the capacitor is fully charged by a battery with the help of an SPDT switch. In the other position of the switch the capacitor discharges through the inductor. Once the capacitor is fully discharged, the induced emf in the inductor keeps the current flow in the same direction and hence the capacitor becomes charged again with the opposite polarity. After this the capacitor starts discharging in the opposite direction and the process continues. The output of LC tank circuit is always a damped oscillation. In order to make undamped oscillation COLPIT oscillators & HARTLEY oscillators are used.

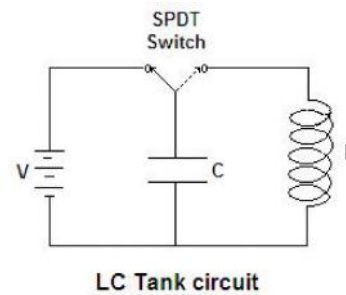

### BLOCK DIAGRAM OF AN OSCILLATOR

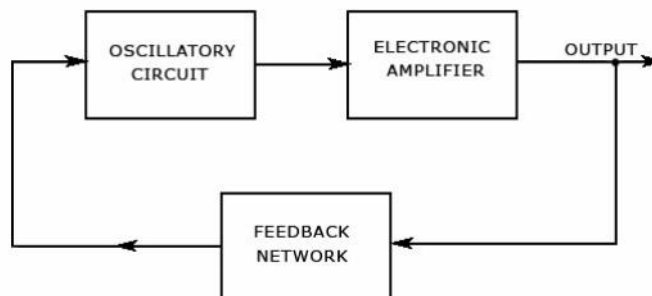

### Damped oscillation

Oscillation whose amplitude goes on decreasing with time is called damped oscillation

### Un damped oscillation

Oscillation whose amplitude remains constant is called un damped oscillation

### Application

emergency lamp, CFL, inverter, electronic choke etc.

### UNINTERRUPTIBLE POWER SUPPLY (UPS)

UPS are used for providing battery backup for computers, telephone exchanges, TV transmission stations, nuclear reactors and other personal productivity electronics.

Uninterruptible power supply mainly comprises of a converter for converting ac to dc, a battery for storing electric charges and an inverter for converting dc into ac. The input is connected to the single phase 230 V AC or 3 phase 415 V AC. When the power is available converter supplies dc power to charge the battery and when power goes battery supplies power through the inverter. The change over switch at position S1 connects this output to load at the time of power failure and connects back to normal mode (switch at S2) when supply resumes. UPS is specified in VA and duration of time the battery operates. Hence for getting more VA and time batteries with higher Ampere-hour are used.

### Block Diagram of UPS

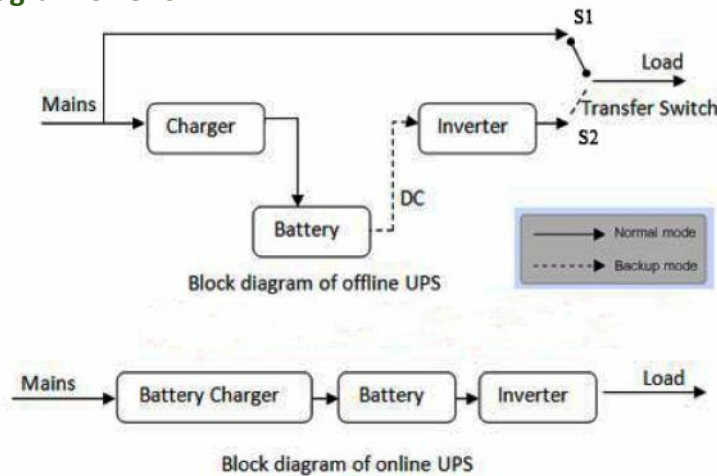

### Digital Electronics

The main difference between analog and digital operation is the way the load line is used. In analog circuits, adjacent points on the load line may be used, so the output voltage is continuous; therefore the output voltage can have an infinite number of values. Analog operation has a sinusoidal input, as the continuously changing input voltage produces a continuously changing output voltage.

Almost all digital circuits are designed for two-state operation that is using only two non adjacent points on the load line. So the output voltage has only two states either low or high. One way to get digital operation is with square wave input.

### Number systems

#### Binary system

The number system which uses 0 and 1 as digits is called Binary number system. Almost all digital computers and systems are based on binary operation. A Binary digit is called a bit.



### Binary to Decimal Conversion

We can convert a binary number in to decimal by giving the position values.

Steps in binary to decimal conversion.

1. Write the binary number.
2. Directly under the binary number write 1,2,4,8, 16, 32,..... Working from right to left.
3. If a zero appears in a digits position , cross out the decimal weight of that position.
4. Add the remaining weights to obtain the decimal equivalent.

Example  $10110011_{(2)}$

Step1	1	0	1	1	0	0	1	1
Step2	128	64	32	16	8	4	2	1
Step3	128	×	32	16	×	2	×	1
Step4	128	+	32	+	16	+	2	+ 1 = 179 <sub>(10)</sub>

For fractions the weights of position to the right of binary point is 0.5, 0.25, 0.125, .....

Add the position values of 1's.

Example  $0.1101_{(2)}$

0.1	1	0	1
0.5	0.25	0.125	0.0625
0.5	+	0.25	+ 0.0625 = 0.8125 <sub>(10)</sub>

For mixed numbers apply the above two methods together

Example  $11001.101_{(2)}$

1	1	0	0	1.	1	0	1
16	8	4	2	1.	0.5	0.25	0.125
16	+	8	+	1	+	0.5	+ 0.125 = 25.625 <sub>(10)</sub>

### Decimal to binary conversion

The popular way of converting decimal numbers to binary is Double Dabble Method.

In this method progressively divide the decimal number by 2, writing down the remainder after each division, until the quotient is zero. The remainders taken in the

reverse order form the binary number.

Example  $26_{(10)}$

2	26	
2	13	0
2	6	1
2	3	0
2	1	1
	0	1

read up       $26_{(10)} = 11010_{(2)}$

### Fractions

For converting fractions multiply by 2 and record the carry in the integer position up to required number of digits. The carries read downwards is the binary fraction.

Example  $0.95_{(10)}$

$0.95 \times 2 = 1.9 = 0.9$	with a carry	1	<div style="display: flex; align-items: center;"> <div style="border-left: 1px solid black; height: 100px; margin-right: 5px;"></div> <div style="writing-mode: vertical-rl; transform: rotate(180deg);">Read down</div> </div>
$0.9 \times 2 = 1.8 = 0.8$	with a carry	1	
$0.8 \times 2 = 1.6 = 0.6$	with a carry	1	
$0.6 \times 2 = 1.2 = 0.2$	with a carry	1	
$0.2 \times 2 = 0.4 = 0.4$	with a carry	0	
$0.4 \times 2 = 0.8 = 0.8$	with a carry	0	
$0.8 \times 2 = 1.6 = 0.6$	with a carry	1	

$0.95_{(10)} = 0.1111001_{(2)}$

### Additional information

1 BINARY DIGIT	BIT	X
4 BITS	NIBBLE	XXXX
8 BITS	BYTE	XXXX XXXX

### LOGIC GATES

Logic gates are the most basic logic circuit, which are the fundamental building blocks from which all other logic circuits and digital system are constructed. The most common logic gates are OR, AND, NOT, NAND, NOR & XOR gates.

#### 1. OR Gates

An OR gate has two or more input signals and only one output. It is called OR gate because the output voltage is high if any or all the inputs are high.

### Symbol & Truth table

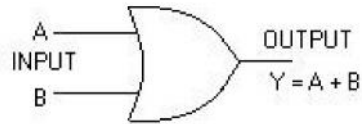

TRUTH TABLE

INPUT		OUTPUT
A	B	$Y = A + B$
0	0	0
0	1	1
1	0	1
1	1	1

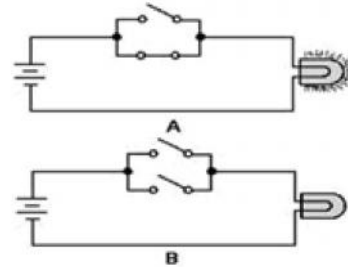

### Diode Equivalent Circuit of OR Gate

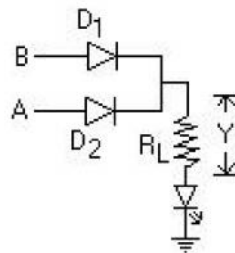

## 2. AND Gates

The AND gate has a high output only when all inputs are high.



TRUTH TABLE

INPUT		OUTPUT
A	B	$Y = A * B$
0	0	0
0	1	0
1	0	0
1	1	1

## 3. NOT gate

The NOT gate performs a basic logic function called inversion or complementation. The purpose of gate is to change one logic level to opposite level. It has one input and one output. It is a single input gate. Its output is always the compliment of the input. Not gate is also called inverter.

## Truth Table Electrical &amp; Diode Equivalent Circuit

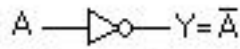

Input	Output
A	$Y = \bar{A}$
0	1
1	0

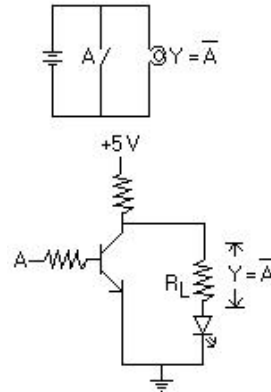

## 4. NAND Gate

NAND is the contraction of NOT-AND. It has two or more inputs and only one output. When all the inputs are high, the output is low. If any of the inputs is low, the output is high. The logic symbol and truth table of NAND gate are shown below.

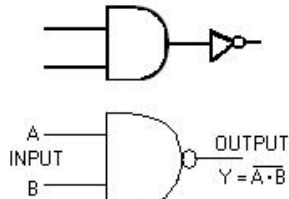

TRUTH TABLE

INPUT		OUTPUT
A	B	$Y = \bar{A} \cdot \bar{B}$
0	0	1
0	1	1
1	0	1
1	1	0

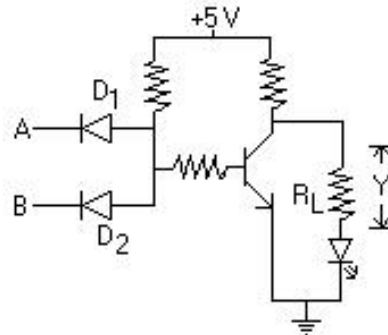

## 5. NOR gate

NOR is the contraction of NOT-OR. It has two or more inputs but only one output. When any of the inputs is high, the output is low. Only when all the inputs are low, the output is high.

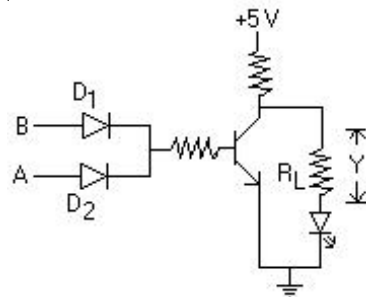

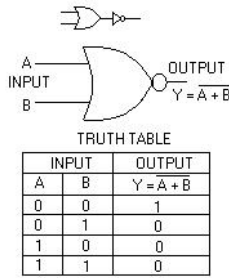

NAND gates are known as basic or universal gates because they can be connected to other NAND gates to generate any logic functions..(The NOR gate is also a universal gate because it can also be connected to other NOR gates to generate any logic functions.)

**NOT Gate using NAND gate**

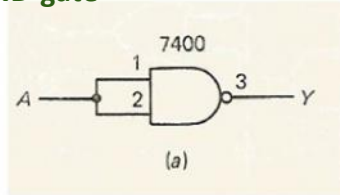

**AND gate using NAND gates**

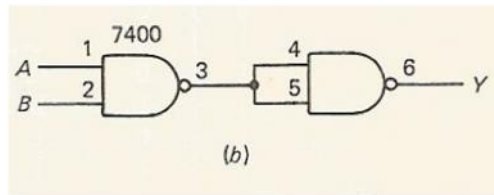

**OR Gate using NAND gates**

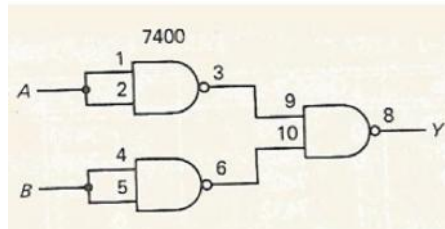

**XOR gate or Exclusive OR Gate**

An exclusive OR (XOR) gate has two or more inputs but only one output. The output of XOR gate is high when odd number of inputs is high.



**Assessment activity**

Set up equivalent circuit of different gates using lamps, verify truth tables

A	B	Output
0	0	0
0	1	1
1	0	1
1	1	0

### Boolean Algebra

In Boolean Algebra, a variable can be either a zero or one. Some of the Boolean laws are given below.

#### Basic laws

$A + B = B + A$	$A \cdot B = B \cdot A$
$A + (B + C) = (A + B) + C$	$A \cdot (B \cdot C) = (A \cdot B) \cdot C$
$A(B + C) = AB + AC$	

#### OR Operation

$A + 0 = A$	$A + A = A$
$A + 1 = 1$	$A + ? = 1$

#### AND Operation

$A \cdot 1 = A$	$A \cdot A = A$
$A \cdot 0 = 0$	$A \cdot ? = 0$

### TE QUESTIONS

1. NOR is inverted OR gate. Substantiate with Truth Table.
2. Name the type of capacitor used in motor circuits. Mention the steps involved in the testing of this capacitor using AC supply.
3. In transistor connection, one terminal is taken as common in both input and output. Write the need for it. Draw all the possible connections of transistors and mark input and output terminals.

## Unit - 3

### Solar PV System Installation and Maintenance

#### Introduction

Solar PV system installation and maintenance is the third unit in the third module. This unit is the most significant one because the skill certificate is related to this area. This unit consists of the importance of solar energy, its harvesting. The construction, features and installation of solar PV modules and some solar devices are also dealt with.

#### Learning Outcomes

- Realise the concept of Solar energy and its advantages and disadvantages.
- Comprehend photovoltaic effect and solar cells.
- Explain the operating principles, types, equivalent circuit of a PN junction solar cell.
- Realise the concept of photovoltaic module and connections of solar cells in series, parallel.
- Realise the concept of rating of PV module and factors affecting power.
- Select solar module according to requirement.
- Realise the concept of I V characteristics of PV module and mismatch in PV module.
- Select batteries for P V module.
- Realise the concept of conversion of solar voltage to fixed DC and AC .
- Identify the concept of charge controller in the circuit.
- Comprehend wire sizing in PV systems and PV system configurations.
- Install solar panel.
- Carryout maintenance of solar panel and solar PV devices.

#### Concept Detailing

##### Solar PV System Installation and Maintenance

##### Introduction To Energy

Energy is a concept which can be described as "the ability of an object to do work". All the objects which have ability to work are said to possess energy. The energy can have many forms like heat energy, electrical energy, sound energy, light energy etc. Electrical energy is one of the most convenient forms of energy. Almost all equipment around us can work on electrical energy. The conversion and use of solar energy into electrical energy is the topic of this unit.

The energy sources can be divided into two broad categories as renewable and non-renewable energy sources. Both of them are derive from the nature, but they are different from the perspective of availability.

### Non Renewable Energy Sources

The natural energy source such as coal, petroleum, oil and natural gas take thousands of years to form naturally. i.e, their rate of production is low. These fuels cannot be produced as fast as they are consumed which will result in their depletion with prolonged usage. Thus, due to limited availability, the fossil fuels are considered non-renewable energy sources.

### Renewable Energy Sources

They are natural energy sources which are continuously produced by natural processes. This includes solar radiation, wind, bio-mass, hydro etc. This energy sources can be harnessed in any amount and cannot be depleted as they are self-replenished by the nature itself.

### Energy situation in Kerala

Kerala is blessed with huge hydro power potential by way of plentiful rain and many rivers. However, out of the estimated hydal potential of about 6000 MW, only about 2040 MW have been harnessed so far in the state due to denial of environmental and forest clearances. On the basis of state wise installed capacity, Kerala stands at 16th position with approx. 1.66% of total installed capacity in the country. Kerala State Electricity Board Limited (KSEBL) is the single power entity looking after generation, transmission & distribution of electricity in the State.

*Note: 1 unit of electricity = 1000 WH or 1KWH.*

*People get their electricity bill based on the number of electricity units they consume bimonthly. The government declares the cost of electricity or 1 KWH or 1 unit of electricity. The present rate varies between Rs2-8 per KWH depending on the sector (domestic or commercial).*

Power Sector in Kerala plays a vital role in all developmental activities in Kerala. Obviously power crisis is the Prime obstacle to start new initiatives in the industrial field. The need for power is increasing and the production of power should also increase accordingly. Monsoon is essential to sustain the hydropower base in the state and the shortage in rainfall usually creates power crisis. KSEB has entered into Power Purchase Agreements (PPAs) with various Central Generating Stations of NTPC, NLC, NPCIL etc. As a measure to encourage non-conventional sources of energy, KSEB has executed 38 PPAs for purchase of power from wind energy projects and from two Small Hydro Projects, namely, Meenvallom and Iruttikkanam. ANERT was entrusted with the programmes for renewable energy studies and development programmes in the State. ANERT is also functioning as the State Nodal Agency (SNA) of the central Ministry of New Renewable Energy (MNRE). Now a days being a cheap and clean renewable energy source, solar energy harvesting is promoted by KSEB & ANERT.



## SOLAR ENERGY

Solar energy is the renewable energy of light and heat (i.e. radiation from the sun.) This energy is harnessed using a range of ever-evolving technologies.

### Advantages

- It is clean and non-polluting
- It is a renewable energy
- Solar cells do not produce noise and they are totally silent.
- Solar energy can be used in remote areas where it is too expensive to extend the electricity power grid.
- They require very little maintenance.
- They are long lasting sources of energy which can be used almost anywhere
- They have long life time.
- There are no fuel costs or fuel supply problems.

### Disadvantages

- Solar energy can only be harnessed when it is daytime and sunny.
- Solar collectors, panels and cells are relatively expensive to manufacture although prices are falling rapidly.
- Solar power stations can be built but they do not match the power output of similar sized conventional power stations. They are also very expensive.
- In countries where the unreliable climate means that solar energy is also unreliable as a source of energy. Cloudy skies reduce its effectiveness.
- Large areas of land are required to capture the sun's energy. Collectors are usually arranged together especially when electricity is to be produced and used in the same location.
- Solar power is used to charge batteries so that solar powered devices can be used at night. However, the batteries are large and heavy and need storage space. They also need replacing from time to time.

### Photovoltaic Effect and Solar Cell

The "photovoltaic effect" is the basic physical process through which a solar cell converts sunlight into electricity. Edmund Becquerel, a French experimental physicist, discovered the photovoltaic effect in 1839.

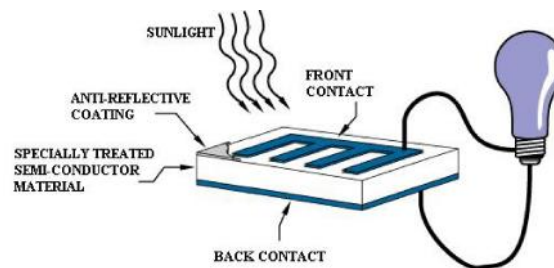

### Operation of a Basic Photovoltaic Cell

A solar cell, or photovoltaic cell, is an electrical device that converts the energy of light directly into electricity by the photovoltaic effect. Input to solar cells is energy in the form of solar radiation and output from the solar cells is energy in the form of electricity.

The electricity generated by a single solar cell is very small, therefore, in order to generate more electricity, many solar cells are connected together to form a PV module. The number of solar cells to be connected together and the way in which they are connected together, is determined by the current and voltage requirement.

#### *Number of Solar Cells in a Module*

*The PV modules are usually designed for charging 12 V batteries. The voltage required for charging these batteries can be obtained by series connection of 36 Silicon based solar cells.*

### Construction

Solar cells are made using different types of materials. A solar cell technology gets its name from the type of material used for solar cell fabrication. The types of materials include mono-crystalline silicon, multi-crystalline silicon, amorphous silicon, cadmium telluride etc.

Most modern solar cells are made from either crystalline silicon or thin-film semiconductor material. Silicon cells are more efficient at converting sunlight to electricity, but generally have higher manufacturing costs. Thin-film materials typically have lower efficiencies, but can be simpler and less costly to manufacture. A specialized category of solar cells - called multi-junction or tandem cells - are used in applications requiring very low weight and very high efficiencies, such as satellites and military applications. All types of PV systems are widely used today in a variety of applications.

Multi-junction (MJ) solar cells are solar cells with multiple p-n junctions made of different semiconductor materials. The majority of multi-junction cells have three layers made of Germanium for the bottom-, GaAs for the middle-, and GaInP<sub>2</sub> for the top-cell. Each material's p-n junction will produce electric current in response to different wavelengths of light. The use of multiple semiconducting materials allows the absorbance of a broader range of wavelengths, improving the cell's efficiency.

### Solar Cells, Modules and Array

Photovoltaic cells are connected electrically in series and/or parallel circuits to produce higher voltages, currents and power levels. Photovoltaic modules consist of PV cell circuits sealed in an environmentally protective laminate, and are the fundamental

building blocks of PV systems. Photovoltaic panels include one or more PV modules assembled as a pre-wired, field-installable unit. A photovoltaic array is the complete power-generating unit, consisting of any number of PV modules and panels.

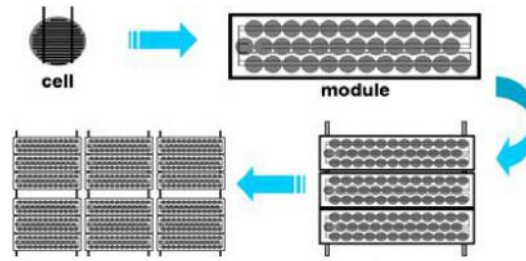

### Series and Parallel Connection of Cells

Series connection is done in order to increase the output voltage, while parallel connection is done in order to increase the output current. While making series and parallel connection of cells, it is assumed that all cells have the same characteristic, i.e., they are identical in all aspects.

In order to connect cells in series, positive terminal of one cell should be connected to the negative terminal of the next cell. In Si solar cells the side which looks bluish is generally a negative terminal of the next cell. When two cells are connected in parallel the current from the two cells will be added while the voltage of the combination will remain the same as that of a single cell.

### Fabrication of PV Module

In a PV module, the cells are connected in series/parallel to give appropriate current and voltage requirement. In order to ensure long life of these cells, they are required to be protected from the environmental conditions. Moisture in the environment can erode the metal contacts and affect the anti-reflective coating on the cells. The cells should also be protected from dust, rain, mechanical shock etc. Hence in order to protect from environmental damage, PV Modules are packaged using glass (low iron content, toughened and textured glass) at the front side and a hard polymer material (Poly Vinyl Fluoride - PVF) at the rear side of the module. It is also protected by using two sheets of encapsulant (Ethylene Vinyl Acetate- EVA) at either side of the electrically connected solar cells. The sheets of glass, encapsulant, electrically connected cells and PVF/Tedlar are arranged together and are placed in a machine called laminator. This process can provide hermetically sealed PV modules that can operate in outside condition upto 20-30 years without environmental degradation.

### Mismatch in Cell/Module

In a larger PV array, individual PV modules are connected in both series and parallel. A series-connected set of solar cells or modules is called a "string". The combination of series and parallel connections may lead to several problems in PV arrays. One potential problem arises from an open-circuit in one of the series strings. The current from the parallel connected string (often called a "block") will then have a lower current than the remaining blocks in the module. This is electrically identical to the

case of one shaded solar cell in series with several good cells, and the power from the entire block of solar cells is lost. Bypass diodes may be incorporated or used externally, to maximize the output of module sections still illuminated. The bypass diodes should be chosen in such a way that they have high current carrying capacity and must be identical to avoid mismatch of diodes which cause thermal runaway.

In solar PV modules and PV arrays, several cell modules are connected in series and parallel in order to achieve higher power output. In such situations all devices are required to be identical in terms of electrical parameters. But, usually, there are always some differences, due to the following:

- Difference in cell processing
- Cells or modules of the same rating but different manufacturer
- Different outside conditions, partial shading of cells or modules
- Cell encapsulating material becoming semi-transparent from being transparent due to the damage caused by UV light and
- Breaking of glass cover etc.

*In the night, when modules are not producing power, they can become load for batteries, i.e., current will flow in reverse direction. In order to avoid this, blocking diodes are used.*

## Shading and Hot Spots

### Shading

Shading of a single cell is a problem in PV module because shading just one cell in the module can reduce the power output to zero. The output of the cell declines when shaded by a tree branch, building or module dust. The decline proportionally to the amount of shading. The cell in a module are connected in series. The shading a single cell causes the current in string of cell to fall to the level of the shaded cell. Parallel shading is also reduce the efficiency of the PV module.

### Hot Spots

In PV module there are more cells connected in series. When one cell in this array is shaded, it will become reverse biased. The strong reverse bias may force the shaded cell to break down. This could permanently damage the cell. Even if it is not damaged, it generates a lot of heat. This results in the heating of the shaded cell and nearby area causing 'hot spots' in the module. The 'hot spots' may cause breaking of the glass cover, cell or permanent damage to the module. It is not only shading but the mismatch in the cell's electrical parameters can also cause the 'hot spots' in the module.

*Bypass diode is used to avoid the destructive effect of 'hot spots' in series connected cells. It is connected in parallel with solar cells with opposite polarity to that of a solar cell.*

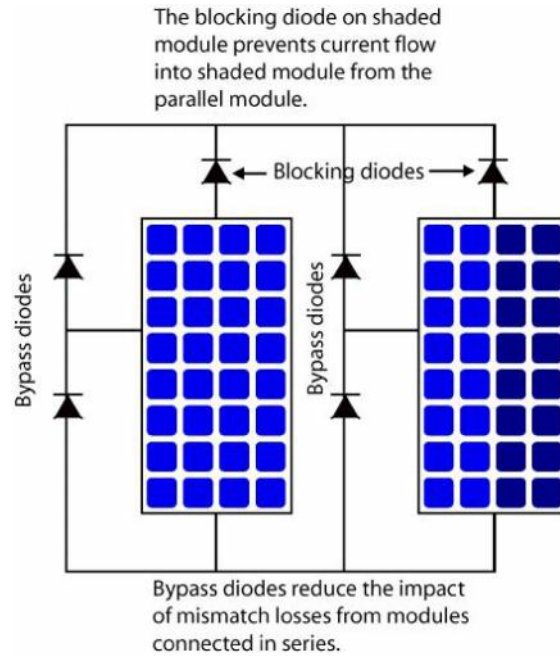

### Rating of PV Module and factors affecting power

The solar PV modules are rated in terms of their peak power output ( $W_p$ ). It is specified by the manufacturer under standard test conditions (STC). The module rating under STC conditions refers to the following:

- Irradiation :  $1000\text{w/m}^2$ .
- Cell/Module temperature: 25 degree centigrade. ( $77^\circ\text{C}$ )
- Wind speed : 1m/s.

The conditions specified in STC do not occur in most of the time or locations. Because of two reasons:

- I. The real solar irradiation is normally less than  $1000\text{w/m}^2$
- II. The module temperature is more than 25 degree centigrade.

This results in lower module power output than expected. In order to have more realistic power output from a PV module, the performance of modules are described in other two test conditions namely standard operating conditions (SOC) and nominal operation conditions (NOC). Both of these use a different concept of temperature called nominal operating cell temperature (NOCT). The NOCT is defined as the temperature reached by a cell in an open circuited module under the following conditions.

- Irradiation :800w/m<sup>2</sup>.
- Ambient temperature: 20 degree centigrade.
- Wind speed : 1m/s.
- Mounting: Open backside.

### Factors affecting Power

- I. Operating Temperature.
- II. Shading.
- III. Latitude of installation (The angle at which day light falls)
- IV. Size of PV array (Solar cell Area)
- V. Charge controller and Solar cell's IV characteristics.
- VI. Inverter Efficiency.
- VII. Cable Thickness
- VIII. Battery Efficiency.
- IX. Conversion efficiency of PV Modules
- X. The amount of sun light.

*When the operating temperature of PV Module increases, the voltage output decreases and reduces the module efficiency. Light falling perpendicular to module gives maximum output power. When the cell area increases, the output power also increases.*

### Solar PV system sizing as per requirement

#### 1. Determine power consumption demands

- 1.1 The first step in designing a solar PV system is to find out the total power and energy consumption of all loads that need to be supplied by the solar PV system as follows:
- 1.2 Calculate the total watt-hours / day of connected load. Multiply this with 1.3 (the energy lost in the system) to get the total Watt-hours per day which must be provided by the panels.

#### 2. Size the PV modules

Different size of PV modules will produce different amount of power. To find out the sizing of PV module, the total peak watt produced needs. The peak watt (Wp) produced depends on size of the PV module and climate of site location. We have

to consider "panel generation factor" which is different in each site location. the panel generation factor is 3.43. To determine the sizing of PV modules, calculate as follows:

#### 2.1 Calculate the total Watt-peak rating needed for PV modules

Divide the total Watt-hours per day needed from the PV modules (from item 1.2) by 3.43 to get the total Watt-peak rating needed for the PV panels needed to operate the appliances.

#### 2.2 Calculate the number of PV panels for the system

Divide the answer obtained in item 2.1 by the rated output Watt-peak of the PV modules available. Increase any fractional part of result to the next highest full number and that will be the number of PV modules required.

Result of the calculation is the minimum number of PV panels. If more PV modules are installed, the system will perform better and battery life will be improved. If fewer PV modules are used, the system may not work at all during cloudy periods and battery life will be shortened.

### 3. Inverter sizing

An inverter is used in the system where AC power output is needed. The input rating of the inverter should never be lower than the total watt of appliances. The inverter must have the same nominal voltage as the battery.

For stand-alone systems, the inverter must be large enough to handle the total amount of Watts that will be using at one time. The inverter size should be 25-30% bigger than total Watts of appliances. In case of appliance type is motor or compressor then inverter size should be minimum 3 times the capacity of those appliances and must be added to the inverter capacity to handle surge current during starting.

For grid tie systems or grid connected systems, the input rating of the inverter should be same as PV array rating to allow for safe and efficient operation.

### 4. Battery sizing

The battery type recommended for using in solar PV system is deep cycle battery. Deep cycle battery is specifically designed for to be discharged to low energy level and rapid recharged or cycle charged and discharged day after day for years. The battery should be large enough to store sufficient energy to operate the appliances at night and cloudy days. To find out the size of battery, calculate as follows:

#### 4.1 Calculate total Watt-hours per day used by appliances.

- 4.2 Divide the total Watt-hours per day used by 0.85 for battery loss.
- 4.3 Divide the answer obtained in item 4.2 by 0.6 for depth of discharge.
- 4.4 Divide the answer obtained in item 4.3 by the nominal battery voltage.
- 4.5 Multiply the answer obtained in item 4.4 with days of autonomy (the number of days that you need the system to operate when there is no power produced by PV panels) to get the required Ampere-hour capacity of deep battery.

$$\text{Battery Capacity (Ah)} = \frac{\text{Total Watt-hours per day used by appliances} \times \text{Days of autonomy}}{(0.85 \times 0.6 \times \text{nominal battery voltage})}$$

### 5. Solar charge controller sizing

The solar charge controller is typically rated against Amperage and Voltage capacities. Select the solar charge controller to match the voltage of PV array and batteries and then identify which type of solar charge controller is right for your application. Make sure that solar charge controller has enough capacity to handle the current from PV array.

For the series charge controller type, the sizing of controller depends on the total PV input current which is delivered to the controller and also depends on PV panel configuration (series or parallel configuration).

According to standard practice, the sizing of solar charge controller is to take the short circuit current ( $I_{sc}$ ) of the PV array, and multiply it by 1.3

Solar charge controller rating = Total short circuit current of PV array x 1.3

Remark: For MPPT charge controller sizing will be different.

### I-V Characteristics of Solar PV module

A solar panel consists of individual cells that are large-area semiconductor diodes, constructed so that light can penetrate into the region of the p-n junction. The junction formed between the n-type silicon wafer and the p-type surface layer governs the diode characteristics as well as the photovoltaic effect. Light is absorbed in the silicon, generating both excess holes and electrons. These excess charges can flow through an external circuit to produce power.

The conversion of sun light to electricity depends on several parameters such as

- Short circuit current ( $I_{sc}$ )- It is the maximum current a solar cell can produce
- Open circuit voltage ( $V_{oc}$ )-It is the maximum voltage that a solar cell can produce.



- Maximum power point ( $P_m$ ) - It is the maximum power that a solar cell produces under S.T.C ( $P_m = I_m \times V_m$ )
- Current at maximum power point ( $I_m$ )
- Voltage at maximum power point ( $V_m$ )
- Fill Factor (FF)
- Efficiency

$$P_m = I_{sc} \times V_{oc} \times FF$$

*The efficiency of a PV Module is defined as the maximum output power ( $P_m$ ) divided by the input power ( $P_{in}$ ). It is expressed as percentage.  $P_{in}$  for STC is considered as  $1000W/m^2$*

The above mentioned parameters can be measured as follows

### Open circuit voltage ( $V_{oc}$ )

While measuring  $V_{oc}$  using a multimeter, connect the two terminals of multimeter across two terminals of the PV module directly. In this arrangement, the reading shown by the meter directly gives the Open Circuit voltage of the PV module. If a negative sign is shown in the meter, it indicates that the polarity of the module terminal is reversed. Hence reverse the connection and measure again.

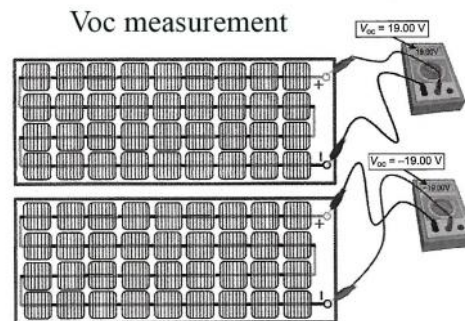

### Short Circuit Current ( $I_{sc}$ )

While measuring the short circuit current of the PV module, ( $I_{sc}$ ), there should not be any load connected to the module. It should be in short circuit condition. Then connect the opposite polarity terminal of multimeter/ammeter and solar PV module directly. The reading shown by multimeter/ammeter in this case is the short circuit current of the given PV module. If a negative sign is shown in the meter with some reading, it indicates that the appropriate polarity of the module terminal and the meter terminal is not connected. Reverse the connection and then measure again.

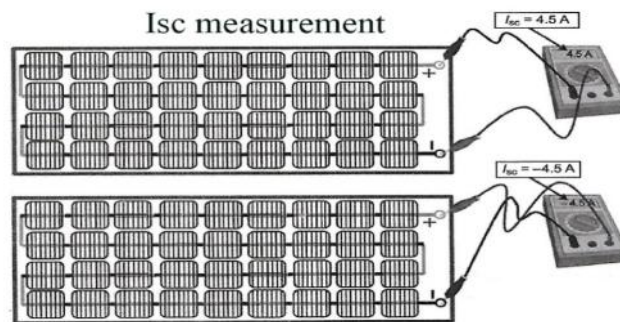

### I-V CHARACTERISTICS

The I-V Characteristics of a Solar PV Module is a graph plotted with the current on 'Y' axis and voltage on 'X' axis. The maximum current a solar PV Module can produce happen when its 2 terminals get shorted, hence the name short circuit current ( $I_{sc}$ ).

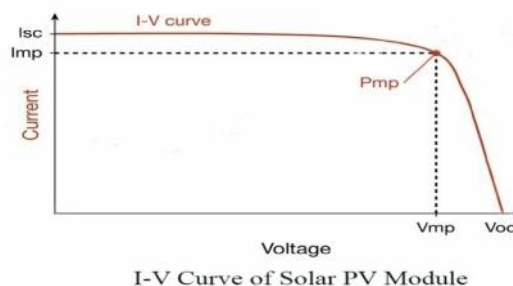

The maximum voltage a solar PV Module can produce happens when its 2 terminals are left open, hence the name Open circuit Voltage ( $V_{oc}$ ).

Normally the maximum power point for I-V Curve occurs at the 'Knee' or 'Bend' of the curve. The voltage and current at the MPP are designated as  $V_m$  and  $I_m$ .

If no load is connected with solar panel which is exposed to sunlight, an open circuit voltage  $V_{oc}$  will be produced but no current flows. If the terminals of the solar panel are shorted together, the short-circuit current ' $I_{sc}$ ' will flow but the output voltage will be zero. In both cases, no power is delivered by the solar panel. When a load is connected, we need to consider the I-V curve of the panel and the I-V curve of the load to figure out how much power can be delivered to the load.

### Practical Work to Plot I-V Curve of a PV Module

#### Objective:

- To plot the I-V Curve of a solar PV Module
- To Determine the optimal conditions for operating a PV panel in a circuit with a known load and understand MPPT (maximum power point tracking);
- To Investigate the effects of solar insolation, shading, and tilting angle on a solar panel through the I-V characteristic measurement.

#### Instruments/Materials Required :

1. DC Ammeter or multimeter (0-10A)
2. DC Voltmeter or a multimeter (0-24 V)
3. Rheostat
4. Connecting Wires
5. Solar PV Module

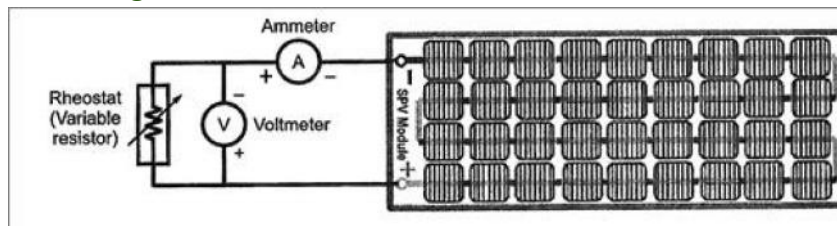
**Circuit Arrangement:****Procedure**

- For measuring the I-V curve, we require two multimeter and a rheostat. Make the electrical connections as shown in figure. For measuring I-V curve, the solar PV module has to be connected in series with the rheostat, i.e., negative terminal of a solar PV module to one end of rheostat and other end of rheostat should be connected to the positive terminal of the multimeter/ammeter. The negative terminal of the multimeter/ammeter should be connected to the positive terminal of the solar PV module. The voltmeter/multimeter for voltage measurement is directly connected across the solar PV module. If any meter show negative reading, then make changes in the connection.
- After making the connections, draw an observation table for noting the current, voltage and power (current x voltage). Then slide the rheostat at one side where the voltage should be maximum and the current should be minimum and note down the values of current and voltage at that instant. Now slightly slide the rheostat, then readings of current and voltage will change. Note down the readings again. Keep on sliding the rheostat and note down the reading until knob of the rheostat reaches the other end.
- Repeat steps in two different sunlight, i.e. different weathers or different time of a day.
- Repeat the steps, and measure I-V curves at different tilting angles of the solar panel. What is the best tilting angle to track the maximum power?
- Repeat the steps & measure I-V curves when shading 1-2 cells of the panel.
- Plot I-V and P-V ( $P = V \times I$ ) curves of the solar panel. Visually estimate  $V_m$ ,  $I_m$ , and  $P_{max}$  (i.e., peak power conditions) from plots. At what load the solar panel will deliver the maximum power ?

**Calculation:**

- Short circuit current ( $I_{sc}$ ) =
- Open circuit voltage ( $V_{oc}$ ) =
- Maximum power point ( $P_m$ ) = ( $P_m = I_m \times V_m$ ) =
- Current at maximum power point ( $I_m$ ) =

- Voltage at maximum power point ( $V_m$ ) =
- Fill Factor (FF) =  $\frac{I_m \times V_m}{I_{sc} \times V_{oc}}$
- Efficiency =  $\frac{I_{sc} \times V_{oc} \times FF}{P_{in} \times A}$

( $P_{in} = 1000\text{w/m}^2$ , A - Area of module in  $\text{m}^2$ .)

### Components of a Solar PV System

The major components of a solar PV system are:

1. PV module: for generating electricity when sunlight falls on it.
2. Battery: for storing electrical energy for night time applications and for time when demand of electricity is more than generated. Batteries are not required in grid connected PV systems.
3. Inverter: for converting DC to AC.
4. Charge controller: for protecting the batteries from overcharge and over discharge.
5. Maximum Power Point Tracker (MPPT) : for extracting maximum available power from solar PV module.

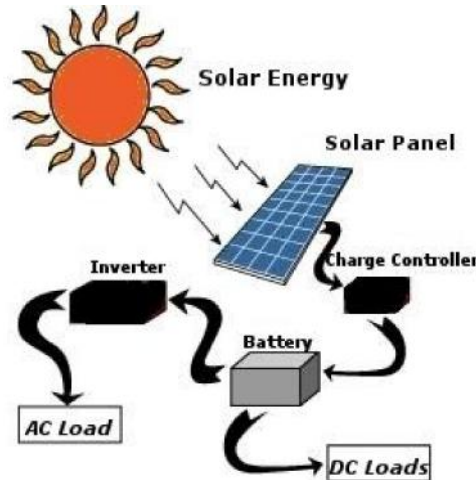

### Charge Controllers

Solar radiation is an unreliable source of energy. It fluctuates as a function of time and is not available during the night or in cloudy sky. Therefore, when the PV systems are used for stand-alone applications, a backup source of energy is necessary to compensate for the balance power demand of the load. Batteries are generally used as a backup source in such applications. To reduce the cost of the system, the ratings of the batteries are designed optimally. Battery feeds the load when the PV output power is less than the load demand and is charged when PV output power is more than the load demand. In applications where batteries are used, it is critical to prevent over charging or deep discharging of the batteries to preserve their life and to ensure good performance. This is achieved by using charge controllers.

### Types of Charge Controllers

- **Shunt type charge controller:** In this type of charge controller, a switch S1 is connected in shunt with the PV panel, which is turned on when the battery voltage reaches its over voltage limit. The blocking diode prevents the short circuiting of the battery. The Switch S2 allows the battery to discharge through the load. When the battery voltage reaches the threshold value, the switch S2 is turned off to prevent deep discharge of the battery.
- **Series type charge controller:** In this type of charge controller, a switch S is connected in series with the PV panel. This switch is turned off to prevent the battery from getting over charged. The major drawback of this method is the additional loss in the switch S.
- **DC to DC converter type charge controller:** A buck, boost or buck boost type DC to DC Converter can be used to regulate the output of the PV Array to feed the load. This type of charge controllers avoid the losses due to the conduction of switches and optimizes the use of the PV source.
- **MPPT charge controllers:** Here, to charge the battery in a more efficient manner, the PV array is operated at a point where the PV output power is maximum. The output power of the PV array changes with the change in voltage across it. To extract maximum power from the PV array, DC to DC converter is used between the PV array and the battery.

### DC TO DC CONVERTERS

DC to DC converters are used for converting one level of DC voltage (usually raw, unregulated) to another level of DC voltage (regulated). This transformation is realized with the help of a network consisting of storage elements like inductor and capacitor and power devices like transistors and diodes. These converters play a vital role in the PV systems where they are used as charge controllers, maximum power point trackers and for interfacing the PV source with different types of loads. The DC to DC circuits are also used for noise isolation, power bus regulation and current boosting.

In DC to DC converters, the output voltage can be either higher or lower or both (higher or lower) as compared to the input voltage. Three basic, second order DC to DC converter topologies exist:

- Buck type DC to DC converter (it steps down the input voltage)
- Boost type DC to DC converter (it steps up the input voltage)

- Buck boost type DC to DC converter (both the step-down and step-up are possible)

In order to change the DC voltage from one level to another, the DC to DC converter uses two electronic switches (one diode and one transistor) and one inductor.

### DC to AC Converter (Inverter)

Solar PV generates Direct Current electricity (DC). A DC to AC converter is used to convert the DC power into AC power because most of the equipment is working in AC supply. Mainly inverters are broadly classified as single phase Inverter and 3 phase Inverter. According to the mode of operation, there are two types of inverters:

- Voltage Source Inverter (VSI) and
- Current Source Inverter (CSI)

### Maximum Power Point Tracker (MPPT)

When a solar PV module is used in a system, its operating point is decided by the load to which it is connected. Since solar radiation falling on a PV module varies throughout the day, the operating point of the module also changes throughout the day. In order to ensure the operation of PV modules for maximum power transfer, a special method called maximum power point tracking (MPPT) is employed in PV systems. In the case of MPPT, electronic circuitry is used to ensure that maximum amount of generated power is transferred to the load. It uses an algorithm and an electronic circuitry. The power from the solar module is calculated by measuring the voltage and current. This power is an input to the algorithm which adjusts the duty cycle of the switch resulting in the adjustment of the reflected load impedance according to the power output of the PV module.

### Classification of PV Systems

- Standalone PV system (A standalone system is the one which is not connected to the power grid.). Here is the only source of power is from solar PV modules. This type of PV system is used when the load is operated during the day time only.

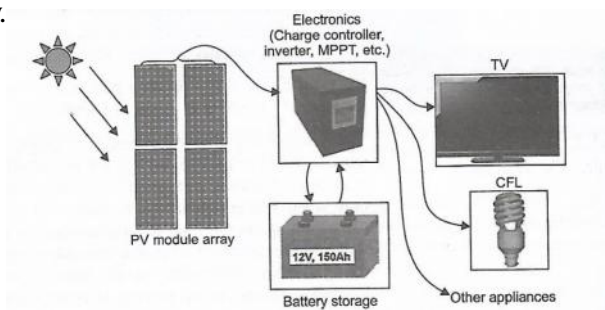

- Grid connected PV system (The PV System connected to the grid are called Grid connected PV system.)

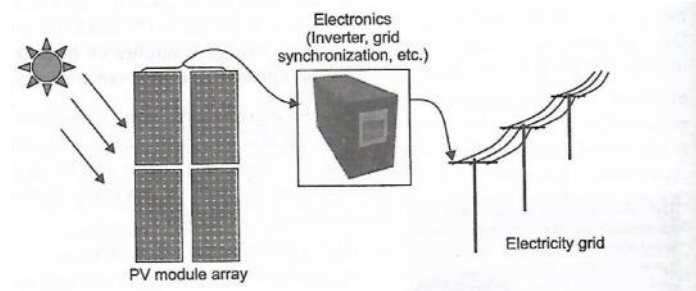

### Grid Connected Solar Power System

A grid-connected photovoltaic power system is an electricity generating solar PV system that is connected to the utility grid. A grid-connected PV system consists of solar panels, one or several inverters, a power conditioning unit and grid connection equipment. They range from small residential and commercial rooftop systems to large utility-scale solar power stations. Unlike stand alone power systems, a grid-connected system rarely includes battery system, as they are still very expensive. This system is used for installed capacity above 100 W. Connection of the photovoltaic power system can be done only through an interconnection agreement between the consumer and the utility company.

If photovoltaic wattage substantially exceeds average consumption, the energy produced by the panels will be much in excess of the demand. In this case, the excess power can yield revenue by selling it to the grid. Depending on their agreement with their local grid energy company, the consumer only needs to pay the cost of electricity consumed less the value of electricity generated.

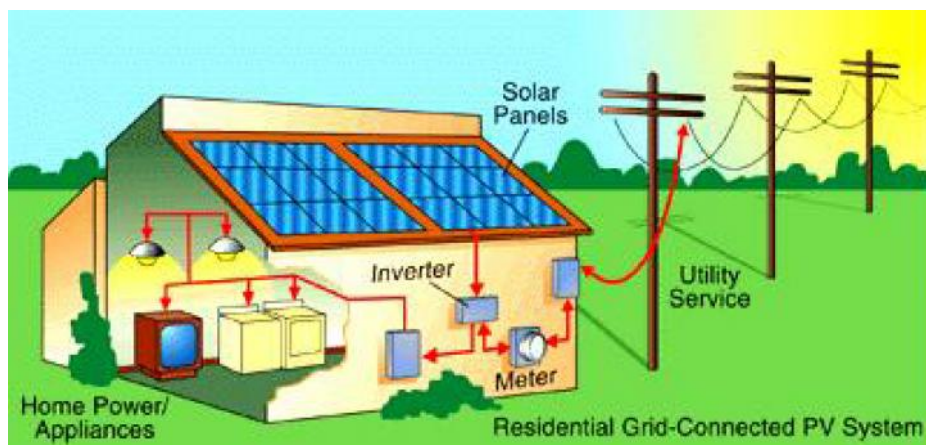

### ADVANTAGES

- Grid-connected PV systems are comparatively easier to install as they do not require a battery system.
- Grid interconnection of photovoltaic (PV) power generation systems has the advantage of effective utilization of generated power because there are no storage losses involved.
- A photovoltaic power system is carbon negative over its lifespan. Even though the sun doesn't always shine, any installation gives a reasonably predictable average reduction in carbon consumption.

### Grid Connected System with Battery Back Up

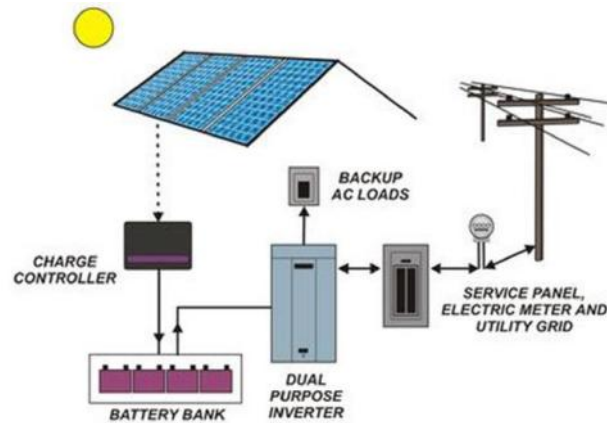

- Hybrid PV system. (Hybrid PV systems could be standalone or grid connected type. (It employs more than one power source- eg. solar & wind , solar & diesel generator etc.

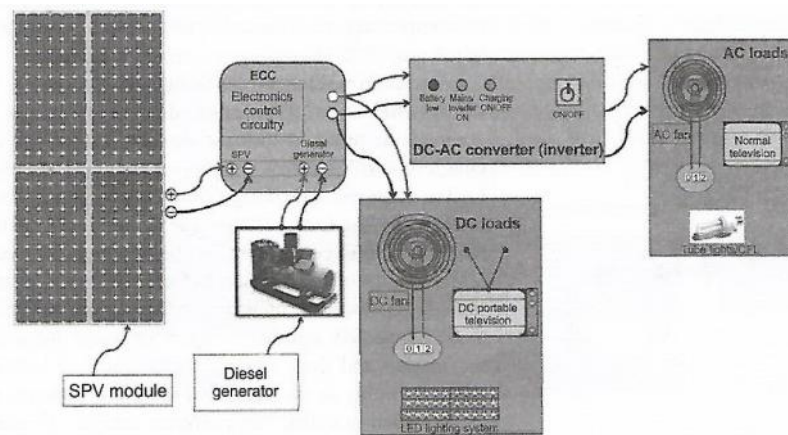



## Applications of Solar PV Systems

There are many practical applications for the use of solar panels or photovoltaics. It can first be used in agriculture as a power source for irrigation. In health care solar panels can be used to refrigerate medical supplies. PV modules are used in photovoltaic systems and include a large variety of electric devices such as Photovoltaic power stations, Roof top solar PV systems, Standalone PV systems, solar hybrid power systems., solar planes, Solar-pumped lasers, solar vehicles, Solar panels on space crafts and space stations etc.

## Solar PV System Installation

### Solar Panel Connection

The PV systems are designed to supply to electrical loads. The load may be of DC or AC types. Since a PV panel generates power only during sunshine hours, some energy storage arrangement is required to power the load during non sunshine hours. This energy storage is usually done by batteries.

Understanding installation and material usage procedure:

- Understand the customer requirement on installation.
- Ensure that all appropriate materials are available during installation time.
- Ensure that the installation meets the local building rules and regulations.
- Ensure to disconnect PV module from any electrical sources such as batteries, inverters etc. before working on the module.
- Check that the module is defect free before installing.
- Ensure to take specified measures such as fire resistance, corrosion resistance for the module during installation.

Assessing mounting:

- Understand the type of mounting and other accessories required.
- Assess the degree of inclination and angle of tilt of PV module for the specific area, locality or region to enable the system absorb maximum annual sunlight.
- Ensure that sunlight falls perpendicular to the PV module to absorb maximum energy.
- Ensure that panels are mounted in a place where there is no shade at any time of the year.
- Ensure that mounting is strong to withstand wind, rain, etc.
- Ensure that any special construction requirement for mounting is done by following acceptable quality standards, especially, in rooftop installations.

- Use approved tools for mounting.
- Set the mounting fixture firmly at the desired location.
- Installing the Panel:
- Remove packaging of the solar panel carefully.
- Handle the panels carefully without damaging the material.
- Take safety measures and wear protection gear such as gloves to avoid shock/injuries while handling modules.
- Cover the module with opaque material while installing to avoid any current generation.
- Ensure that junction box is covered.
- Do not disturb or disassemble any part of module part during installation.
- Take necessary precautions for fire resistance of modules.
- Use recommended material of solar cable and plugs for electrical connection.
- Install spare fuse to avoid any short circuits as per company policy.
- Mount the module on the fixture with the mounting rails using bolts and nuts.
- Ensure that the panels are mounted firmly.
- Connecting the system and check for functioning:
- Use the cables to connect multiple PV modules in combination to generate the desired voltage and current.
- Choose type of connection, ie, series or parallel, as per design.
- Use recommended cables to generate maximum voltage.
- Check the maximum system voltage as per the installation and follow adjustment measures accordingly to match output requirement.
- Ensure that the modules are grounded as specified.
- Connect the system and check for functioning.
- Escalate for any issues faced during the functioning of the system.

### **Solar PV Orientation**

A solar photovoltaic module or solar collector collects the maximum solar radiation when the sun's rays strike it at right angles. Sun tracking mechanism is not cost-effective but an adjustable (tilt angle) solar photovoltaic modules mount (south facing in northern hemisphere & north facing in southern hemisphere) with an appropriate tilt angle measuring scale, will be cost-effective.

A solar photovoltaic module generates more electrical power when more sunlight power incidents on it. The sunlight power incident on a module depends not only on

the power contained in the sunlight but also on the angle between the module and the sun's rays. When the sun's rays fall normally on the module's surface, the incident sunlight power is maximum.

There is some flexibility with the angle of tilt and Solar PV arrays can be tilted at an angle as low as 12 degrees. At this angle the system efficiency is only reduced by around 5 per cent and the angle is still steep enough to stop dirt building up on the Solar PV panels.

In order to get the most from solar panels, they must point in the direction that captures most sunshine. In India, as anywhere in the northern hemisphere, solar panels should face southwards. However, in the southern hemisphere, for example, in Australia panels should point towards north. Here North means the true north - not the magnetic north as pointed by the compass needle.

### **PV Mounting**

When planning to install a Solar PV system, the roof of the building is usually the most suitable place. This solution is effective where the roof is south facing or where the roof is flat and panels can be fitted using angled mountings. An alternative is to mount Solar PV panels on a wall. This can work well with longer, slimmer panels that can be mounted at an angle without protruding too far from the wall itself. It can also be fixed on ground with suitable mounting. Ground-based mounting supports include: 1) Pole mounts, which are driven directly into the ground or embedded in concrete. 2) Foundation mounts, such as concrete slabs or poured footings. 3) Ballasted footing mounts.

### **Safety precautions for installing solar photo voltaic system**

#### **General Safety**

- Ensure that the modules are used for the intended purpose only.
- When installing, operating and maintaining the PV system, observe all local, regional, national and international statutory regulations, guidelines, norms and code requirements.
- The safety information for other system components must also be followed.
- Keep children away from the module and PV system.
- Never work on bad weather or with wet tools
- Do not install PV Systems in locations that are corrosive.
- Do not work on PV systems alone. Always have at least one other person with you in case of accident/ Emergency.

### Handling Safety

- The utmost care is required when unpacking, transporting, and storing the modules. Leave modules in packaging until they are to be installed.
- Always store the modules in a dry, ventilated in-door space if possible. Carry modules with both hands. Do not use the junction box as a handle to hold or transport the module.
- Do not stand or step on the module.
- Do not drop module or allow objects to fall on module.
- Do not mark or scratch the front or rear surface of the module with sharp objects.
- Do not disassemble, modify or adapt the module such as drilling holes in the frame or glass. Do not apply paint or adhesive to the module rear surface.
- Do not remove any part or labelling.
- Keep all electrical contacts of module clean and dry. Do not handle modules when they are wet unless wearing the appropriate protective equipment.
- Do not leave a module unsupported or unsecured.
- Do not attempt to repair any part of the module. Broken or damaged modules must not be used and must be handled carefully and disposed properly.

### Installation Safety

- All installations must be performed in compliance with the National Electrical Code (NEC) and any applicable local codes by authorized personnel.
- Keep children away from module and the system when installing.
- Do not wear metallic jewellery while performing mechanical or electrical installation of modules to avoid accidental exposure to live circuits.
- When working with modules exposed to light, follow all applicable regulations regarding working with live electrical equipment.
- Do not install or handle the modules when they are wet or during periods of high wind.
- Always use insulated tools and rubber gloves that are approved for working on electrical installations to reduce the risk of electric shock.
- Always use equipment, connectors, wiring and support frames suitable for PV electric system.
- When installing modules on elevated locations, such as a rooftop, use caution to avoid falling or other safety hazards by following appropriate safety practices and using required safety equipment.

- PV modules do not have a power ON/OFF switch. The only way to make modules inoperative is removing them from light, or fully covering their front surface with an opaque material, or placing modules face down on a smooth, flat surface.
- Avoid setting the module down with any type of force on any surface particularly when placing it on a corner.
- To prevent untrained personnel from disconnecting the modules after installed, locking connectors and safety clips must be used in the installation.
- Do not touch electrical terminals or the ends of any wire while installing the module.
- Cover all modules in the PV array with an opaque cloth or material before making or breaking electrical connections.
- Broken junction boxes or broken connectors are electrical and laceration hazardous and cannot be repaired. Please contact the installers to remove the broken module from the array and contact the supplier for disposal instructions.

### Maintenance of Solar System

Solar systems require little maintenance as compared to other electric systems.

So, preventive maintenance is more crucial on major components of a solar PV system such as:

1. Battery
  2. Solar Panels
  3. Charge Controller
  4. Inverter
  5. Wiring and connections
1. Battery Maintenance
    - Battery inspection and cleaning.
    - Checking the electrolyte.
  2. Solar Panel maintenance
    - Keep the surface (glass) area of the module clean from any excess dirt.
    - A visual inspection of the modules can then be done to check for defects in the modules such as cracks, chips, de-lamination, fogged glazing, water leaks and discoloration.

- The condition of the array mounting frame should also be noted. Items to observe should include the array mounting bolts (e.g. bolt rusting) and checks to ensure that the frame and modules are firmly secured. The junction boxes should also be checked to ensure that the wires are not chewed by rodents or insects.
3. Charge controller, inverter and wiring
- This component can be maintained by minimizing dust accumulation. A dry cloth should be used to wipe away any accumulated dirt/dust. A visual inspection should be done to ensure that all the indicators such as LED lights are working and that the wires leading to and from this device are not loose. Note that the charge controller should indicate that the system is charging when the sun is up. If not, contact the installer immediately.

### Solar PV Devices

The appliances/ devices working on solar energy are termed as solar devices. There are many such devices. The commonly used devices include Solar lantern & solar street lighting system.

#### Solar Lantern

The main components of solar lantern are solar PV Module, a small rechargeable battery, electronic control circuit board and a lamp (CFL/LED). The whole components are placed in a suitable housing made of metal/plastic/ fibre glass.



#### Working

Solar PV Module converts sun light into electricity and it is then stored in a battery. The electronic charge control circuit control the charging and discharging rates. A lamp usually CFL/ an array of LED receives power from the battery and gives light, when switched ON.

Specifications of a white Light Emitting Diode (LED) light source Solar lantern system

- Light source - White LED
- PV Module - Between 2.5 to 5 watts
- Battery - Lead acid sealed maintenance free or Ni MH or Lithium Ion with a capacity up to 7AH, at voltages up to 12 V

- Protection against Open Circuit, Battery over charge & deep discharge, over load, reverse flow of current through the PV Modules, accidental short circuit and reverse polarity.

### Solar Street Lighting System

A Solar street lighting system consists of all the components in the solar lantern and some special components to install the lighting system such as

- pole system, solar panel & Panel bracket
- Maintenance free (Gelled) Battery & Battery box
- LED Lamp & housing
- Connecting Cable, Fitting etc.

In Solar street lighting system the Solar panel and lamp assembly are installed on the pole having suitable height and size. The automatic charge controller regulates the charging and discharging rate of the battery. Along with the charge controller, certain protective circuits are also incorporated in the circuit to prevent over load and reverse current flow.

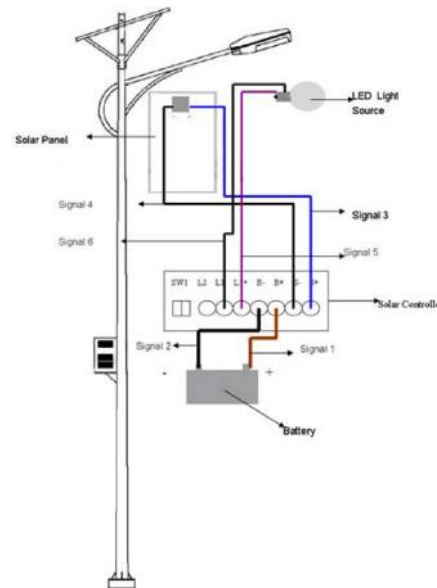

### Specifications of a Sample Solar Lighting System

- Pole Height - 4M to 12M (As per the requirement)
- Pole material - Plastic coated on hot-dip galvanized steel pole.
- Light Source - LED 9W to 100W (as per the requirement)
- Solar Panel - 30W to 240W
- Controller - To protect the system from over charging/ over discharging
- Battery - 38AH/12V, Sealed, maintenance free lead acid battery

#### *Extended Activity*

*Assemble a solar lantern/Solar street light as a Project work*

### **List of Practical Activities - Module 3**

1. Identify the parts of lead acid battery
2. Dismantling & assembling of lead acid battery.
3. Charging of lead acid battery.
4. Testing the condition of a Fully charged & discharged battery.
5. Precautions to be taken during maintenance of lead acid battery.
6. V I characteristics of a Zener diode.
7. Regulated power supply using IC 78XX and Zener diode
8. Common Emitter amplifier circuit.
9. Verification of truth table of logic gates.
10. Testing of Solar panel and measurement of voltages under different irradiations.
11. Open/short circuit testing of PV module by measuring voltage & current.
12. Maintenance of PV module.
13. Assembling and installing module/panel as per design.
14. Selecting & Installing battery as per the design.
15. Installation & Testing of inverter circuit.
16. Installing wiring system for solar equipment.
17. Assembling & Installing solar devices.
18. Series & Parallel connection of PV module to obtain desired voltage & power.



## Module - 4

### Servicing of common home appliances

The fourth module of EET named 'HOME APPLIANCE SERVICING' consists of three units such as Electrical Machines, Servicing of commonly used home appliances and Engineering Drawing. Electrical machines are included in this module to get a basic understanding of the construction, classification and working of D.C Machines & A.C Motors as to build a foundation to attain the module objective. The second unit Home appliances servicing comprises of the construction working and repairing of commonly used home appliances such as Electric iron, water heater, ceiling fan, Mixy, wet grinder and washing machine. The third unit named engineering drawing deals with the basics of engineering graphics, projection of points, planes and surfaces, isometric views, concept of development of surfaces etc. This unit also includes familiarization and use of Electrical Auto CAD.

### Unit - 1

#### Electrical Machines

##### Introduction

The first unit in the fourth module named Electrical machines deals with the construction, classification and working of D.C Machines & A.C Motors. It also includes the detailed study of different single phase induction motors. An attempt is also made to introduce the concept of Brushless D.C Motors.

##### Learning Outcomes

1. Comprehend the principle, parts and working of DC generator and types.
2. Comprehend the principle, parts and working of DC motor and necessity of Starter
3. Explain the principle of working of 3 phase induction motors.
4. Connect different types of starters (DOL, Star Delta)
5. Realise the working of different single phase motors and BLDC motor.

##### Concept Detailing

##### Electrical Machines

##### 1. DC Generator

An electric generator is a machine which converts mechanical energy into electrical energy. Its working is based on the principle of dynamically induced emf. ie Whenever a conductor moves in a magnetic field and cut the magnetic flux, an emf will be induced in it and a current flows if the conductor circuit is closed.

### Working of a generator

Imagine the coil is rotating in anti clock wise direction. At different position of the conductor, the flux linked with the conductor changes and hence an e.m.f is induced in that conductor. This induced e.m.f is directly proportional to the rate of change of flux linkage. The current obtained from a simple generator reverses its direction after every half revolution. Such a current undergoing periodic reversals is known as alternating current (A.C). For making the load current unidirectional commutator is used. They are made up of Copper conducting cylinder which is cut in to two halves (segments) and they are insulated from each other by a thin sheet of mica or other insulating material.

### Constructional details of a Generator

#### Parts of Generator

A D.C generator consists of the following essential parts.

- 1) Magnetic frame or Yoke
- 2) Pole coils or field coils
- 3) Pole core and pole shoes.
- 4) Armature core & Armature winding
- 5) Commutator & brushes
- 6) Shaft, bearings

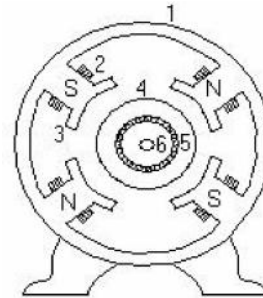

- 1) Yoke

The purpose of the yoke is to provide

- (i) Mechanical support to the poles and acts as a protective cover for the machine.
  - (ii) It carries the magnetic flux produced by the poles
- 2) Pole coils or field coils  
The pole coils or field windings consist of copper conductors. When current flows through these coils, they magnetise the poles which produces the flux.
  - 3) Pole core and pole shoes  
The field magnet consist of a laminated pole core and pole shoes. The windings for the electromagnets are wound on the pole cores. The pole shoes serve two purposes
    - a) It spreads the flux in the air gap and reduces the reluctance in the magnetic path.
    - b) They support the field coils.
  - 4) Armature core

The armature core carries the armature conductors and causes them to rotate in the magnetic field. In addition to this another function of the core is to pro-

vide a low reluctance path to the magnetic flux from north pole to south pole. It is cylindrical or drum shaped and made up of circular sheets steel laminated. The slots are provided in the outer surface of the core to carry the conductors. A key hole is located in the inner diameter to lock the shaft. Air holes are provided in the core for cooling purpose.

#### 5) Armature winding

These are windings made up of highly conducting copper conductors. These are placed in the slots cut in the armature core. There are two types of windings.

- a) Lap winding
- b) Wave winding.

In lap winding the number of parallel path = number of poles

In wave winding the number of parallel path = 2

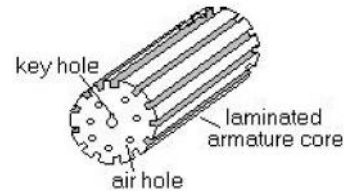

#### 6) Commutator

The function of the commutator is to collect the current from the armature conductors. It rectifies ( convert ) the alternating current induced in the armature conductors into unidirectional current in the external load resistance. It is made up of copper in the cylindrical structure.

#### 7) Brushes

The brushes whose function is to collect current from commutator and are made up of carbon. It is rectangular in shape. The reason for using carbon as brush contact is that the resistance of carbon decreases with increase in temperature. Another reason is that carbon is soft. So wear and tear will occur at the brush contact and not for the commutator segments.

### Types of DC Generators

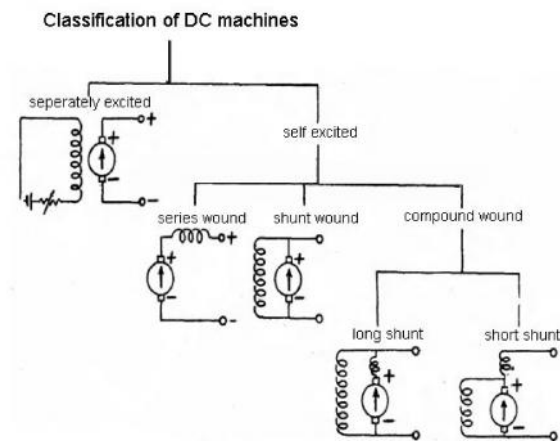

### Reasons for failure of voltage building up of a DC generators

- Defective contact of brushes with commutator due to dirt, insufficient pressure, tight brushes, dirty commutator, projecting inter segment micas etc.
- High resistance or open circuit in the field circuit, open circuit in resistance in regulator etc.
- Loss of residual magnetism.

### Losses in a DC generator

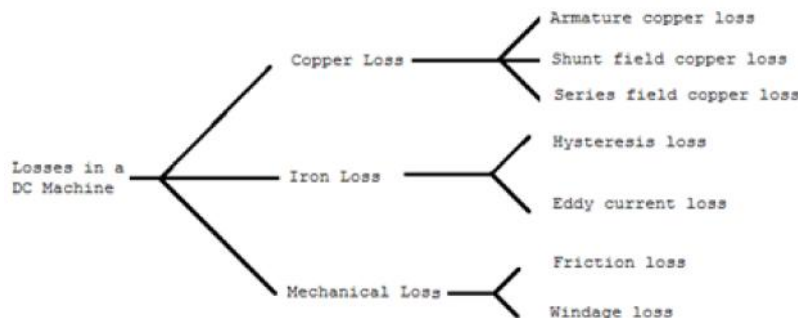

## 2. DC Motors

An electric motor is a machine which converts electrical energy into mechanical energy.

Its working principle is that whenever a current carrying conductor is placed in a magnetic field, the conductor experiences a force which tends to move that conductor. The direction of rotation of motor can be determined by Fleming's Left Hand rule.

### Fleming's Left Hand Rule

It states that if we kept the fore finger, middle finger and thumb of the left hand mutually perpendicular to each other such that the fore finger represents the direction of magnetic flux, middle finger represents the current direction, then the thumb indicates the direction of rotation of the conductor.

### Classification of DC Motors

D.C Motors are mainly classified as

- 1) Series wound Generator
- 2) Shunt wound Generator
- 3) Compound wound Generator

### Necessity of Starters in DC motors

At starting, back e.m.f of DC motor is zero. i.e.,  $E_b = 0$ . So armature current  $I_a = E/R_a$  (Since,  $E_g = E_b + I_a R_a$ ). It indicates that starting current will be dangerously high that it may equal to 5-6 times its load current (as armature resistance  $R_a$  is small). Hence it is necessary to use starter to limit the starting current to allowable lower value.

In its simplest form, the starter of a dc motor works like a variable resistance in series with the armature circuit. Its work is to reduce the starting voltage so that the increased current does not burn the armature windings. As the rotating armature of dc motor picks up speed, the starter resistance is gradually reduced to almost zero. At full speed the motor starts running normally.

### Application of dc motors

#### 1. D.C Shunt Motors

DC Shunt motor is a constant speed motor. i.e., remain almost constant speed from no load to full load. It is usually used in;

- Lathes
- Drills
- Boring mills
- Shapers
- Spinning and Weaving machines.

#### 2. D.C Series motor

D,C, Series motor has high starting torque It is a variable speed motor. On no load, the motor speed attains dangerously high.

It is commonly used in;

- Electric traction
- Cranes
- Elevators
- Trolley car

#### 3. D.C Compound motor

Differential compound motors are rarely used because of its poor torque characteristics.

This type of motors are used in:

- Presses Shears
- Reciprocating pump.

### 3. A.C.MOTORS

Classification of a.c.motors

According to the number of phases A.C Motors are classified into two

- Single phase motor
- Three phase motor

Three Phase Induction Motors - construction

Three phase induction motors are commonly used in industrial drives. It works on the principle of induction and hence the name induction motor.

There are two types of induction motors

- Squirrel Cage Induction Motor
- Slip Ring Induction Motor

An AC motor has essentially two parts

- a. Stationary part called Stator
- b. Rotating part called Rotor

#### STATOR CONSTRUCTION

Both Squirrel Cage Induction Motor and Slip Ring Induction Motor have similar stator construction. The stator has a laminated core on which slots are cut to carry the windings. Three distributed windings which is stator internally is placed in the stator.

The number of pole of the stator is determined by the speed of the motor.

$$N_s = \frac{120f}{p}$$

Where  $N_s$  is the synchronous speed

$f$  is the frequency of the AC supply

$P$  is the number of poles.

As the number of poles increases the speed decreases and as the number of poles decreases, the speed increases.

## ROTOR

### Squirrel Cage Rotor

This type of rotor has a cylindrical laminated core on which slots are provided to carry the windings. Here the winding consists of copper or aluminium bar which are welded together at both ends of the rotor called end rings and thus creating the shape of a cage. The motors which use this type of rotor are called squirrel cage motors.

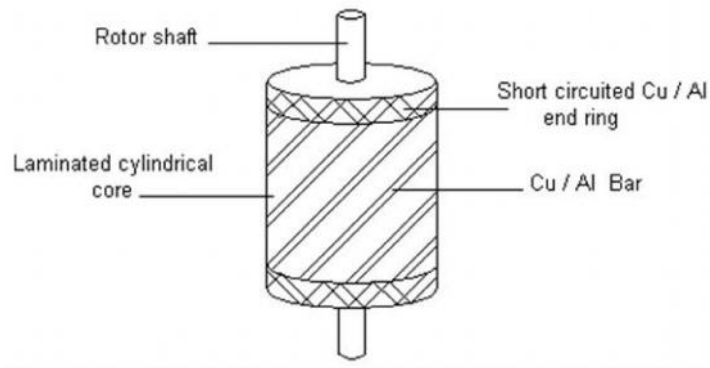

The slots are usually not parallel to the shaft because it increases the rotor resistance due to increased length of rotor bar. Slightly skewed rotor slots also help in reducing the locking tendency of the rotor, i.e. the tendency of a rotor to remain in the stator teeth due to magnetic attraction. This helps the motor to run quietly.

### Phase Wound Rotor / Slip Ring Rotor

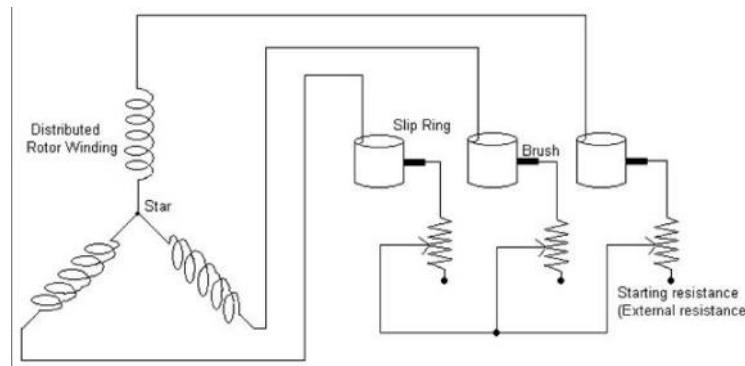

The rotor of a slip ring induction motor or wound rotor motor has a laminated core on which slots are provided to carry the three phase distributed winding which is starred internally like stator.

The other three ends of the winding are taken out and are connected to three insulated slip rings. A set of three carbon brushes rest on the slip rings. These brushes are connected to three rheostats which are also star connected.

By adjusting the rheostat we can adjust the resistance of the rotor circuit externally. This is employed during the starting period of the motor. The motors which use this type of rotor are called slip ring motors.

Comparison between Squirrel cage and Slip ring motor

Sl.No.	Particulars	Squirrel cage	Slip Ring
1	Construction of rotor	Rotor conductors are shorted at the ends by endrings.	Ends of rotor windings are connected to slip rings
2	Cost	Cheap	Costly
3	Efficiency	High	Low
4	Starting torque	Low	High
5	Maintenance cost	Less	More

### Working of Three Phase Induction Motors

The principle of working of 3 phase induction motor is Mutual induction. Here supply is not directly given to the rotor.

When the three phase stator winding of an induction motor is fed from a three phase A.C supply, a magnetic flux is set up in the stator windings. This magnetic flux is of constant magnitude but rotating round the air gap at synchronous speed ( $N_s$ ).

This rotating magnetic flux passes through the air gap and cuts the rotor conductors which are stationary. Therefore an emf will be induced in the rotor conductors. As the rotor forms a closed circuit, a current will flow and hence a torque is produced in the rotor. According to Lenz's law, the induced e.m.f always opposes the cause which produces it. Here the cause is the relative speed between magnetic field and the rotor. Hence to reduce the relative speed, the rotor start to rotate in the same direction as that of the magnetic flux and tries to catch up the rotating magnetic field.

But the rotor never catches up the speed of the rotating magnetic field and only rotates at a speed less than the synchronous speed.



### Production of rotating magnetic field

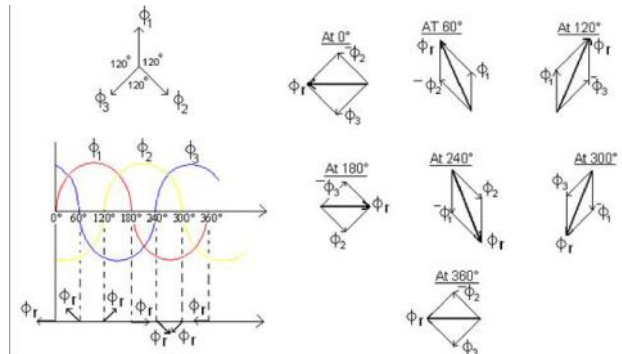

### Synchronous Speed ( $N_s$ )

It is the speed at which the magnetic flux produced by the stator magnetic poles of an induction motor is rotating.

$$N_s = \frac{120f}{p}$$

The synchronous speed of a motor can be increased by decreasing the number of poles.

### Slip

When three phase supply is given to the stator of the induction motor, a magnetic field rotating at synchronous speed ( $N_s$ ) is set up and due to this the rotor starts rotating at a speed ( $N_r$ ) which is always less than the synchronous speed. ( $N_r < N_s$ )

The difference of synchronous speed ( $N_s$ ) and rotor speed ( $N_r$ ) is called as slip of the motor. Usually slip is expressed in percentage and it is calculated as

$$\% \text{ Slip} = \left( \frac{N_s - N_r}{N_s} \right) \times 100$$

### Importance of slip

If the slip of an induction motor is zero, then there would be no relative speed between magnetic field and the rotor. There for the change of flux linking with the rotor conductor is zero and hence there is no rotor emf and no rotor current. So no torque to maintain rotation. The motor will not rotate when the slip becomes zero.

### Speed control of induction motor

- Squirrel cage motor

In the case of squirrel cage motor, there is no external connection from the rotor. So speed can be changed only by changing the number of poles of the stator.

$$\text{Speed } N_s = \frac{120f}{p}$$

If the number of poles increases, speed decreases and vice versa.

### Slip ring induction motor

In case of slip ring induction motor, the resistance of the rotor circuit can be changed by adjusting the rheostat connected in series with it. So speed can be adjusted by this method. Also by changing the number of poles of the stator, the speed can be varied.

### Motor Starters

Functions of a starter

- To start and stop the motor
- To limit the inrush (high starting ) current where necessary
- To permit automatic control when required
- To protect the motor and other connected equipment from over load, no voltage, under voltage, single phasing, and earth fault.

### Star - Delta Starter

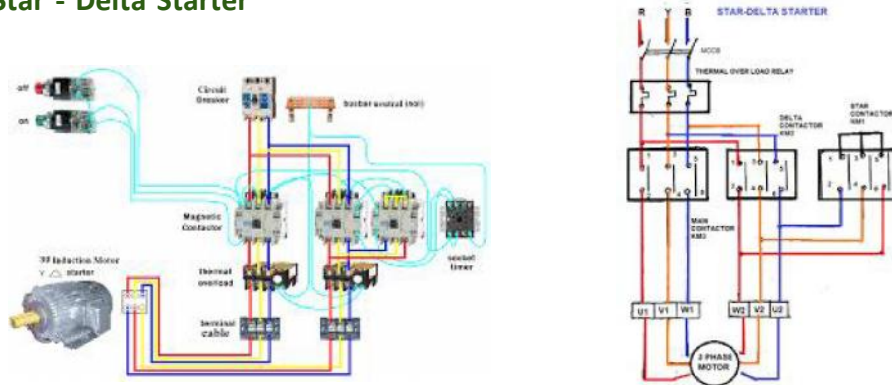

Circuit Diagram of Automatic Star-Delta Starter

Actual Connection diagram using Star delta starter is usually used for starting three phase induction motor with a delta connected stator winding. The diagram is as shown above.

At first the stator winding of the motor is star connected with the help of a two way switch. As it is in star connection, phase voltage is equal to line voltage divided by  $(V_{ph} = V_L / \sqrt{3})$ , a reduced voltage is applied to the motor during starting. Hence the starting current will be reduced to 1/3rd of direct connection to supply. As the

motor starts running the stator connection is put into delta by means of a two way switch. As in delta connection line voltage is equal to phase voltage ( $V_L = V_{ph}$ ) and hence normal line voltage is applied to the motor and motor runs at normal speed taking normal current.

### DOL Starter

This starter is normally used for motors of rating up to 5 HP. The internal connection of starter is as shown in figure. When the start button is pressed the contact closes and the electro magnet become magnetised and attracts metallic strips to short M1, M2, M3 to L1, L2, L3 respectively through over load release heating contact. The auxiliary contact (C2) works as an inter-lock. That is when the start button is released after pressing, the auxiliary contact passes the current.

Due to any reason (over load or single phasing etc.), if the load current increases, the over load heating element becomes hot and the metallic strip bends and it open the over load switch OLDC. Hence the circuit of the no volt coil (NVC) becomes open and the electro magnet demagnetised and the metallic strip comes to the open position. Thus the motor windings are disconnected from the supply.

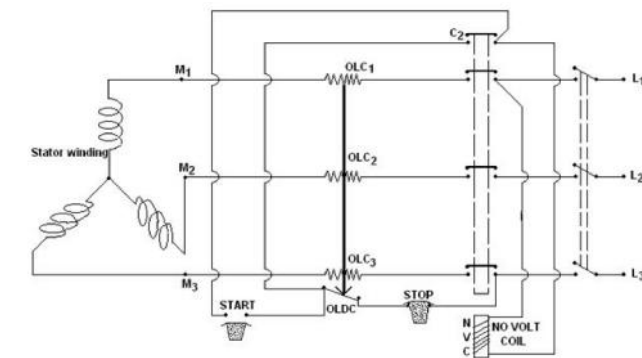

### Single Phase Induction Motors

"Single phase induction motors are not self-starting". Why?

When three phase supply is given to the stator winding of a three phase induction motor, a rotating magnetic field is produced in it due to which an emf is induced in the rotor. Since it is a closed circuit, rotor current flows which can produce the rotating torque. So three phase induction motors are self-starting.

In the case of single phase induction motor, when single phase supply is applied to single phase stator winding, only an alternating magnetic field is produced which cannot produce any rotating torque in the rotor. Hence single phase induction motors are not self-starting.

### Split Phase Motor

This type of motor is temporarily changed into two phase during starting period. The stator of the motor has two winding - starting winding and running winding.

Running winding is directly connected across the supply. While starting winding is connected in series with an automatic switch & starting device. Running winding has high inductance & low resistance. But starting winding has high resistance & low inductance.

### Capacitor Start Induction Motor (CSIR Motor )

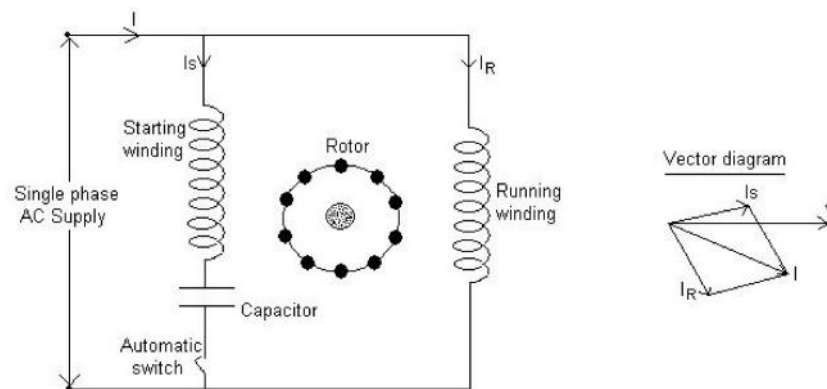

It is similar to the construction of a split phase motor except that a capacitor is connected in series with the starting winding and the automatic switch (centrifugal switch).

The stator has two winding- starting winding & running winding. The running winding which is having high inductance and low resistance is directly connected across the supply while starting winding which is having high resistance and low inductance is connected in series with an automatic switch and a capacitor. When the motor is running at normal speed, the switch automatically disconnects the starting winding and the capacitor from the supply line.

When the motor is switched ON, the switch connects the running winding along with the starting winding and the capacitor. The current through the running winding ( $I_R$ ) lags the applied voltage by a large angle and current through the starting winding ( $I_s$ ) leads the voltage by a small angle. Hence a phase difference of almost  $90^\circ$  is obtained here which can produce a rotating magnetic field in the air gap and hence an e.m.f. will be induced in the rotor conductors. Since the rotor conductors form a closed path, a current flows through it and hence a torque is produced in the rotor. Thus the motor starts working.

This type of motor has a high starting torque, high efficiency and high power factor. This type of motor is used in lathe, drilling machine etc.

### Permanent Split Capacitor Motor (PSC Motor )

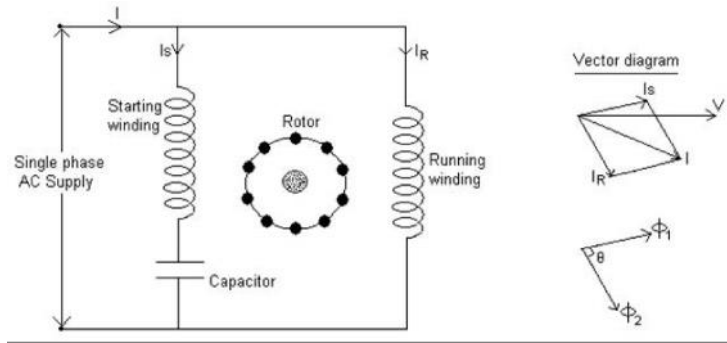

It is similar to that of a CSIR motor except that the capacitor and the starting winding are permanently connected across the supply. So there is no need of switch. It is used in table fan, ceiling fan etc.

The stator has two windings - starting winding and running winding. The running winding has high inductance and low resistance. The starting winding has high resistance and low inductance.

When the motor is switched ON, the current through the running winding ( $I_r$ ) lags the applied voltage by a large angle and current through the starting winding ( $I_s$ ) leads the voltage by a small angle. Hence a phase difference of almost  $90^\circ$  is obtained here which can produce a rotating magnetic field in the air gap and hence an e.m.f. will be induced in the rotor conductors. Since the rotor conductors form a closed path, a current flows through it and hence a torque is produced in the rotor.

In this type of motors, a capacitor of low capacitance are used and hence it has a medium torque.

### Shaded Pole Motor (Phase Shift Motor)

In shaded pole motor, the necessary phase splitting is produced by induction. It has a salient pole (projected) stator and a squirrel cage rotor. The stator field windings are connected in series as shown in figure. Each laminated stator pole has

a cut across it (at about  $\frac{1}{3}$ rd distance from one edge). A short circuited copper coil is placed around the smaller portion as in the figure.

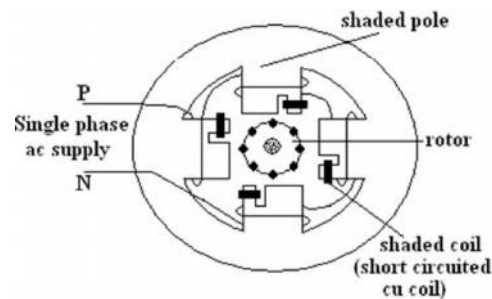

### Working

When the single phase supply is applied to the field winding of the motor, a magnetic field is set up in the core. The magnetic axis is shifted from the unshaded portion to the shaded portion of each pole. It is equivalent to an actual shifting of magnetic poles. Hence an emf is induced in the rotor according to Faraday's laws. So a current flows through it and a torque is produced which will make the rotor to rotate in the same direction (according to lenz's law). So the motor is self starting. Though the motor is cheap, it is used in electric clock, small fan etc.

### Universal motor

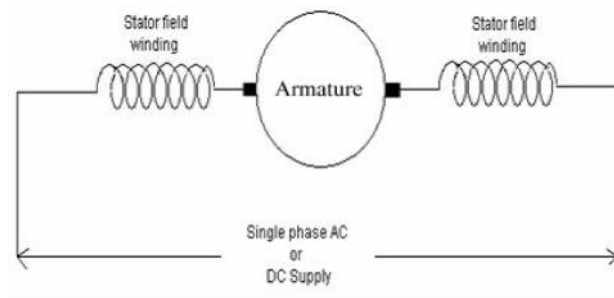

A universal motor is a motor which can operate either on DC or AC single phase supply. It is also known as A.C Series motor. The stator of this motor has two salient poles with a laminated core to reduce eddy current loss. Rotor is also laminated and the windings are placed in the slots. The rotor winding is connected in series with the stator field winding as shown in figure. When the supply is given, (AC or DC) a magnetic field is produced in the stator windings and at the same time the rotor conductors carries a current. Hence the rotor starts rotating (whenever a current carrying conductor is placed in a magnetic field, a torque is produced in that conductor). The motor always produces uni-directional torque. The direction of rotation can be changed by inter changing the field connections. Universal motor is used in hair drier, kitchen appliances, sewing machine motor, vacuum cleaner, mixer grinder etc.

### BRUSHLESS D.C MOTOR

Brushless DC motors are high-power motor which can deliver large amounts of torque over a range of speeds. BLDC motors are electronically commutated constantly changing the waveforms being delivered to a wound stator. Brushless motors with an outer rotor tend to operate at lower speeds and have high output torque. Those with an inner rotor have lower rotor inertia and therefore higher output speed.

Commutator helps in achieving unidirectional torque in a typical D.C motor. Commutator and brush arrangement is eliminated in a brushless dc motor. An integrated inverter / switching circuit are used to achieve unidirectional torque. That is why these motors are, sometimes, also referred as 'electronically commutated motors.

### Construction of a BLDC Motor

Just like any other electric motor, a BLDC motor also has a stator and a rotor. Permanent magnets are mounted on the rotor of a BLDC motor, and stator is wound with specific number of poles. This is the basic constructional difference between a brushless motor and a typical dc motor.

There can be two types of BLDC motor on the basis of construction: (i) inner rotor design & (ii) outer rotor design.

Advantages of BLDC motors include: responsiveness, quick acceleration, reliability, long life spans, high speed operation and a high power density. You can find brushless DC motors in applications like medical equipment, cooling fans, cordless power tools, turntables and automation equipment.

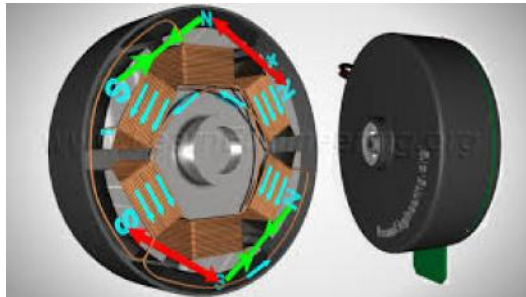

### Working Principle

Stator windings of a BLDC motor are connected to a control circuit (an integrated switching circuit). The control circuit energizes proper winding at proper time, in a pattern which rotates around the stator. The rotor magnet tries to align with the energized electromagnet of the stator, and as soon as it aligns, the next electromagnet is energized. Thus the rotor keeps running.

### Stepper Motors

Stepper motors are brushless DC motors that divide a full rotation into a number of equal steps. Instead of continuously rotating, a step motor rotates in stepped angles. Hybrid stepper motors have a magnet-bearing shaft that's surrounded by an electromagnetic stator. When it's energized, the stator aligns itself with the rotor and rotates the motor. The motor makes small movements, or steps, that keep it positioned accurately and synchronized with the magnetic field produced. Stepper motor

varieties include: permanent magnet stepper, variable reluctance stepper hybrid stepper, and permanent magnet stepper

### **Brushless Vs. Brushed DC Motor**

- Brushes require frequent replacement due to mechanical wear; hence, a brushed DC motor requires periodic maintenance. Also, as brushes transfer current to the commutator, sparking occurs. Brushes limit the maximum speed and number of poles the armature can have. These all drawbacks are removed in a brushless DC motor. Electronic control circuit is required in a brushless DC motor for switching stator magnets to keep the motor running. This makes a BLDC motor potentially less rugged.
- Advantages of BLDC motor over brushed motors are: increased efficiency, reliability, longer lifetime, no sparking and less noise, more torque per weight etc.

### **TE Questions**

1. Single phase induction motors are not self starting. Why?
2. "A CSIR motor is not working even after switched ON." List the possible faults and remedies.



## Unit - 2

### Servicing of Common Home Appliances

#### Introduction

This module consists of identification of parts, working, fault finding and repairing of common home appliances such as electric iron, water heater, ceiling fan, pedestal fan, mixer grinder, wet grinder and washing machines. This unit also explains the installation, precautions, working and servicing of water pumps.

#### Learning Outcomes

- Carry out servicing of Electric iron and water heater.
- Carry out servicing & repair of ceiling fan, Wall mount/Pedestal fan.
- Carry out servicing & repair of Electric Mixer.
- Carry out servicing & repair of Wet Grinder.
- Carry out servicing & repair of Washing Machine.
- Install and maintain water pump.

#### Concepts Detailing

There are many types of domestic appliances, which are being used, in day-to-day life. The working and servicing procedure of some of the commonly used domestic appliances such as electric iron, water heater, fan, mixer, wet grinder, washing machines and water pump are given.

#### Electric Iron

Electric Irons are used for ironing garments. There are two types - Non automatic and Automatic

##### Non Automatic Iron

- A - Ebonite Handle
- B - Element
- C - Sole plate
- D - Supply cord
- E - Pressure plate
- F - Case

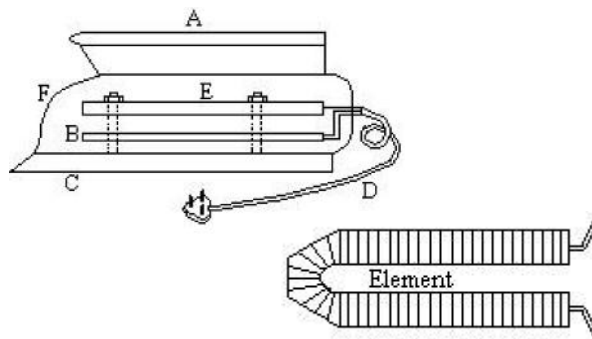

Non Automatic Iron has a chromium plated base plate, mica covered nichrome heating element, pressure plate on heating element, asbestos sheet, chromium plated case, ebonite handle and terminal base. The base plate (sole plate) of the iron is heat up. The element will not come in contact with air and there is less chance for burning. The iron should be earthed well.

The power of heating element ranges from 450 watts to 1000 watts. There is a chance for over heating of heating of element, as there is no thermal control. The element is fitted between sole plate and pressure plate tightly to prevent air contact. Handle is made of heat resistant material. Porcelain beads are used at the connecting leads between the cord and element as a protective measure.

### Automatic Iron

- A - Ebonite Handle
- B - Indicator
- C - Element
- D - Sole plate
- E - Bimetallic thermostat
- F - Temperature control knob

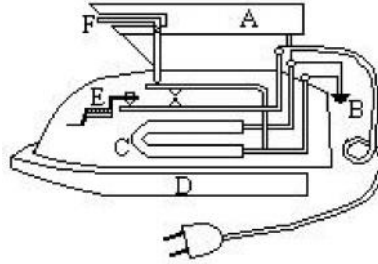

In an automatic iron, a bimetal thermostat is fitted to adjust the temperature for different clothes. At the desired temperature the thermostat opens and cuts off the supply. When cooled, it resets automatically. An indicator lamp is there which glows when the heating element is on.

The main parts in an automatic iron is similar to that in non-automatic iron. The additional parts include, a thermostat control and indicator lamp. There is no pressure plate. Element is made by fixing the nichrome wire surrounded by porcelain powder inside a metal tube. Some times the element is fixed in the base plate.

The power of the heating element ranges from 750 to 1000 watts. Indicator is connected in parallel with the element. If the bottom of the sole plate is teflon coated, the iron is called non stick type.

### Servicing

- Iron not working
  - The cord wire defective. Remove the cover of the three pin top and check the continuity of the three wires. Change the cord if defective.
- Thermostat is not making contact. Dismantle the iron and check by shorting the thermostat. If the contact is defective clean using emery paper or replace it.
- Element is burnt. Dismantle the iron and connect the supply to the ends of the element. If there is spark when connecting and if the element is heating up, it is not defective. If the element is defective, change it if replaceable.
- There is shock on the iron body
  - Check the earthing and shorted wires.

- Iron is sticking on the garments  
Iron bottom is dirty. Clean using emery paper.
- Iron is working, but the indicator do not glow.  
Check and repair the indicator bulb and its connections.
- Fuse blown off as soon as the iron is switched on.  
Check for touching of wire ends in the plug top or touching of elements ends together. If so separate and insulate them.  
Check the capacity of the fuse. If it is of low capacity replace it with correct one.

### WATER HEATER

Parts of Water heater

A	-	Lid bush
B	-	Outer body
C	-	Inner tank
DL	-	Outlet
E	-	Glass wool
F	-	Heating element sheath
G	-	Element
HM	-	Inlet
I	-	Sheath
J	-	Thermostat
K	-	Drain plug
N	-	Door plate
O	-	Pressure vacuum release valve
P	-	Packing

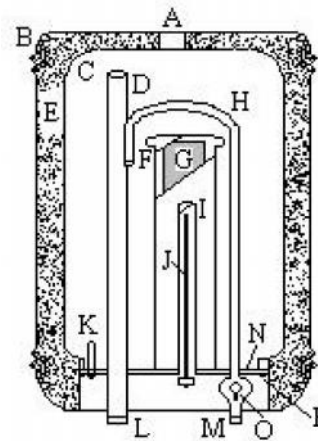

Water heaters are used to heat water for bath and other purposes.

The inner tank of the heater is made of hard and thick copper and outer case is made of iron sheet or fibre. Between these a heat insulator (glass wool or poly urethane foam) is filled.

Door plate is fitted at the bottom of the inner tank with rubber packing above it. Sheaths for thermostat and heating element and inlet - outlet pipes are connected to the door plate.

Thermostat which is fitted inside the sheath is operated by the expansion of metals when heated. By opening the cover below the heater, screw at the bottom of the thermostat can be adjusted for the required temperature of water.

The wattage of the element ranges from 1000W to 3000W. The elements are fitted inside sheath or directly in water with packing.

Pressure release valve is connected to the water inlet pipe. If the thermostat is defective, heater element will be energised continuously and water changes to high pressure steam, which may result in explosion of the inner tank. To prevent the explosion, pressure release valve opens this time and allow high pressure steam to pass out.

Pressure come vacuum release valve also be used some times. This is to prevent contraction of inner tank when vacuum is created inside. When there is vacuum the valve opens inward to allow outside air to enter and when there is high pressure it opens outwards.

#### Servicing

1. Heater is not working.

If there is power supply in the plug and the service cord is not defective, thermal cut out or thermostat is faulty. Test by shorting each and change the defective. If thermostat is not cutting off thermal cut out may open. Reset the thermal cut out after cooling.

If there is no spark when the supply wires touching the heating element terminals directly, it is defective. Replace the element with same power.

2. Water is not heating well and indicator glows continuously.

Element is weak. If the current drawn by the element is low it is weak. Change it.

3. Indicator goes off before water is heating well.

Thermostat is cutting off. Adjust its screw for the higher temperature.

4. High pressure steam forces out, opening the pressure release valve.

Thermostat is not cutting off and water changes to high pressure steam. Change the thermostat.

5. Water leakage through inner tank.

Leakage may be through the packing below the element, doorplate packing, element sheath, thermostat sheath. If the leak is through packing, change it. If the leakage is through element or thermostat sheath, weld that point after removing door plate. If the leak is through the sheath of open coil element, the element also may be damaged. Check it and repair.

6. There is electric shock on the heater body  
 Check the earthing. The body should be connected to the earth pin and power supply should be connected to earth.  
 Wires are wet because of the leakage of inner tank. Check and repair.

## ELECTRIC FAN

### Ceiling Fan

The electric fan is one of the most common household appliances, which is designed to circulate the air within a room. Usually there are two types of fans used in homes such as table fans and ceiling fans, the construction and working principle are more or less same. A Fan in its simplest form consists of a small single-phase permanent capacitor type induction motor having three or four impeller like blades mounted on its shaft. Capacitor is of type 2 to 2.5 microfarad 450V. The fans are specified by stating the sweep and the power rating. The average power consumption of a medium size fan ranges from 60 to 100 watts. The fan is factory wired for the correct rotation and only changing the connection of either the starting winding or the main winding can change the direction of rotation. A resistance type or an electronic regulator can be used to control the speed of a fan. The regulator and ON/ OFF switch are connected in series with the phase line to the fan motor. Neutral line is directly connected to the fan.

The main parts of a ceiling fan are a P.S.C motor, top and bottom canopy, blades, hanging rod and two ball bearings. The motor has stator and rotor windings, the rotating part is called as the rotor (outer winding) and the stationary part is called stator or armature (inner winding), which is mounted on the shaft. For overhauling of ceiling fan, wash out the bearing in

kerosene oil or petrol. See that they may rotate easily and apply proper grease in bearings. Remove the dust of winding by blowing air on it and clean all the parts.

### Precautions

- 1 Do not operate at low voltage.
- 2 Switch on the fan only at 'low speed' and then increase the speed step by step.
- 3 Lubricate the bearings periodically with grease.

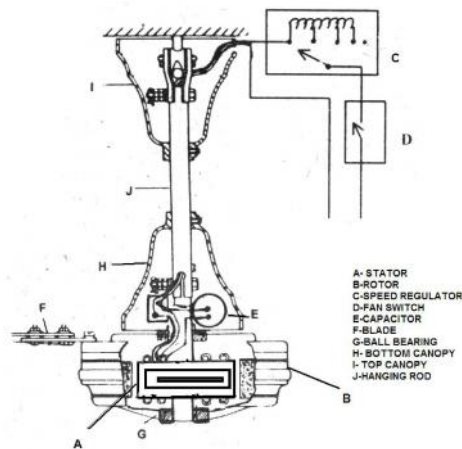

### Servicing of Ceiling Fan

Trouble	Cause	Remedy
Fan 'dead'	a) Open circuit in the regulator. b) Common lead broken. c) Switch trouble. d) Faulty Capacitor.	a) Check and repair if defective. b) Check and rewire. c) Repair or replace. d) Check and replace if defective.
Fan rotates with rough sound.	a) Defective bearings. b) Incorrect alignment of blades.	a) Replace the bearing. b) Align the blades properly.
Fan rotates but slow	a) Under voltage. b) Weak Capacitor. c) Burnt winding.	a) Check b) Check the capacitor by connecting to a.c supply and replace if defective. c) Check and rewind
Fan 'hums'	a) Faulty Capacitor. b) Stuck bearings. c) Burnt winding.	a) Check the capacitor by connecting to a.c supply and replace if defective. b) Check and apply grease or replace. c) Check and rewind.
Fan gets no speed regulation	a) Regulator resistance shorted or Faulty electronic regulator	a) Replace the regulator resistance or Regulator.
Fan vibrates while working.	a) Incorrect alignment of blades.	a) Align the blades properly.
Fan rotates slow in reverse direction	a) Faulty Capacitor b) Reversed connection	a) Check and replace. b) Check and rewire.
Electric shock on the fan body.	a) Bare live wire in contact with the metal body of fan.	a) Test with series test lamp set for ground. Locate the defective wiring and repair.

### Pedestal Fan

There are two windings for this PSC motor. Main winding is directly connected to the supply lines. A running capacitor of 2 or 2.5 MFd is connected in series with the auxiliary winding. Capacitor, switch and resistance are fitted inside the fan stand. Motor operates at a high speed. If one of the supply lines is connected through the resistance, fan speed decreases.

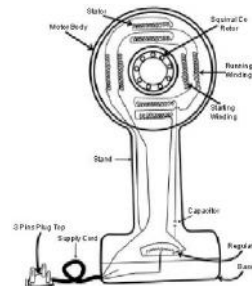

For side wise oscillation of the fan, a gear mechanism is fitted at the back of the fan motor. When the button is pressed, the metal ball fitted on the stem at the bottom is locked at the centre of the rotating toothed wheel. Thus, stem also rotates, moving the fan both sides alternatively. Motor shaft rotates inside the two brush bearings made of gun metal. Two small holes are provided on the motor body for oiling these bush bearings.

In Ceiling fans, the rotor surrounds the stator and it rotates in the counter-clockwise direction. Where as in a pedestal fan, the rotor is placed outside the stator and moves in clockwise direction. The construction and working of wall mount fan is similar to that of pedestal fan except the stand.

### Electric Mixer (Mixy)

The electrically operated food mixer (Mixy) is a most useful Kitchen appliance used to perform numerous mixing and food grinding process. It consists of a base or speed regulated electric motor, blades and a bowl with lid in which the food to be processed is placed. A fan is fitted on the shaft to cool the motor windings.

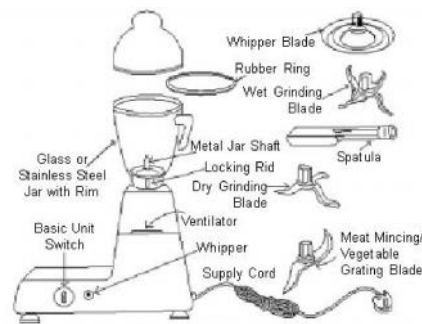

Fig. 4.9 Parts of Mixer Grinder

The motor used is a universal motor of high speed (about 18000 rpm) and is fixed in such a way that its shaft is brought out vertically and compiled to the blades that are inside a bowl with suitable rubber couplers. The bowl and blades are made of stainless steel and the lid with transparent hard plastic.

The operation of mixer can be understood in this way. Different fruits or liquid products are put in the bowl and covered with the lid. When the supply is switched ON, the motor rotates at high speed and the blades attached with the shaft moves very fast and grind the fruits and mix the liquid products. The speed of the motor can be controlled with switch knob and normally 3 speeds such as low, medium and high are available.

If the mixer is operated by putting more materials or at low voltage, motor draws over current, then over load protector open the contact to prevent the damage of windings. After tripping the over load, allows some time to cool and then reset by pushing the over load button to put ON the mixer again. The normal power rating of a mixer is 500 to 750 Watts.

### Precautions

1. Do not operate at low voltage/no load
2. Do not fill more materials in the jar.

3. Do not operate continuously.
4. Switch on the mixy at 'low speed' position only then increase speed.
5. Put on the mixy only after placing the jar correctly in the locked position.

#### Trouble shooting chart of mixy

Trouble	Cause	Remedy
1. Mixy is not working - no noise	Over load protector cut 'off' Brush is stuck at the slot Brushes are worn completely Broken connecting wires	Reset the over load protector switch or replace if defective. Take out the brush clean and reset Remove and replace with same size brushes. Check and rewire.
2. Mixy is not working but hums	Over load Stuck rotor shaft Burnt winding Defective bearing	Check and remove the over load Clean and lubricate the bush bearing and check Dismantle, check and rewind. Check and replace.
3. Mixy rotates very slowly and sparking at brushes	Burnt winding	Check and rewind if burnt.
4. Mixy operates only when the rotor is in a particular position	Rotor winding connections are broken from some of the rotor segments.	Take out the rotor, check and rewind if burnt
5. Mixy hums only, when the jar is placed	Jar stem stuck in the bush Stem is loose in the jar.	Take out the stem, clean, lubricates reset.
6. Water leaking from the bottom of the jar		Either change the bush or stem.
7. Mixy makes Noise during operation. a) With jar b) Without jar	Jar bush is worn. Motor bush bearing is worn.	Change the bush bearing. Change the bush.
8. Operator receives shock	Bare live wire in contact with the body	Check with series test lamp, locate the earth fault and rewire.



## Wet grinder

The wet grinder is used to grind wet materials.

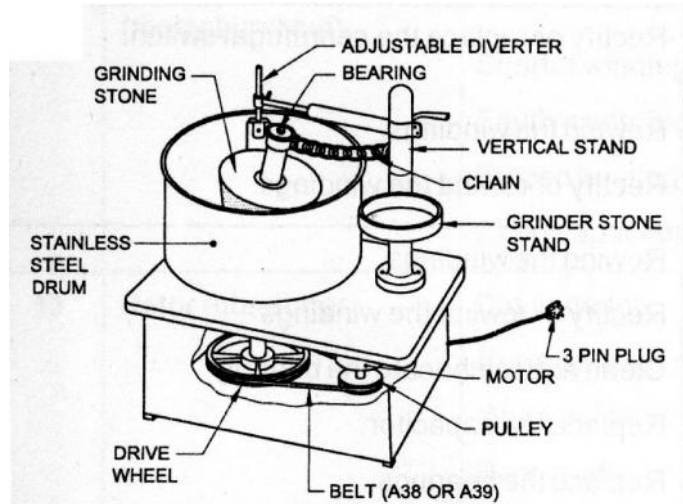

The main part of a wet grinder are a. C.S.I.R motor of 0.2 to 0.5 H.P capacity two vessel type stones, pulleys, bearings, belt and one stopper plate. The induction motor is mounted vertically, but rests on a ball bearing through a shaft, which is capable of rotating. The rotation of the stone vessel is achieved by coupling to the induction motor by a belt. The tension of the belt can be adjusted. The grinder motor, pulleys and belt are enclosed in a case made of plywood, fiber or steel. The roller type stone is suspended and is resting on the groove of the vessel type stone. The material to be grinded is placed in the vessel type stone and as when it rotates the material is grinded. Most of the grinders operate in clockwise direction and when the direction of rotation changes grinding will not be possible. For grinding more materials at a time and to prevent over heating of motor, it is good to use motor with higher rating.

### Trouble Shootong and Servicing of Wet Grinder

Trouble	Probable Cause	Remedies
1. Grinder is not working	No power supply or no voltage supply available at the motor.	Check the plug, motor switch and wiring to locate any open circuit and then rectify it.
2. Motor 'hums' and fuse blown off after starting	Faulty capacitor Faulty centrifugal switch Burnt motor winding Stucked motor shaft in the bearing	Check and replace Check, repair or replace Check and rewind Clean the parts, apply grease and make free

Trouble	Probable Cause	Remedies
3. Grinder speed is low	Low voltage Loose belt Motor shaft is not freely moving Motor winding burnt	Check and rectify Adjust the tension of the belt or replace Dismantle and apply grease Check the windings after dismantling the motor and rewind if required
4. Grinder makes noise while working	Worn bearings	Check and replace
5. Operator receives shock	Bare live wire in contact with the body of the grinder	Check for earth fault with series test lamp locate the fault and repair it.
6. Machine is working but not grinding well	Stones are smooth Low speed due to loose belt	Make the stones rough using special chisel. Adjust the belt tension or replace belt.

### Tilting Type Wet Grinder

Taking out of grinded materials from the ordinary grinder is difficult. Washing and cleaning of this type of grinder also is not easy so now a day tilting type wet grinders are used. In this type of grinder the bottom vessel can be tilted forward or backward completely therefore taking out the material and cleaning is easy.

The motor used is CSIR/PSC type 0.2 and 0.3hp. It consists of a circular shaped vessel of fiber with a grinding bottom stone. Two or three roller shaped stones are mounted on the top of the shaft inside the vessel and passing through the oil seal flitted at the center of the bottom stone. The wet material to be grinded is placed in the vessel and the vessel rotates similar to that of an ordinary grinder. Oil seal prevents the leakage of water and other liquids. In addition to the faults of an ordinary grinder, tilting type-wet grinder has the following faults also.

- When the switch is put on motor not works but hums- this may be because of the over tightened stones. For checking this, remove the belt and check the working of motor only. If working with normal current, repair the stuck stones.
- Water is leaking down from the machine-. This may due to the defective oil seal and bush bearing. In such case, change oil seal and bush hearing. While replacing oil seal, use oil seal of same number and similar bush.

### Precautions of wet grinder

1. Excess materials should not be put inside the grinder.
2. Sufficient water should be added to the materials while grinding.
3. Grinder should not be operated on low voltage.
4. Always connect the wet grinder to 15A plug socket.

### Washing Machines

Washing machines are used for washing and drying clothes. According to the operation methods, generally there are twin tub semiautomatic and single tub fully automatic washing machine.

#### Double tub semiautomatic washing machine

In double tub washing machines, two separate tubs are used for washing and drying. Washtub is used for both washing and rinsing. Spin tub or drier tub is used for drying and is mounted directly on a permanent split capacitor type induction motor. The time of wash/rinse operation can be controlled automatically with the help of a 'wash timer' switch. But after each wash/rinse operation wastewater has to be drain out and fresh water has to be filled with the tub manually.

After completing the rinsing, the clothes are puts into the drier tub manually. The wet clothes are rotated at high speed in this tub and the water particles from the wet clothes splashes out by centrifugal force. This water then drains out through the drain tube. The drying operation can be controlled automatically for a preset time by adjusting the drier timer switch. A lid switch is provided in this tub. So that when the lid of the spin tub is opened, lid switch contacts break the electrical circuit and soon dryer tub stops. This is to avoid danger of taking clothes from the fast rotating spin tub. Since the motor pulley is smaller than the impeller pulley, impeller speed is less than the motor speed.

#### Fully automatic washing machine

In fully automatic washing machine bothe washing and drying are done in the same tub. After loading the machine with clothes and as the switch is put ON, timer automatically changes its contacts for a series of operations such as filling water from the water supply line, washing by the rotation of impeller, draining out the waste water from the tub

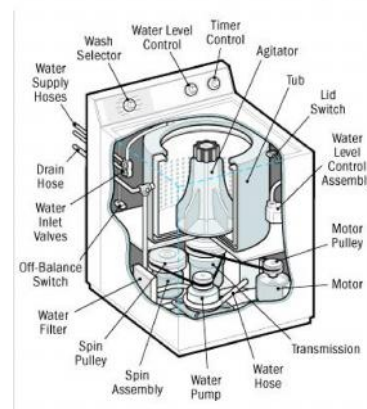

through the drain pipe and drying. During washing and rinsing only impeller rotates and during drying the whole spin tub rotates.

There is also a lid switch and a water level switch. By adjusting water level switch, the quantity of water filling each time can be adjusted. For controlling the operation of tub and impeller and for opening the drain valve, an electromagnet or solenoid valve is used.

### Servicing and Troubleshooting of Washing Machine

Trouble	Probable Cause	Remedies
1. Wash motor is not operating but "hums"	Impeller shaft stuck inside the bush bearing Worn bush bearing. Burnt motor winding. Defective capacitor. Thick, heavy or tight belt	Remove the belt, check clean and oil the pulley and shaft. Check after dismantling and replace if defective. Rewind if burnt Test the capacitor, and replace with same capacity Adjust the belt. If the belt is defective, use the belt of same thickness.
2. Water is leaking from the wash tub near the impeller shaft	Defective oil seal or worn bush bearing	Remove the pulley from the shaft, take out the plastic or metal case in which oil seal or bush bearing is fitted. Change the complete assembly or replace the bush bearing or oil seal refit carefully, fill the tub with water, operate the motor and check the leak.
3. Water leaks out from the washtub through Drain pipe.	Drain valve is dirty or torn	Remove the cover of drain valve and clean or change the rubber bellows.

Trouble	Probable Cause	Remedies
4. Water is not draining out, when drain valve knob is turned to 'drain' position	Darin valve cable is broken or defective	Repair or change the cable
5. Impeller operates with high noise	Worn bush bearing Loose screw of impeller pulley	Check and replace Check and tighten the screw
6. Impeller is operating only in one direction continuously	Wash timer is stuck and not changing the contact	Clean, repair or replace the timer
7. Impeller rotates slowly	Loose belt Burnt winding	Adjust the motor for correct belt tension or change belt. Dismantle the motor, check the windings, rewind if required.
8. Spin tub not working even no humming sound produced.	Lid switch not making contact Timer is not making contact	Open the panel plate and test by shorting the lid switch Test by shorting two wires from timer. If spin motor is working now timer is defective- repair or replace.
9. Spin motor hums when putting 'ON'	Defective capacitor Burnt motor winding. Worn motor bush bearings	Test the capacitor and change with same capacity Dismantle the motor, check the windings and rewind Change the bearings
10. Electric shock on the machine body	Bare live wire in contact with the machine body	Test for earth fault with series test lamp. Locate the fault and repair it.

### Precautions.

1. Do not operate on low voltages.

2. Maintain sufficient water level inside the tub.
3. Do not open the lid while the machine is operating.
4. Do not overload the machine.
5. Do not operate the machine without filling water inside the tub.
6. Do not put hard materials such as coins metal pieces e.t.c. inside the washing machine.

**Assessment activities**

1. Practical work on fault identification, repairing and servicing of common appliances.

## Unit-3 Engineering Graphics:

### Introduction

Engineering Graphics is the language of Engineers. The purpose of this unit is to give the basics of engineering sketching and drawing. We will treat "sketching" and "drawing" as one. "Sketching" generally means freehand drawing. "Drawing" usually means using drawing instruments, from compasses to computers to bring precision to the drawings.

### Learning Outcomes

- Understand the importance of engineering graphics
- Recognise the use of drawing instruments, standards, symbols etc.
- Appreciate the lettering, numbering, dimensioning.
- Recognise geometric construction & Scales.
- Understand the projections of points ,lines & planes
- Explain the principles of orthographic projection with simple sketches.
- Appreciate the sectional views of objects.
- Appreciate the auxiliary views of objects.
- Identify the pictorial drawings of various objects
- Sketch the orthographic views of simple objects from its pictorial drawing.
- Realize concept of development of surfaces like cylinder and pyramid.
- Familiarise computer aided drafting & Electrical Auto CAD.

### Concept Detailing

#### Importance of Engineering graphics

The knowledge of Engineering Graphics is useful to both scientist as well as Engineers. Engineering graphics is a set of rules and guidelines that help to create an engineering drawing. It is a graphical language that communicates ideas and information from one mind to another. One of the best ways to communicate one's ideas is through some form of picture or drawing. This is especially true for the engineer.

#### Drawing Instruments

Drawing Instruments are used to prepare drawings accurately and easily. The accuracy and quality of drawing depends on the accuracy and quality of drawing instruments. The following are the commonly used materials and tools in engineering drawing.

### Basic Tools and materials

- Drawing board, Drawing paper, pencil, eraser, Drawing pins/ tape, Clips, Duster.
- T-Square and Set Square, Mini drafter, Scales, Dividers and Protractor.
- Compass, French curves and Templates

#### T-SQUARE

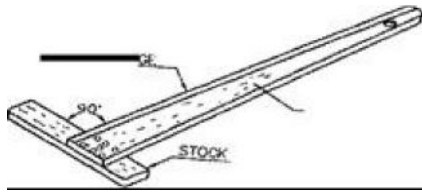

#### PROTRACTOR

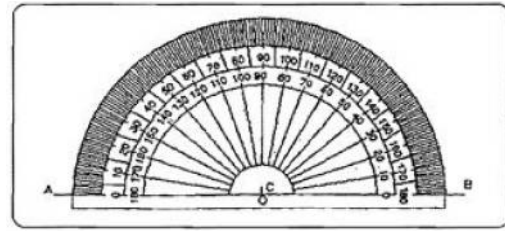

#### SET SQUARE

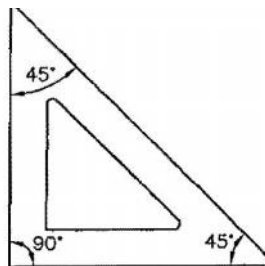

45° Set square

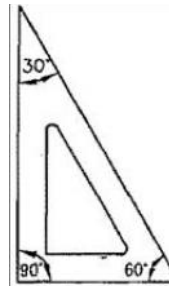

60° Set square

#### COMPASS

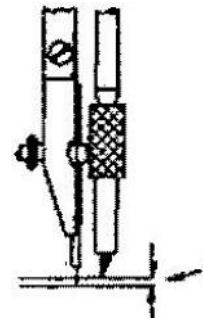
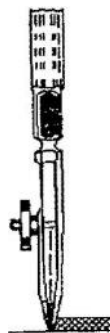
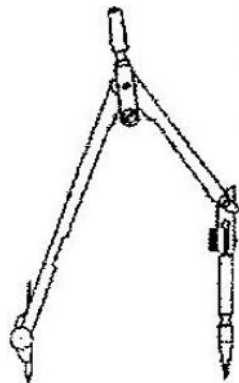

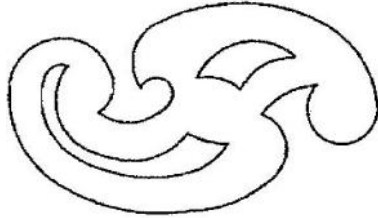
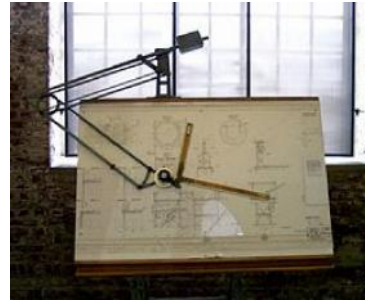

**FRENCH CURVE****Drafting machine**

A drafting machine is a device which is mounted to the drawing board. It has rulers whose angles can be precisely adjusted with a controlling mechanism. There are two main types of apparatus: an arm-type parallelogram apparatus based on a hinged arm; and a track-type apparatus which moves on a rail mounted to the top of the drawing board. Small drafting machines (mini drafters) are commonly used.

**Rulers**

Rulers also called Architect's scale used in technical drawing are usually made of polystyrene. It is available in two types according to the design of their edge as (1) Straight edge and grooved edge.

**Drawing sheet Dimensions**

SIZE (Designation)	Dimensions in mm
A0	841 X 1189
A1	594 X 841
A2	420 X 594
A3	297 X 420
A4	210 X 297

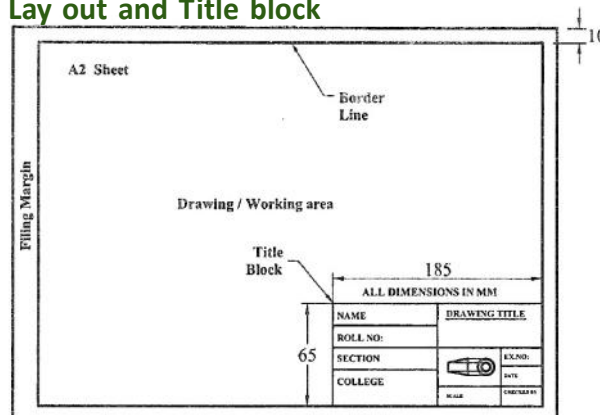
**Drawing sheet Lay out and Title block**

## BIS Codes relevant to Engineering Drawing

No	BIS/ISO Code	Area of Standardisation
1.	IS:9609-1983 from ISO: 3098/1-1974(E)	Lettering for Technical Drawings
2.	IS:10711-1983 from ISO: 5457-1980	Drawing sheets (Sizes and layouts etc)
3.	IS:10713-1983	Scales for use on Technical Drawing.
4.	IS:10714-1983 from ISO: 128-1982(E)	General principles of presentation of drawings-Lines
5.	IS:10718-1983 from ISO/DIS:129	Methods of Dimensioning and Tolerancing of Technical Drawing.
6.	IS:11664-1986	Folding of Drawing Sheets.
7.	IS:11665-1985	Technical Drawings - Title Blocks.
8.	IS:11669-1986	General principles of Dimensioning for Technical Drawing.

### Folding of drawing sheets

**Folding of Drawing Sheets**  
Following table illustrates the folding of various sizes of drawing sheet (A0, A1, A2, A3).

Sheet Size	Folding Diagram	Lengthwise Folding	Cross Folding
<b>A 0</b> 841 X 1189			
<b>A 1</b> 594 X 841			
<b>A 2</b> 420 X 594			
<b>A 3</b> 297 X 420			No cross folding

## Lettering and Dimensioning

Writing of titles, dimensions, notes and other important particulars on a drawing is called lettering. Lettering can be done in different ways such as hand lettering, mechanical lettering etc. Mechanical lettering can be done using typewriter or computer.

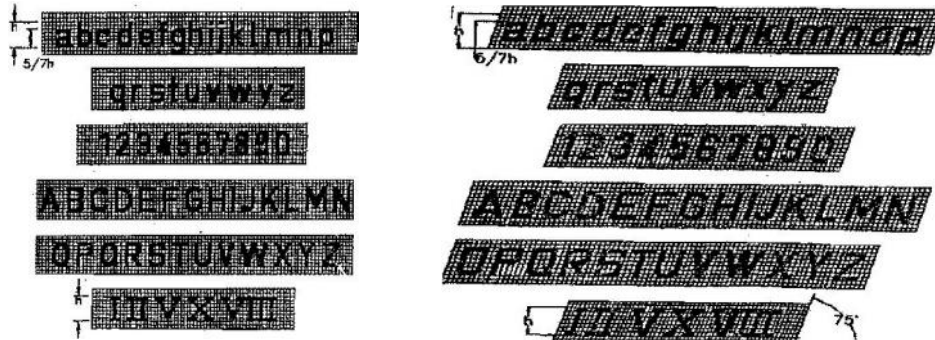

Dimension is a numerical value expressed in appropriate units of measurement and marked on a drawing with lines, symbols and notes. The dimension without any unit is considered in 'mm'. The elements of dimensioning are projection line or extension line, dimension line, leader line and arrowheads. Projection line is a thin, dark, solid line that extends from a point on the drawing to which a dimension refers. A dimension line is a thin line that shows where a measurement begins and where it ends. The dimension line should have a break in it for the dimension numbers. Dimension line should be at least 10mm from the lines of the drawing. Leader lines are thin lines drawn from a note or a dimension to the place where it applies. Arrowheads are used at the ends of the dimension lines. They show where a dimension begins and ends.

### Points To Be Considered In Dimensioning





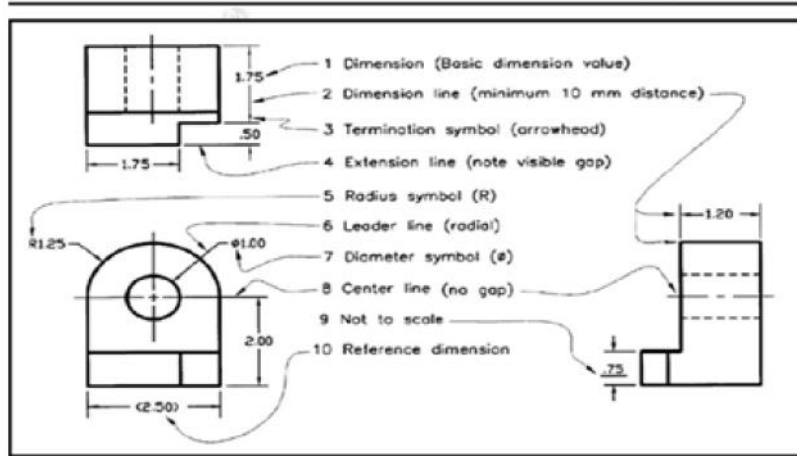

- Each drawing shall use the same unit for all dimensions.
- Long extension line should be avoided.
- Do not cross a dimension line with another line.
- Each feature of the object shall be dimensioned only once on a drawing.
- All dimensions which are necessary to define an object or component must be clearly marked on the drawing.
- Dimension lines are placed outside the drawings except in special cases where marking inside the drawing is readable.
- In general, dimensions should be placed outside the view outline.

## Dimension Basic Terminology



### LINES

In engineering drawing, different types of lines are used to describe different objects. The following are some of the commonly used lines.

Types of Line	Description	General application	Pencil Grade
	Continuous thick	Object lines, Visible outlines and Visible edges.	H
	Continuous thin	Dimension lines, Projection lines, Leader lines, Extension lines, Construction lines, Section lines, and Hatching lines	2H
	Dashed thin	Hidden outline and Hidden edges	H
	Chain thin	Centre lines and Lines of symmetry	2H
	Chain thin, thick at the ends	Cutting planes	2H & H
	Continuous thin (Freehand/wavy)	Irregular boundary lines and Short break lines	2H
	Continuous thin (Zigzag)	Long break lines	2H

Representing scales: The proportion between the drawing and the actual object can be represented by two ways as follows:

- a) Scale: - 1cm = 1m or 1cm=100cm or 1:100

- b) Representative Fraction: - (RF) =  $1/100$  (less than one) i.e. the ratio between the size of the drawing and the object.

There are three types of scales depending upon the proportion;

Reducing scale: When the dimensions on the drawing are smaller than the actual dimensions of the object. It is represented by the scale and RF as

Scale: -  $1\text{cm}=100\text{cm}$  or  $1:100$  and by  $\text{RF}=1/100$  (less than one)

Full scale: Sometimes the actual dimensions of the object will be adopted on the drawing then in that case it is represented by the scale and RF as

Scale: -  $1\text{cm} = 1\text{cm}$  or  $1:1$  and by  $\text{R.F.}=1/1$  (equal to one).

Enlarging scale: In some cases when the objects are very small like inside parts of a wrist watch, the dimensions adopted on the drawing will be bigger than the actual dimensions of the objects then in that case it is represented by scale and RF as

Scale: -  $10\text{cm}=1\text{cm}$  or  $10:1$  and by  $\text{R.F.}= 10/1$  (greater than one)

The scale or R.F of a drawing is given usually below the drawing.

The various types of scales used are

1. Plain scales
2. Diagonal scales
3. Vernier scales,
4. Comparative scales
5. Scale of chords.

## Geometrical Drawing

### Introduction

The drawing of object views involves plane geometric constructions. It is necessary to have a good knowledge of plane geometry. Preparation of engineering drawings involves number of geometrical constructions. Hence it is necessary to study geometrical drawing. Geometrical constructions relating to straight lines, circles, arcs of circles, Triangle, rectangle, square, regular polygons and conic sections are illustrated in this chapter.

### Point

A point represents a location in space or on a drawing and generally represented by a very small circle or a small dot.

### Line

A line is the shortest distance between two points.

**Types of lines :**STRAIGHT LINE PARALLEL LINES 

CURVED LINES

**To bisect a given straight line or an arc**

To bisect a given straight line or arc

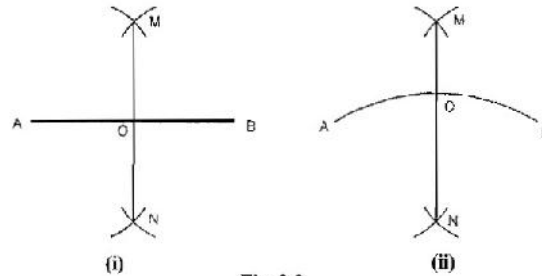
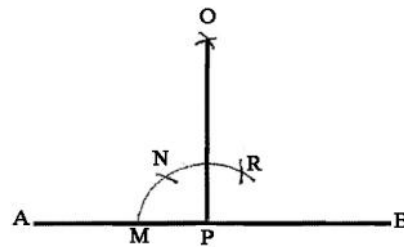

Fig. 2.2

- Let the straight line or arc be AB
- With A and B as centres and radius greater than half of AB, draw arcs intersecting each other at M and N respectively.
- Join M and N which bisect the line or arc.

**Drawing perpendicular**

1. Let P be the given point on a given line AB.
2. With P as centre, draw an arc cutting AB at M by taking any suitable radius.
3. With same radius, mark two equal divisions on the arc MN and NR respectively.
4. With centers N and R and of any suitable radius draw arcs to intersect at a point O. Draw a line OP through O and P, the line OP is the required perpendicular line.



### Dividing a Line Into Equal Parts

Dividing a line into number of equal parts by using dividers is not very accurate. A satisfactory method is given below.

1. If the line PQ is to be divided into six equal parts.
2. Draw a line PR inclined at any convenient acute angle to PQ.
3. Make six equal divisions along PR at any convenient length starting from P.
4. Join Q and 6. Draw lines parallel to Q6 through the division points 1, 2, 3, 4 and 5 cutting PQ at 1', 2', 3', 4', and 5'.
5. Points 1', 2', 3', 4', and 5' are the division points dividing PQ into equal parts.

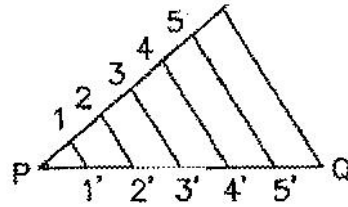

### Construction of Basic Geometric Shapes

#### Angles

An angle is the inclination between two intersecting lines.

#### Types of Angles

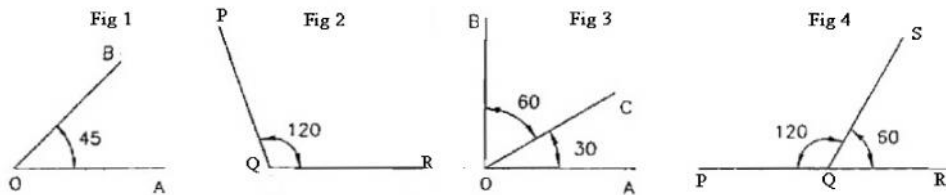

**Right angle:** Angle equal to  $90^\circ$  is called right angle. ( $\angle AOB$  in fig 3)

**Acute angle:** Angle less than  $90^\circ$  is called acute angle. (Fig 1)

**Obtuse angle:** Angle greater than  $90^\circ$  is called obtuse angle. (Fig 2)

**Complementary angle:** Angles which together forms  $90^\circ$  are called complementary angles. In fig. the AOC and BOC are complementary angles. The angle AOC is the complement angle of BOC and vice-versa. (Fig 3)

**Supplementary angles:** Those angles which together make  $180^\circ$  are called supplementary angles (Fig 4)

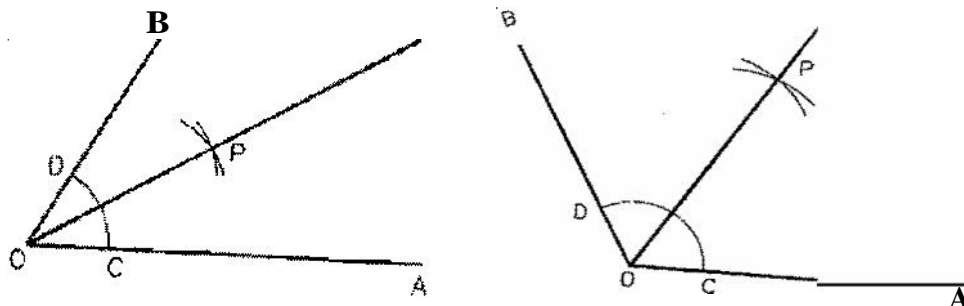
**Bisecting angle between two given lines:**

- Let the given angle be AOB between two given lines OA and OB
- With O as centre and with any convenient radius, draw an arc cutting OA at C and OB at D
- Now with C and D as centre and at any convenient radius draw arcs to intersect each other at P.
- Draw line through O and P which bisects the angle AOB.

**Triangles**

A triangle is a plane figure bounded by three straight lines containing three angles. The sum of three interior angles is  $180^\circ$ .

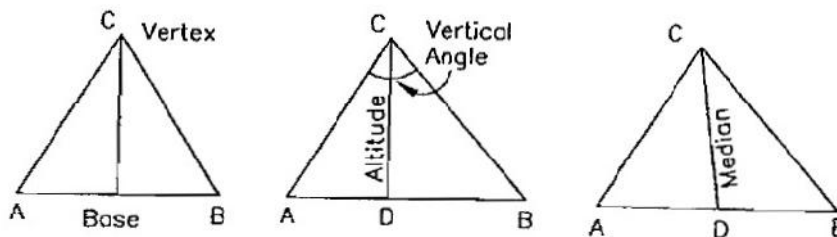

- The sum of all angles of a triangle is always  $180^\circ$ .
- The side on which it is supposed to stand is called its base and the angles at base are known as base angles.
- The point where the other two sides meet is called vertex and the angle at the vertex is called vertical angle.
- The line drawn from the vertex and perpendicular to the base or base produced if necessary is called an altitude.
- The line joining the angular point of a triangle to the middle point of the opposite of an angular point is called the median.



### Types of Triangle

- i) Equilateral triangle: It is triangle in which all the three sides are equal and the three angles are equal
- ii) Isosceles triangle: It is the triangle in which two sides as well as the angles opposite to them are equal.
- iii) Scalene triangle: It is the triangle in which no sides or angles are equal. The altitude may either be within or outside the triangle.
- iv) Right angled triangle: It is the triangle in which one angle is equal to  $90^\circ$  and the side opposite to it is called hypotenuse.
- v) Acute angled triangle: It is the triangle in which all the angles are acute.
- vi) Obtuse angled triangle: It is the triangle in which one of its angles is obtuse.

Drawing an equilateral triangle (given the length of one side)

Let AB be the given length of one side of an equilateral triangle.

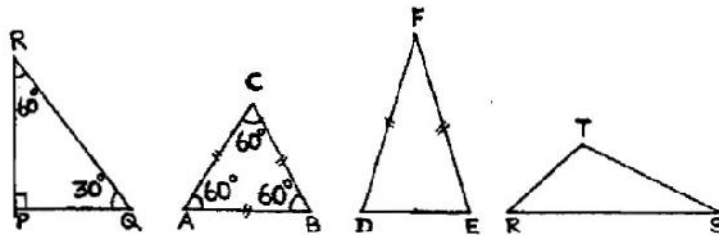

### Draw a triangle with T- square and set- square only

- Draw a line AB of given length by means of drafter
- Set the drafter at  $300^\circ$  - $600^\circ$  and draw a line through A making an angle of  $60^\circ$  with AB.
- Similarly through B draw a line BN making the same angle with BA thereby intersecting the first line at C.
- Join AC and BC, then ABC is the required equilateral triangle.

### With the help of compass

- Draw a line AB. With A and B as centres and radius equal to AB, draw arcs intersecting each other at C.
- Join AC and BC. Then ABC is the required equilateral triangle.

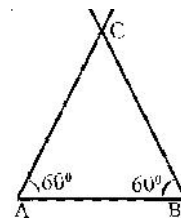

## Square

Square is the quadrilateral in which all the sides are equal and the angles are right angles.

Draw a square -given the length of one side

Let  $AB$  be the length of one side of the square.

### (a) With set square only

- Draw a line  $AB$  by means of a T-square, through  $A$  and  $B$  draw vertical lines  $AM$  and  $BN$ . Draw two lines  $AC$  and  $BD$  inclined at  $45^\circ$  to  $AB$  and  $BA$ , there by cutting  $BN$  at  $C$  and  $AM$  at  $D$ . Join  $C$  with  $D$ . Then  $ABCD$  is the required square.

### (b) With the help of compass

- Draw a given line  $AB$ . At  $A$  draw a line  $AM$  perpendicular to  $AB$  with  $A$  as centre and radius  $AB$ , draw an arc cutting  $AM$  at  $D$ . With  $B$  and  $D$  as centres and having same radius i.e.  $AB$ , draw arcs intersecting each other at  $C$ . Join  $BC$  and  $CD$ . Then  $ABCD$  is the required square.

### Q) Draw a circle inscribed in a square

- Draw a straight line  $AB$
- Draw vertical lines  $AM$  and  $BN$  from  $A$  and  $B$
- With  $A$  and  $B$  as centres draw arcs with radius  $AB$ , these arcs cut  $AM$  at  $C$  and  $BN$  at  $D$ . Join  $CD$
- Draw diagonals  $AD$  and  $BC$ . These two diagonals intersecting at  $O$ . Draw a vertical line from  $O$  to the midpoint of line  $AB$ . Draw circle with  $O$  as centre and radius  $OP$ .

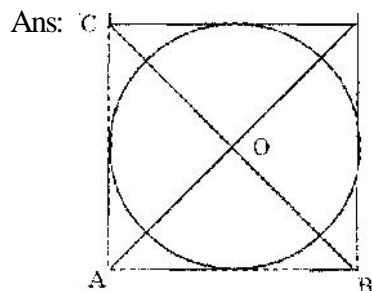

## Rectangle

Rectangle is the quadrilateral with the opposite sides is equal and all the angles are at right angles.

Draw a rectangle of length 60mm and breadth 30 mm as per the procedure

- Draw a straight line AB of length 60mm
- From A draw a vertical line AM.
- With A as centre and radius of 30mm draw an arc cutting AM at D.
- With D as centre and radius of 60mm draw an arc.
- With B as centre and radius of 30mm draw another arc.
- These two arcs intersect each other at C. Join BC and CD.
- Then rectangle ABCD is obtained.

### Polygons

A polygon may be defined as a plane figure bounded by straight lines. It is bounded by more than four straight lines and containing more than four angles.

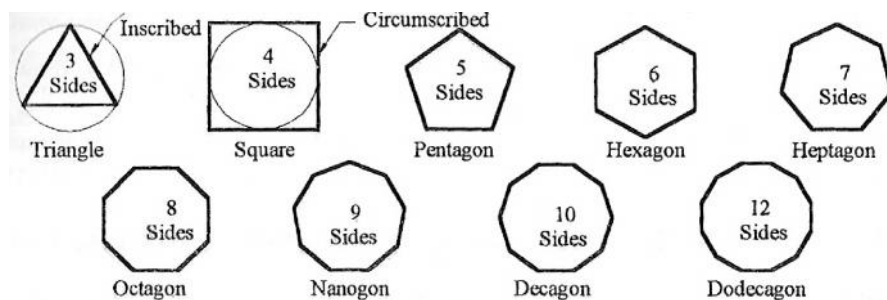

**Draw a pentagon of a given side (say 35mm)**

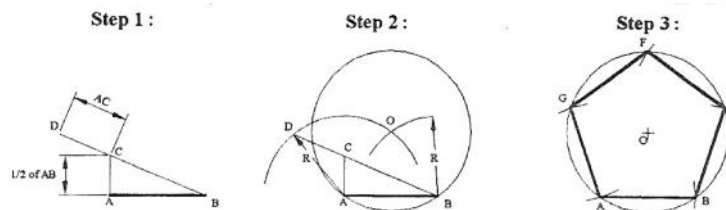

Construction of a Pentagon if length of side is given

#### Step 1

- Draw a line AB equal to 35mm.
- Draw perpendicular line AC equal to half of AB.
- Draw line BC and extend it to make line CD equal to AC.

#### Step 2

- With radius  $R=AD$  and points A & B as centres, draw intersecting arcs to locate point O. With the same radius and O as the centre, draw a circle.

**Step 3**

- With AB as a chord, locate points E, F & G. Join AG, GF, FE and EB. Then AGFEB is the required pentagon.

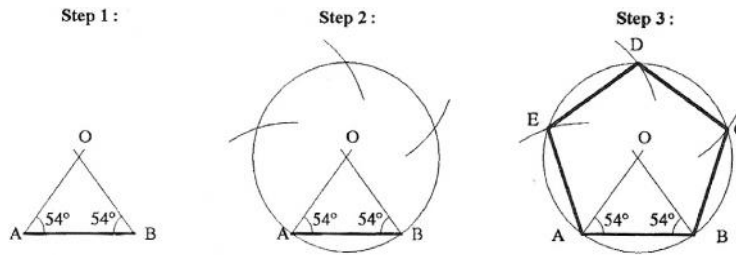
**METHOD 2****Step 1**

- Draw a line AB equal to 35mm.
- From the points A & B, draw  $54^\circ$  lines intersecting each other at O

**Step 2**

- Taking point O as centre and OA as radius, draw a circle. Set the compass at 35 mm and divide the circle starting from A.

**Step 3**

- Join all the cutting points to obtain the required pentagon.

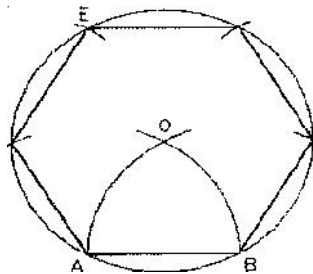
**HEXAGON**

Hexagon is that which has six sides and angles.

Draw a hexagon of given side (say 35mm)

- Draw a line AB equal to 35mm.
- With A and B as centres and radius of 35mm, draw arcs intersecting at O.
- With O as centre and having 35mm radius draws the segment of a circle.
- With AB as radius cut the segment at C, D, E and F.
- Join BC, CD, DE, EF and FA. Then ABCDEF is the required hexagon.

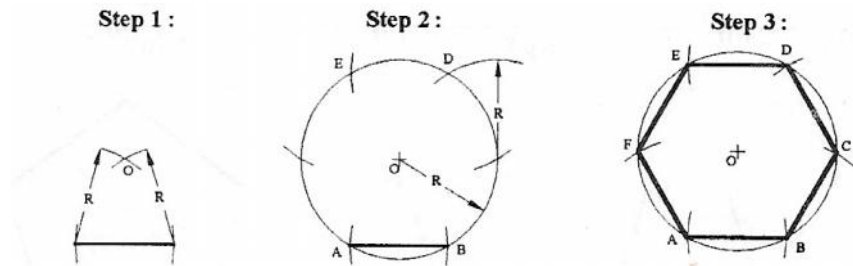
**METHOD 2****Step 1**

- Draw line AB of length 35mm. Taking A & B as centres and  $R=35\text{mm}$  as radius, draw arcs cutting each other at O.

**Step 2**

- With O as centre and  $R=35\text{mm}$  as radius, draw a circle. Set the compass at 35 mm and divide the circle into 6 parts.

**Step 3**

- Join all cutting points by the line segments, to obtain the required hexagon.

**CONIC SECTIONS**

Conic section is the curves obtained by the intersection of a right circular cone by a plane at different angles. Ellipse, parabola, and hyperbola are the curves thus obtained and hence are called the conic sections or conics.

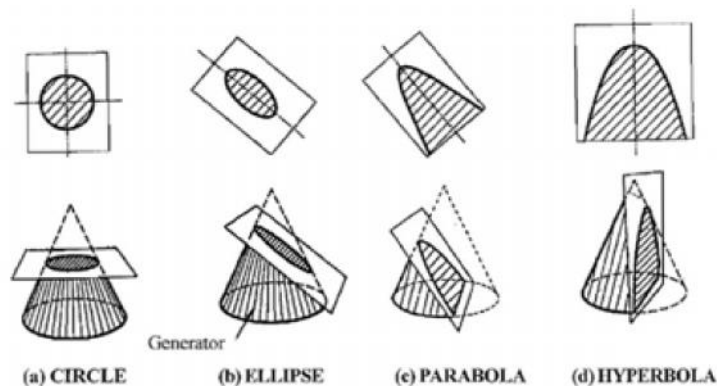
**ELLIPSE**

An ellipse is a plane curve that results from the intersection of a cone by a plane in a way that produces a closed curve. Circles are special cases of ellipses, obtained when the cutting plane is perpendicular to the axis. An ellipse is also the locus of all points of the plane whose distances to two fixed points add to the same constant.

Ellipses are closed curves and are the bounded case of the conic sections, the curves that result from the intersection of a circular cone and a plane that does not pass through its apex; the other two (open and unbounded) cases are parabolas and hyperbolas. Ellipses can also arise as images of a circle under parallel projection and some cases of perspective projection.

- Q) Draw an ellipse of major axis 80 mm and minor axis 50mm in concentric circles method

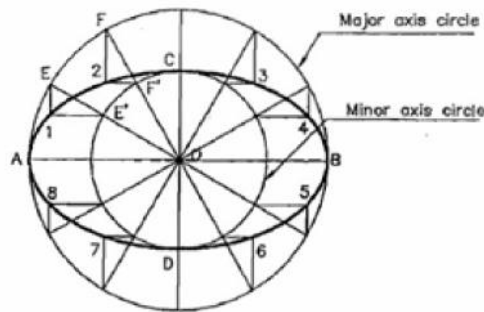

Ans:

- 1) Draw AB (80mm) and CD (50mm) the major and minor axes perpendicular to each other cutting at O.
- 2) With O as centre, draw two concentric circles of diameter 80 mm and 50mm as shown.
- 3) Draw radial lines OE',E, OF, F etc. at convenient angular intervals of say  $30^\circ$ .
- 4) From points E, F etc. on the major axis circle, draw lines perpendicular to the major axis AB. From points E', F' etc. on the minor axis circle, draw lines parallel to the major axis. The intersection of perpendicular and parallel lines from points on the same radial line will fix a point on the required ellipse.
- (5) Draw a graceful curve through these points to define the ellipse.

#### FOUR CENTRE METHOD

##### Step 1

- Draw major axis AB and minor axis CD for the respective lengths. Joint the points A and C. With centre as O and radius equal to OC, draw an arc which is intersecting OA at E. The point F is marked in such a way that CF is equal to AE.

**Step 2**

- Draw the perpendicular bisector of the line AF. This perpendicular line intersecting the major axis at G and minor axis at H. Mark other centres I and J such that  $OI = OG$  and  $OJ = OH$  are located.

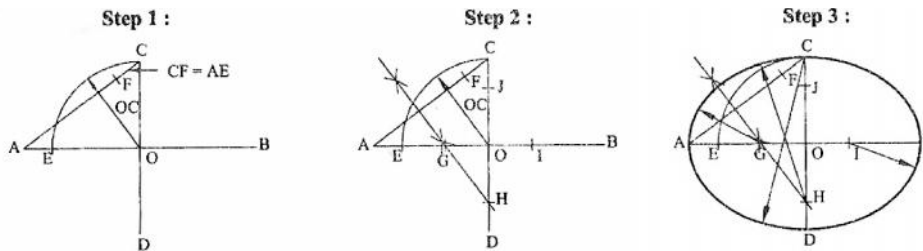

**Step 3**

- With G and I as centres, draw two arcs of radius GA and IB respectively. With H and J as centres, draw two arcs of radius HC, JD respectively. These four arcs meet tangentially to form the required ellipse

**PARABOLA**

The parabola is a conic section, the intersection of a right circular conical surface and a plane to a generating straight line of that surface. Given a point (the focus) and a corresponding line (the directrix) on the plane, the locus of points in that plane that are equidistant from them is a parabola.

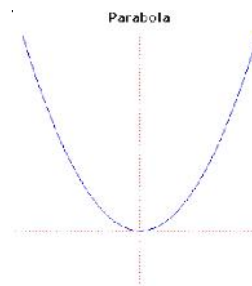

**PARALLELOGRAM METHOD**

**Step 1**

- Given the sizes of the enclosing rectangle, distances AB and AC, construct a parallelogram.

**Step 2**

- Divide AC into a number of equal parts. Divide AO into the same number of equal parts. Number the points as shown in figure.

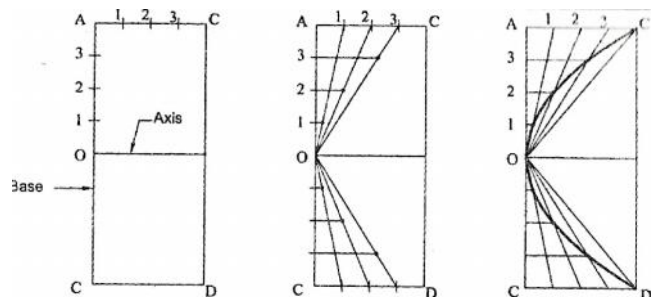

**Step 3**

- Draw a line from O to point 1 on AC. Draw a line parallel to the axis through point 1 on line AO. Mark intersecting point to the previous line O-1. The point of intersection is a point on the parabola.

**Step 4**

- Proceed in the same manner to find other points on the parabola.

**Step 5**

- Connect the points using an irregular curve to get the required parabola.

**HYPERBOLA**

The hyperbola is a plane curve obtained when the cutting plane is inclined to the axis at an angle smaller than the angle of the generator and it passes through the base.

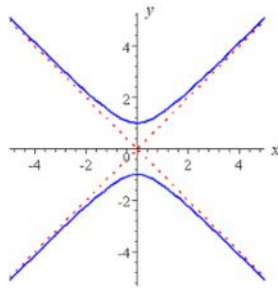
**SPECIAL CURVES****Involute**

The curve traced out by the end of a piece of string which is kept tight at one end and the other end when unwound from a triangle, square, circle or a regular polygon is called involute. It is used in designing gear tooth profiles and impeller of centrifugal pumps.

Involute of an equilateral triangle of side 'a'

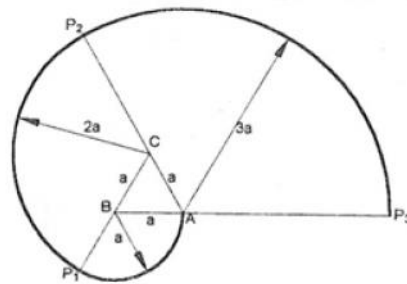
**Step 1**

- Draw the triangle ABC for the given side 'a'

**Step 2**

- With centre as B and radius as  $BA=a$ , draw an arc to intersect the extended CB line at  $P_1$ .



**Step 3**

- With centre as C and radius as  $CP_1 = 2a$ , draw an arc to intersect the extended AC line at  $P_2$ .

**Step 4**

- With centre as A and radius as  $AP_2 = 3a$ , draw an arc to intersect the extended BA line at  $P_3$ .

**Step 5**

- Draw a smooth curve through the points A,  $P_1$ ,  $P_2$ ,  $P_3$  to obtain the involute.

*Activity: Draw involute of an equilateral triangle of side 30mm.*

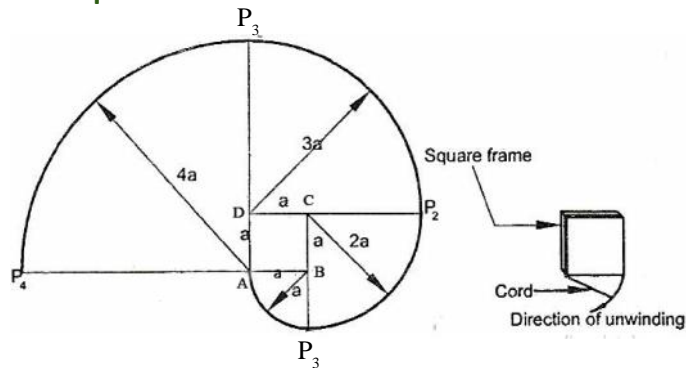
**Involute of a square of side 'a'****Step 1**

- Draw the square ABCD with side = 20mm

**Step 2**

- With centre as B and radius as  $AB = a$ , draw an arc to intersect the extended BC line at  $P_1$ .

**Step 3**

- With centre as C and radius as  $CP_1 = 2a$ , draw an arc to intersect the extended DC line at  $P_2$ .

**Step 4**

- With centre as D and radius as  $DP_2 = 3a$ , draw an arc to intersect the extended AD line at  $P_3$ .

**Step 5**

- With centre as A and radius as  $AP_3 = 4a$ , draw an arc to intersect the extended AB line at  $P_4$ .

**Step 6**

- Draw a smooth curve through the points A, P<sub>1</sub>, P<sub>2</sub>, P<sub>3</sub>, P<sub>4</sub> to obtain the involute.

**Helix**

Helix is a curve generated by a point moving on the surface of a cylinder or a cone in the circumferential direction at a constant angular velocity in the axial direction at a uniform rate. There are 2 types of helices. Such as

1. Cylindrical helix
2. Conical helix

**PRINCIPLES OF PROJECTIONS**

If straight lines are drawn from various points on the contour of an object to meet a plane, the object is said to be projected on that plane. The figure formed by joining, in correct sequence, the points at which these lines meet the plane, is called the projection of the object. The lines from the object to the plane are called projectors.

**TYPES OF PROJECTIONS**

The projections are classified according to the method of taking the projection on the plane. A classification of projection is shown below:

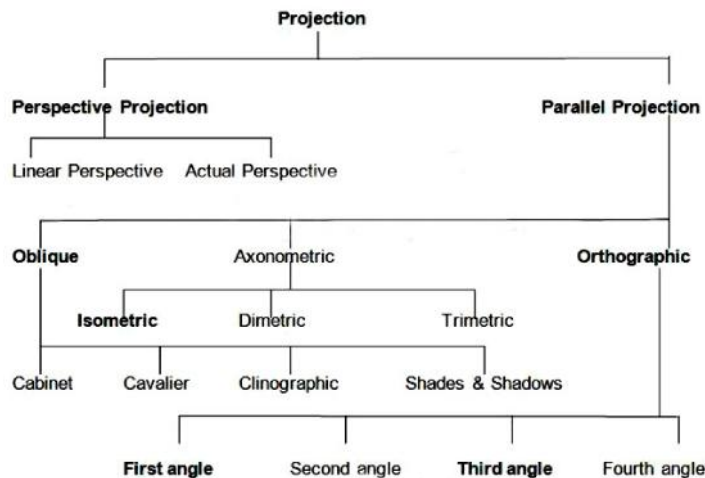
**ORTHOGRAPHIC PROJECTION**

Orthographic projection is one method of projection used in engineering drawing in which the objects are projected on imaginary planes. This means we make the object become 2D. The difference between Orthographic Projection and any other drawing method is that we use several 2D views of the object instead of a single view.

In orthographic projection the object is placed at infinite distance from the observer. The image formed on the picture plane is orthographic projection. The word orthographic means to draw at right angles.

### CREATING AN ORTHOGRAPHIC PROJECTION

1. The following steps will take you through the creation of an orthographic projection.
2. Choose a front view. This is the view that shows the most about the object.
3. Decide how many views are needed to completely describe the object.
4. Draw the visible features of the front view.
5. Draw projectors of the front view horizontally and vertically in order to create the boundaries for the top and right side views.
6. Draw the top view. Use the vertical projectors to fill in the visible and hidden features.
7. Project from the top view back to the front view. Use the vertical projectors to fill in any missing visible or hidden features in the front view.
8. Draw a 45° projector of the upper right corner that encloses the front view.
9. From the top view, draw projectors over to the 45° line and down in order to create the boundaries of the right side view.
10. Draw the right side view.

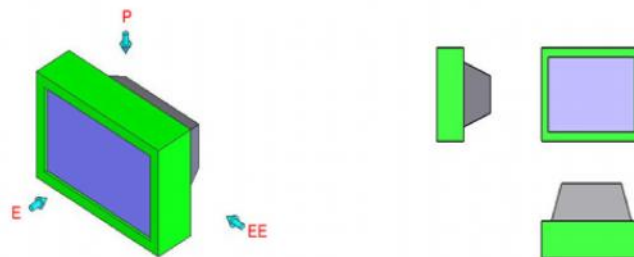
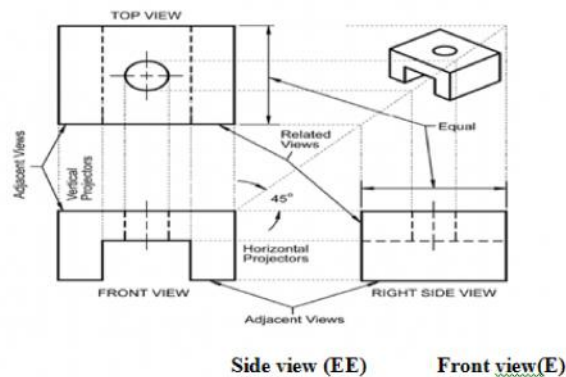

P- PLAN, E- ELEVATION, EE- SIDE VIEW Top view (P)

## Basics of Orthographic Projection

The planes of projection are extended beyond the line of intersection to form four quadrants. The position of objects in any one these four quadrants are as follows

1. First quadrant-HP in front of vertical plane(VP)
2. Second quadrant-Above HP and behind VP
3. Third quadrant-Below HP and behind VP
4. Fourth quadrant; Below HP and in front of VP

### ORTHOGRAPHIC VIEWS

Orthographic views are obtained from orthographic projection. The front, top and side views are called as orthographic views. In orthographic projection, the picture planes are called as planes of projection and the perpendicular line are called as project lines or projectors. When we draw an Orthographic view of the front of an object it is called ELEVATION. When we draw an Orthographic view of the top of an object it is called PLAN.

The six principle views

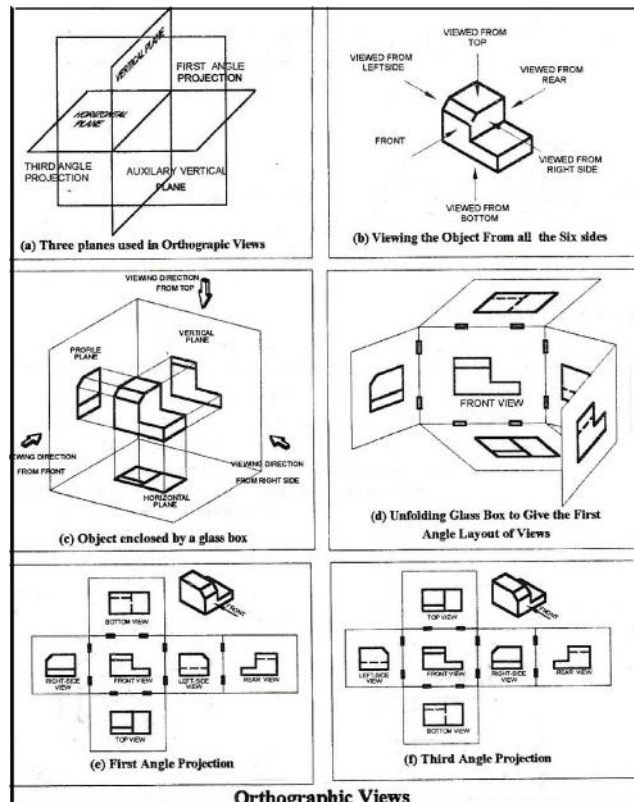
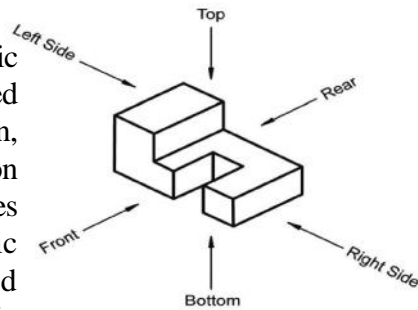

## TYPES OF ORTHOGRAPHIC PROJECTION



Usually there are 4 types of orthographic projections

- 1) First angle projection
- 2) Second angle projection
- 3) Third angle projection
- 4) Fourth angle projection

In engineering drawing we prefer only the first angle projection.

### DIFFERENCE BETWEEN FIRST ANGLE AND THIRD ANGLE PROJECTION

First angle projection	Third angle projection
The object is placed in the first quadrant	The object is placed in the third quadrant
The object lies between the observer and the plane of projection.	The plane of projection lies between the observer and the object
In this method, when the views are drawn in their relative position, the plan comes below the elevation. The left side view is drawn in the right side of elevation.	In this method, when the views are drawn in their relative position, the plan comes above the elevation. The left side view is drawn in the left side of elevation.
The plane of projection is assumed to be non transparent	The plane of projection is assumed to be transparent
Normally this projection is used in India and British countries	Normally this projection is used in USA

Projection	Symbol
First angle	
Third angle	

#### Example

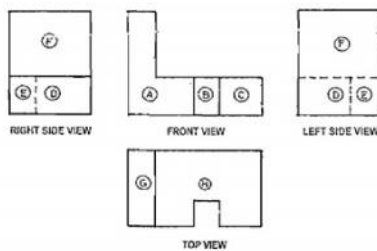

## ISOMETRIC PROJECTION

Isometric projection is a method for visually representing three-dimensional objects in two dimensions in technical and engineering drawings. It is an axonometric projection in which the three coordinate axes appear equally foreshortened and the angle between any two of them is 120 degrees.

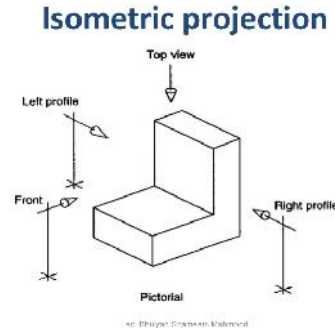

Isometric scale is used to measure the foreshortened length of dimensions of any object to draw the isometric projection. The steps of construction of isometric scale are given below

- (i) Draw a horizontal line PQ.
- (ii) Draw the true lengths on a line PM inclined at  $45^\circ$  to the horizontal line (say up to 70 mm)
- (iii) Draw another line PA at  $30^\circ$  to the horizontal line.
- (iv) Draw the vertical projection of all the points of true length from PM to PA.
- (v) Complete the scale with the details as shown in the figure. The lengths shown at the line PA are the isometric lengths to be used to draw the isometric projection.

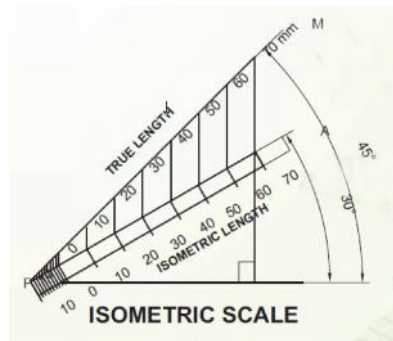

## ISOMETRIC DRAWING

Exercise: Draw the isometric drawing of a rectangular prism of base 30 mm x 15 mm and the height 50 mm

- o Draw the three isometric axes through point 'A'.
- o Mark  $AB = 15$  mm,  $AD = 30$  mm and  $AH = 50$  mm representing the three sides of prism.

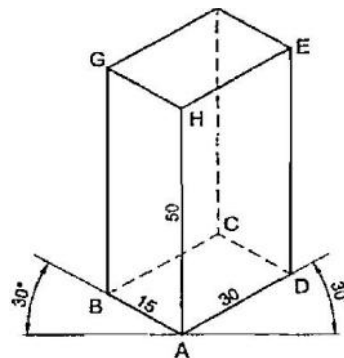

- o Draw two vertical lines parallel to the line AH through points B and D.
- o Similarly draw two more lines parallel to AB and AD through point H.
- o Mark G and E the intersecting points.
- o Draw lines parallel to GH and HE through points G and E intersecting point is F.
- o Draw lines parallel to AB & AD through points D and B respectively intersecting at C.
- o Join CB & CD with dash lines.
- o Join F and C also with dash lines.
- o Rub off the construction lines and complete the prism.

*Draw the isometric projection of a cube of side 50mm*

### FREEHAND SKETCHING

Freehand sketch is a drawing made without the help of drawing instruments.

The important uses of freehand sketching are:

- It is used to convey the thoughts and ideas to the workers.
- It is used to present the ideas of the designer to the management.
- It is used for showing different layouts of the drawing.
- It is used in the production of temporary fixtures.
- It is also used to convey information regarding repair or modification needed in an existing structure or machine.

### Comparison Between Free Hand Sketching And Instrumental Drawing

Free hand sketching	Instrumental drawing
Drawing made without the use of drawing instrument	Drawing made with the use of drawing instrument
It is not drawn to actual scale	It is drawn to actual scale
It is not a perfect drawing	It is a perfect drawing with uniform line thickness
It is used for temporary figures/fixtures	It gives exact details of object to be manufactured

**EXAMPLE:** Sketch by free hand, the isometric view of the objects shown in figure. The dimensioning also is to be marked by freehand

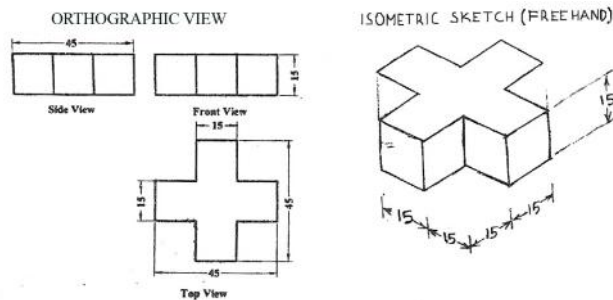

### AUXILIARY VIEW

If a surface of an object is inclined to any of the planes of projection, the view of the surface of that plane will not show its true shape and size. To overcome this difficulty a view of the inclined surface is projected on an imaginary plane parallel to this inclined surface. This imaginary plane is called Auxiliary plane and the view obtained on it is called Auxiliary view.

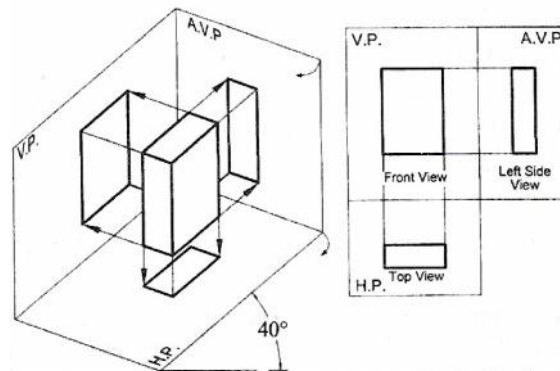

### SECTIONAL VIEWS

Interior details of an object cannot be shown on principal exterior views. In such cases an imaginary cutting (sectioning) plane may be used to cut through the object so that the portion in front of the plane can be imagined to be removed so as to expose inner details.

The sectional view shows and elaborates the internal construction of a machine. The view can be the section of either Top view, Front view or Side view. Actually the sectional view is an "anatomy" study of a machine. Designers use these view to analyse the constructional details and to modify the design of a machine. They are the projected views (either Auxiliary or Orthographic) which show a cross section



of the source object along the specified cut plane. There are different types of sectional views such as (1) Full Sectional view, (2) Half Sectional view, (3) Partial/ Broken Sectional view, (4) Revolved Sectional view, (5) Offset sectional view and (6) Removed sectional view.

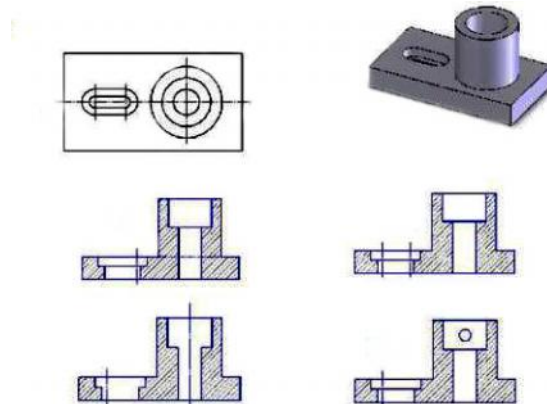

### DEVELOPMENT OF SURFACES

The knowledge of development of surfaces is used in the engineering applications such as sheet metal works, automobile body building, packing industry etc. The surface of an object which are opened out and laid on a flat plane is called the development of surfaces of that object.

### DEVELOPMENT OF CYLINDER

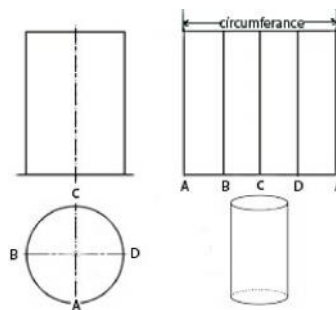

Cylinder is wrapped around a paper. When the paper is opened, it is rectangle in size.

Length = circumference of cylinder

Breadth = Height of cylinder

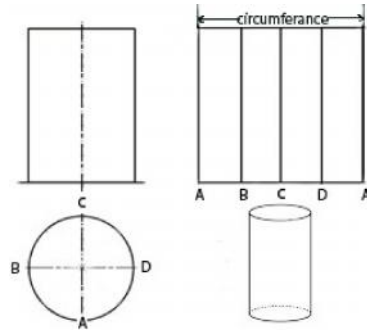

*Generally, parallel line method is used for development of cubes, prisms, cylinder etc.*

### DEVELOPMENT OF HEXAGONAL PYRAMID (Radial line method)

Pyramid is developed as follows:

Draw an arc of radius OA -. Divide the arc into 6 equal sectors so that each sector is equal to distance x

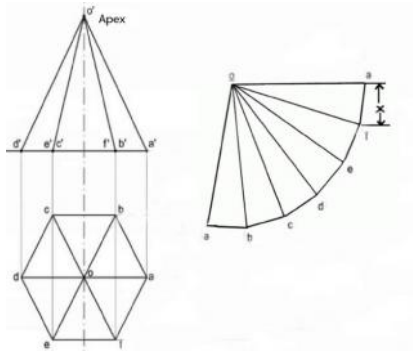

*Every line on the development must be the true length of the corresponding edge on the surface*

### T. E Questions

1. Draw a bisecting line for a given straight line AB of length 120 mm
2. Draw a perpendicular line to a given straight line AB of length 110mm from a given point O , AO = 40mm
3. Divide the given straight line AB length of 120mm into 7 equal parts.
4. Draw the involute of a square of 45mm side.
5. Compare free hand sketching and instrumental drawing?

### COMPUTER AIDED DRAFTING

#### INTRODUCTION

CAD is the acronym for Computer Aided Design. It is an interactive drawing system designed to permit a user to construct or edit a drawing on a graphics display screen. A CAD system is a combination of hardware and software that enables engineers to design structures, wiring installations etc. The hardware includes all the physical components of a computer such as C.P.U, input devices, output devices, secondary

storage devices and display unit. The software is application software designed for specific purpose. It is a design package commonly used in areas like mechanical, architectural, civil and electrical drawing. It allows an engineer to view a design from any angle with the push of a button and to zoom in or out for close ups and long distance views. It is very suitable for repetitive and very fast documentation.

CAD will be linked to CAM (Computer Aided Manufacture) whenever possible. Printed Circuit Boards can be designed on CAD and manufactured on CAM.

AutoCAD is flexible and drawings can be drawn quickly. Future modifications could be done easily. It offers better drawing visibility. Simulations of models can be done and testing of desired components and further alterations/improvements is possible. Some of the graphics packages are Auto CAD, Uni graphics, CATIA, NASTRAN etc. In this unit we are dealing with Auto CAD.

### **STARTING TO USE CAD**

The first step to use CAD is installing the required Auto CAD software in the computer. Then open this software package by double clicking on it. Then the startup dialogue box appears. It contains 3 options such as 'creating new drawing, open drawings and symbol libraries'. To exit from Auto CAD click on Exit.

CAD software is used to increase the productivity of the designer, improve the quality of design, improve communications through documentation, and to create a database for manufacturing. CAD output is often in the form of electronic files for print, machining, or other manufacturing operations.

### **ELECTRICAL AUTO CAD**

We use AutoCAD Electrical to draw power single line diagrams, motor control circuit schematics, switchboard general arrangements, and so on. By using Electrical Auto CAD

- You can design electrical symbols
- You can draw ordering lists & write texts
- You can place relay coils and contactors
- You can draw all the schematic diagrams you need

### **The powers of Electrical CAD software**

When you are producing the electrical documentation, you need distinctly other types of intelligent functions.

You need functions such as:

- Automatic update of parts lists and connection lists
- Automatic wire numbering
- Support of electrical standards
- Signal references between pages
- Reference designations

- Automatic drawing of connecting lines.
- Easy copying in and between projects
- References between symbols
- Automatically generated graphical cable and terminal plans
- The ability to create and send ordering files automatically

If you do business in other countries, you also need automatic translation of texts in drawings, and the ability to specify which types of texts to translate.

### Component databases

In electrical CAD software the symbols in the diagrams can be intelligent. This means that they can contain an article number for the component they represent - and even more important: the electrical connection points of the components can be identified and handled intelligent by the software. Being able to attach these types of information to a component, it enables the software to update all kinds of lists automatically.

ACTIVITY: Create a light and fan circuit using AutoCAD by seeing the figure below

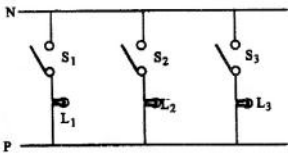

Before creating drawing Set layer and limits for the sheet.

**Command** : limits ↵  
Specify lower leftcorner or[ON/OFF] <0.00,0.00> : ↵  
Specify upper right corner<12.00, 9.00> : 200, 297  
**Command** : Z(Zoom) ↵  
[All/Centre/Dynamic/Extents/Previous/Scale/Window]<real time> : All  
Now the limits : get -set  
**Command** : La(layer) ↵

A dialog box will get open

**Create new layer**

Name : symbol  
colour : yellow  
linetype : 0.30 mm

**Create new layer**

Name : wiring  
colour : Red  
lineweight : 0.35 mm

Create symbol such as switch, lamp.

After creating these symbol set in layer symbol and block it.

**Command** : wblock ↵

A dialog box get open is your AutoCAD screen.

Under Wblock : Name of the object  
E&IWS: For oneway switch  
E&L : For electric light

After these object get block save there.

**Command** : l(line) ↵  
Specify first point : Pick a point on screen by ↵  
Specify second point or[Undo]: 80 right click ↵  
Set this line in layer

**Command** : Co(copy) ↵  
 Select objects : Pick the line right click  
 Specify back point or displacement : pick an one edge of line as base point.  
 Specify second point of displacement : 50 ↵

**Create vertical line**

**Command** : l(line) ↵  
 Specify first point : Pick a point on line A  
 Specify next point or[Undo] : 1 ↵

**Command** : Co(copy) ↵  
 Select objects : Pick the vertical line  
 Specify back point or displacement : Pick one edge of vertical line  
 Specify second point of displacement : 2 ↵

**Command** : copy ↵  
 Select objects : Pick the copied vertical line  
 Specify base point or displacement : Pick one edge of the copied vertical line  
 Specify second point of displacement : 2 ↵  
 Do the same process for other copying process too.  
**Command** : Insert

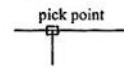
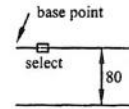

A menu box get open in that click browse select the black name here. Insert wherever you want. Do this same insert process for the remaining drawing also. Join lines wherever all you need to correct. Thus the 2D wiring diagram is created successfully.

*Source : Engineering Graphics Laboratory by VRB Publications*

## **LIST OF PRACTICAL ACTIVITIES - MODULE 4**

1. Fault finding in an AC motor.
2. Rewinding of single phase AC motors.
3. Wire up a single phase induction motor with DOL starter.
4. Identification of parts, Fault identification & repairing of Non automatic Electric Iron.
5. Identification of parts, Fault identification & repairing of Automatic Electric Iron.
6. Identification of parts, Fault locating , repairing & installation of Ceiling fan
7. Identification of parts, Fault identification & repairing of Wall mounted/pedestal fans.
8. Identification of parts, Fault identification & repairing of Electric Mixer.
9. Identification of parts, Fault identification & repairing of Wet Grinder.
10. Identification of parts, Fault identification & repairing of Washing Machine.
11. Servicing /trouble shooting & installation of water pump.
12. Practice geometrical construction.
13. Practice orthographic projection.
14. Sketch orthographic views of simple objects.
15. Practice Electrical Auto CAD.

## REFERENCES

- Solanki, Chetan Singh (2009) Solar Photo Voltaics- Fundamentals, Technologies and Applications .Prentice Hall of India pvt. Ltd. Third Edition.
- ChetansinghSolanki (2015) Solar Photovoltaic Technology and Systems. . Prentice Hall of India pvt. Ltd. Eastern Economy Edition.
- Sean White, Solar PV Engineering and Installation, Routledge Publication, First Edition (2015)
- V Ramesh Babu, R samyuktha, M. Manirathnam& S. Madhavan, Engineering Graphics Laboratory V.R.B Publishers Pvt. Ltd. First Edition (2007)
- K.C.John, Engineering Graphics for Degree, Eastern Economy Edition.
- K.B. Bhatia (2014) Study of Electrical appliance and Devices. Khanna Publishers. K P Anwer (2013) Domestic Appliances Servicing. Scholar Institute Publications, Thalassery.
- P I Varghese Engineering Graphics. VIP Publishers
- CBSE A Text book on Engineering Graphics (Class XII)
- S.P Sukhatme& J K Nayak Solar Energy -Principles of Thermal collection and storage, McGraw Hill companies, Third Edition
- G.K. Mithal (2006) Text book of Electrical Engineering.G.K.Publications
- B.L. Thereja,A.K.Theraja- Electrical Technology Vol.1 and 2, (2013), S chand publications.
- M.L. Anwani,Basic Electrical Engineering,(3rd Edition), DhanpatRai Publications.
- V. K. Mehta,Rohith Mehta(2014) Principles of Electronics, S Chand Publications
- Harish C Roy,(2013) Power Electronics, Umesh Publications
- AchuthSankar S Nair &K.Madanan(2006) Electronics- Basic Principles, State of language,Kerala
- N NBhargava, D C Kulshreshta, S C Gupta(2006) Basic Electronics & Linear circuits, Tata Mac Grawhil Publications.
- Prof. Sham Tickoo ,Auto CAD Electrical 2010 for Electrical Control Designers, Tickoo-CADCIM Series.