

EDUMATE

XII

PHYSICS



**Government of Kerala
DEPARTMENT OF EDUCATION**

**State Council of Educational Research and Training (SCERT), Kerala
2017**

Prepared by:

State Council of Educational
Research & Training (SCERT)
Poojappura, Thiruvananthapuram -12,
Kerala. E-mail:scertkerala@gmail.com

Type setting by:

SCERT Computer Lab.

©

Government of Kerala
Education Department
2017

Foreword

As part of the comprehensive revision of curriculum from pre-primary to the Higher Secondary sector, new textbooks have been developed for Std. XI and Std XII during the years 2014 -15 and 2015-16 respectively. Evaluation activities should go hand in hand with the new curriculum. Real learning takes place by constructing knowledge through various learning processes.

In a constructive classroom, learners have opportunities to engage in a number of activities in which a range of attributes can be developed. The same activities provide the learner with scope for assessing development of these attributes. Hence there has been a shift from assessing only the products of learning to the process of learning. Anyhow it is to be noted that term end assessment is a part of continuous and comprehensive evaluation.

The main objective of this book is to help the learners to face the public examination with confidence. In this context, questions from all chapters of each subject of Std. XII have been developed along with the scoring indicators. Hope that this question bank titled “Edumate” will be helpful to learners as well as teachers.

Your comments and suggestions are welcome and will assist us in improving the content of this book.

Wish you all the best.

Dr. J. Prasad
Director

Contents

Units

- 1 Electric Charges and Fields
- 2 Electrostatic Potentials and Capacitors
- 3 Current Electricity
- 4 Moving Charges and Magnetism
- 5 Magnetism and Matter
- 6 Electromagnetic Induction
- 7 Alternating Current
- 8 Electromagnetic Waves
- 9 Ray Optics and Optical Instruments
- 10 Wave Optics
- 11 Dual Nature of Matter and Radiation
- 12 Atoms
- 13 Nuclei
- 14 Semiconductor Electronics:
Materials, Devices and Simple Circuits
- 15 Communication Systems

Sample Question Papers with answerkey

EDUMATE

XII

PHYSICS



Government of Kerala
DEPARTMENT OF EDUCATION

State Council of Educational Research and Training (SCERT), Kerala
2017

Prepared by:

State Council of Educational
Research & Training (SCERT)
Poojappura, Thiruvananthapuram -12,
Kerala. E-mail:scertkerala@gmail.com

Type setting by:

SCERT Computer Lab.

©

Government of Kerala
Education Department
2017

Foreword

As part of the comprehensive revision of curriculum from pre-primary to the Higher Secondary sector, new textbooks have been developed for Std. XI and Std XII during the years 2014 -15 and 2015-16 respectively. Evaluation activities should go hand in hand with the new curriculum. Real learning takes place by constructing knowledge through various learning processes.

In a constructive classroom, learners have opportunities to engage in a number of activities in which a range of attributes can be developed. The same activities provide the learner with scope for assessing development of these attributes. Hence there has been a shift from assessing only the products of learning to the process of learning. Anyhow it is to be noted that term end assessment is a part of continuous and comprehensive evaluation.

The main objective of this book is to help the learners to face the public examination with confidence. In this context, questions from all chapters of each subject of Std. XII have been developed along with the scoring indicators. Hope that this question bank titled “Edumate” will be helpful to learners as well as teachers.

Your comments and suggestions are welcome and will assist us in improving the content of this book.

Wish you all the best.

Dr. J. Prasad
Director

Contents

Units

- 1 Electric Charges and Fields
- 2 Electrostatic Potentials and Capacitors
- 3 Current Electricity
- 4 Moving Charges and Magnetism
- 5 Magnetism and Matter
- 6 Electromagnetic Induction
- 7 Alternating Current
- 8 Electromagnetic Waves
- 9 Ray Optics and Optical Instruments
- 10 Wave Optics
- 11 Dual Nature of Matter and Radiation
- 12 Atoms
- 13 Nuclei
- 14 Semiconductor Electronics:
Materials, Devices and Simple Circuits
- 15 Communication Systems

Sample Question Papers with answerkey

ELECTROSTATIC CHARGES AND FIELDS

Q1

LO : 1.4

Question Text

There are two types of charges namely positive and negative.

- List any two basic properties of electric charge. (1)
- Can a body have a charge of $0.8 \times 10^{-19} \text{C}$? Which basic property of electric charge is the reason for your answer? (1)
- Name the basic property of electric charge that you can see in the equation

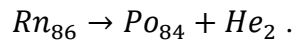

(1)

Scoring indicators

- Quantization of electric charge.
Conservation of electric charge.
- No. Quantization
- Conservation of electric charge.

Q2

LO : 1.5

Question Text

In electrostatics, Electric charge is a feature of particles like protons, electrons etc that decides the force of interaction among them.

- Write the name of the law that is used to measure the above force of interaction. (1)
- Express the above law in vector form. (1)
- Two charged spheres when placed in air attract with a force F . Keeping the distance between the charges constant, the spheres are immersed in a liquid of relative permittivity K . Then the spheres will
 - attract with a force KF
 - repel with a force KF
 - attract with a force F/K
 - repel with a force F/K (1)
- Two small aluminum spheres are separated by 80 cm. How many electrons are to be transferred from one sphere to the other so that they attract with a force of 10^4 N . (3)

Scoring indicators

- Coulomb's law in electrostatics

$$b) \vec{F} = \frac{1}{4\pi\epsilon_0} \times \frac{q_1 q_2}{r^2} \hat{r}$$

- c) attract with a force F/K
 d) If n electrons are transferred, charge on each sphere $Q = ne$

$$F = \frac{1}{4\pi\epsilon_0} \times \frac{(ne)^2}{r^2}$$

$$n^2 = \frac{Fr^2}{9 \times 10^9 \times e^2} = \frac{10^4 \times 0.8^2}{9 \times 10^9 \times (1.6 \times 10^{-19})^2} = 2.77 \times 10^{31}$$

$$n = 5.27 \times 10^{15}$$

Q3

LO : 1.7, 1.9

Question Text

Electric field is the region where an electric charge experiences a force and is visualized using the concept of electric field lines.

- a) What is the SI unit of intensity of electric field? (1)
 b) “In a uniform electric field charges of different magnitude experience the same force”. State whether this statement is true or false. (1)

- c) Two identical metallic plates are charged with equal amount of charges as shown in the figure. Draw electric field lines representing the field between the plates. (2)

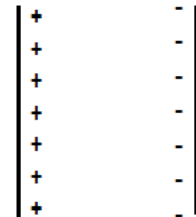

- d) An uncharged metal hollow sphere is now placed between the plates as shown in the figure. Redraw the field lines (2)

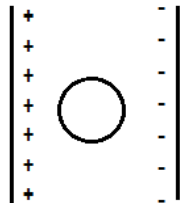

Scoring Indicators :

- a) NC^{-1} or Vm^{-1}
 b) False
 c)

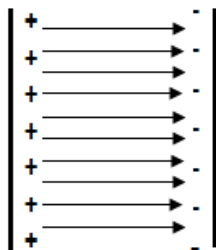

d)

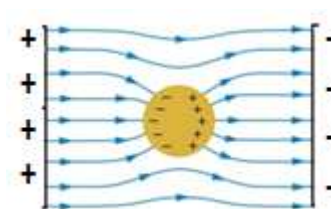

Q4

LO : 1.7, 1.8

Question Text

Intensity of electric field is a vector quantity.

- a) Define intensity of electric field at a point. (1)
- b) Two small spheres A and B carrying charges $2 \mu\text{C}$ and $6\mu\text{C}$ respectively are separated by a fixed distance. Intensity of electric field at the location of B due to A is E. Intensity of electric field at the location of A due to B is
 (i) E (ii) 3E (iii) 6E (iv) 12E (1)
- c) Two point charges $+4 \text{ nC}$ and $+5 \text{ nC}$ are placed at $x=0.2 \text{ m}$ and $x=-0.3 \text{ m}$ respectively along the x axis. Find the magnitude and direction of intensity of electric field at the origin.(3)

Scoring Indicators :

- a) Intensity of electric field at point is the electrostatic force experienced by unit positive charge placed at that point.
- b) 3E
- c)

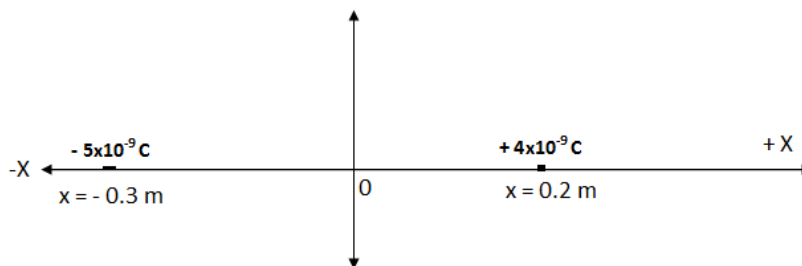

Intensity of electric field at the origin due to the negative charge

$$E_{(-)} = \frac{1}{4\pi\epsilon_0} \times \frac{5 \times 10^{-9}}{0.3^2}$$

$$E_{(-)} = 500 \text{ N C}^{-1} \text{ along } -ve \text{ x axis}$$

Intensity of electric field at the origin due to the positive charge

$$E_{(+)} = \frac{1}{4\pi\epsilon_0} \times \frac{4 \times 10^{-9}}{0.2^2}$$

$$E_{(+)} = 900 \text{ N C}^{-1} \text{ along } -ve \text{ x axis}$$

Net intensity of electric field at the origin

$$E = E_{(+)} + E_{(-)} = 500 + 900 = 1400 \text{ N C}^{-1} \text{ along } -ve \text{ x axis}$$

Q5

LO : 1.11, 1.15

Question Text

A pair of equal and opposite charges separated by a small vector distance forms an electric dipole.

- a) What is the direction of electric dipole moment? (1)
 b) What is the angle between electric dipole moment and intensity of electric field due to the dipole at its

(i) axial point outside the dipole (ii) equatorial point?

(2)

- c) An electric dipole consisting of charges $+20 \mu\text{C}$ and $-20 \mu\text{C}$ separated by 2 mm is placed inside a cubical box of side 10 cm. What is the net electric flux passing through the box?

(2)

Scoring Indicators

- a) From the negative to the positive charge along the dipole axis
 b) (i) zero (ii) 180°
 c) Total charge of the dipole $q = 0$

$$\text{Flux passing through the box } \phi = \frac{q}{\epsilon_0} \quad \phi = 0$$

Q6

LO : 1.11, 1.13

Question Text

An electric dipole placed in an electric field experiences a torque.

- a) What is the net force acting on the dipole placed in a uniform electric field? (1)
 b) Write the expression in vector form for the torque acting on an electric dipole when it is placed in a uniform electric field. (1)
 c) When a dipole is placed in a uniform electric field the torque acting on it is found to be 0.707 times the maximum torque. Calculate the angle between the intensity of electric field and electric dipole moment and draw the orientation of the dipole in the electric field. (2)

Scoring indicators

- (a) Zero
 (b) $\vec{\tau} = \vec{p} \times \vec{E}$

$$\text{Maximum torque } \tau_{max} = pE$$

$$\text{By the given condition } \tau = 0.707\tau_{max}$$

$$pE \sin \theta = 0.707 pE$$

$$\sin \theta = 0.707$$

$$\theta = \sin^{-1}(0.707) = 45^\circ$$

($\theta = 135^\circ$ is also will give the same torque)

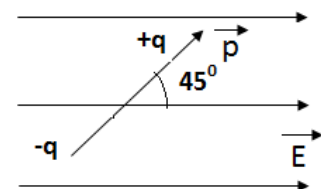

Q7

LO : 1.15

Question Text

Two closed surfaces S_1 and S_2 enclose two charges q_1 and q_2 as shown in the figure

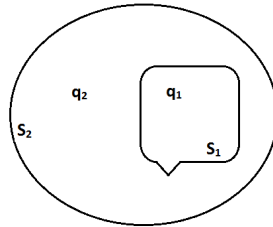

- State the law in electrostatics that relates the electric flux passing through the surface with the charge enclosed.
(1)
- If $q_1 = +6 \mu\text{C}$ and $q_2 = -4 \mu\text{C}$ find the ratio of the flux passing through surfaces S_1 and S_2
(2)
- Let the surface S_2 expands to double its area while S_1 remains as such. What will happen to the above ratio? (1)

Scoring indicators

- The net flux of electric field passing through a closed surface is equal to $1/\epsilon_0$ times the charge enclosed by the surface. (1)

- By Gauss' theorem flux passing through a surface $\phi = \frac{q}{\epsilon_0}$

$$\text{Flux passing through } S_1 \quad \phi_1 = \frac{6 \times 10^{-6}}{\epsilon_0}$$

$$\text{Flux passing through } S_2 \quad \phi_2 = \frac{(6-4) \times 10^{-6}}{\epsilon_0}$$

$$\frac{\phi_1}{\phi_2} = \frac{6}{2}$$

$$\frac{\phi_1}{\phi_2} = 3$$

- Remains the same

Chapter 10
WAVE OPTICS

Q.1.

L.O:10.1

Question text

Consider a point source emitting waves uniformly in all directions.

- (a) Draw two wave fronts very near to the point source
- (b) Using Huygen's principle ,prove that angle of incidence is equal to angle of reflection.
- (c) What is the shape of a plane wave front after passing through a thin convex lens?

Scoring indicators

(a)

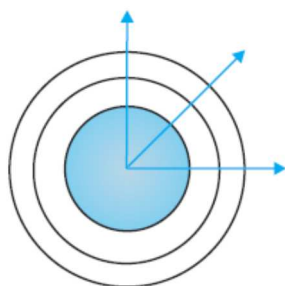

- (b) Let AB be a plane wave front incident on the reflecting surface XY. AA' and BB' be normal to the wave front at A and B. It represent incident rays. AN is the normal drawn at the point A on the reflecting surface.

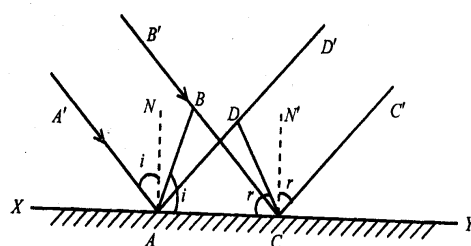

$\angle BAY$ is the angle of incidence. CD represents reflected wavefront. The normals CC' and DD' represent reflected rays. $\angle DCA$ is the angle of reflection. In the triangles ABC and ADC, $\angle ABC = \angle ADC = 90^\circ$. AC is common for both triangles. $AD = BC$. Therefore the two triangles are congruent.

$$\angle ABC = \angle ADC \quad \text{i.e } i = r.$$

- (c) Spherical wave front

Q.2.

L.O:10.2

Question text

According to a principle, at a particular point in a medium, the resultant displacement produced by a number of waves is the vector sum of the displacements produced by each of the waves.

- Name of the principle
- Derive an expression for the band width in young's double slit experiment
- What are the conditions at which two light sources become coherent?

Scoring indicators

- Superposition principle
- S_1 and S_2 are two narrow slits separated by a distance "d". They are illuminated by a monochromatic source of wavelength λ . A screen is placed at a distance of D from the slits as shown in the figure.

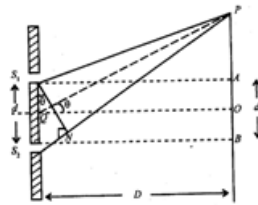

Light waves from S_1 and S_2 reach the point P. The path difference between these two waves is S_2N .

$$\text{from the } \Delta S_1S_2N \quad \sin \theta = \frac{S_2N}{S_1S_2} = \frac{S_2N}{d}$$

If θ is small, $\sin \theta = \theta \therefore$ path difference $\delta = \theta d$

$$\text{Or } \theta = \frac{\delta}{d} \dots \dots \dots (1).$$

$$\Delta PQO, \tan \theta = \frac{x}{D} \text{ or } \theta = \frac{x}{D} \dots \dots \dots (2)$$

From equation (1) and (2)

$$\frac{\delta}{d} = \frac{x}{D} \quad \text{or} \quad \delta = \frac{xd}{D}$$

For the point P to be bright, the path difference, $\delta = n\lambda$. where $n=0,1,2$ etc.

$$\text{ie } \frac{xd}{D} = n\lambda \quad \text{or } x = \frac{n\lambda D}{d}$$

The first bright fringe is formed at $x = x_1$ when $n = 1$

$$\text{ie } x_1 = \frac{\lambda D}{d}$$

Second bright fringe is formed at $x = x_2$ when $n = 2$

$$\text{ie } x_2 = \frac{2\lambda D}{d}$$

The bandwidth β the distance between two consecutive bright or dark bands.

$$\therefore \text{band width } \beta = x_2 - x_1 = \frac{\lambda D}{d}$$

- (c) Two light sources are said to be coherent if they emit light of same wavelength, same amplitude and constant or zero phase difference.

Q.3.

L.O:10.3

Question text

The double slit in Young's experiment is replaced by a single narrow slit (illuminated by a monochromatic source). Then,

- How the pattern of bands on the screen differ from the pattern due to double slit?
- Derive an expression for the band width of the central fringe.
- Draw a graph which shows the variation of intensity of light with distance .

Scoring indicators

- A broad pattern with a central bright region is seen. On both sides, there are alternate dark and bright regions of decreasing intensity
- Consider a point P, on the screen at which wavelets travelling in a direction making an angle θ with CO are brought to focus by the lens as shown in figure

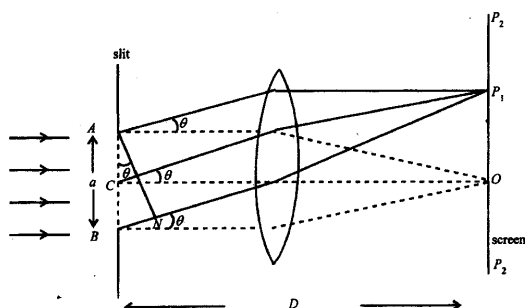

These wavelets travel unequal distances in reaching the point P_1 . Hence these waves are not in phase. The wavelets from the points A and B reaching P_1 are having a path difference, $BP_1 - AP_1 = BN = a \sin\theta$. This path difference equals to λ . Then for each point in the upper half AC of the slit, there is a corresponding point in the lower half CB such that the wavelets from these two points reach at P_1 with a path difference of $\lambda/2$.

These wavelets interfere destructively to make the intensity at P_1 minimum. The point P_1 corresponds to first minima. Condition for first minima is $a \sin\theta = \lambda$.

Thus in general, the minima will occur when the path difference = $a \sin\theta = n\lambda$ where $n = 1, 2, 3, \dots$. Thus minima are formed on both sides of O i.e., the central maxima

In between minima, other maxima called secondary maxima are formed. Secondary maxima will be at those points for which the path difference for the rays is

$$a \sin\theta = (2n + 1) \frac{\lambda}{2}$$

The width of the central maximum is defined as the distance between the first minima on either side of the central maximum.

For the first minimum, $a \sin\theta = \lambda$. when θ is small $\sin\theta = \theta$.ie $a\theta = \lambda$

Or $\theta = \frac{\lambda}{a}$. From the fig. $\theta = \frac{x}{D}$

$$\therefore \frac{x}{D} = \frac{\lambda}{a} \text{ or } x = \frac{\lambda D}{a}$$

$$\therefore \text{Width of central maximum } 2x = \frac{2\lambda D}{a}$$

(c)

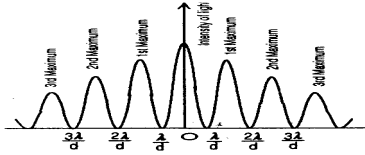
**Q.4.**

L.O:10.3,10.4

Question text

A long narrow slit is illuminated by blue light and the diffraction pattern is obtained on a white screen.

- How the width of bands change as the distance from the centre increases?
- What happens to the width of pattern, if yellow light is used instead of blue light?
- In a double slit experiment, the slits are separated by 0.03 cm and the screen is placed 1.5 m away. The distance between the central fringe and the fourth bright fringe is 1 cm. Determine the wavelength of light used in the experiment

Scoring indicators

- Width of bands decreases from the centre of the bands
- The pattern expands or band width increases

$$(c) \quad x_n = \frac{n\lambda D}{d}, \quad \therefore \lambda = \frac{x_n d}{nD} = \frac{10^{-2} \times 0.03 \times 10^{-2}}{4 \times 1.5} = 500 \text{ nm}$$

Q.5

L.O:10.5,10.6.

Question text

Light of wavelength 589 nm is used to view an object under a microscope. The aperture of the objective has a diameter of 0.900 cm.

- What do you mean by limit of resolution of an optical instrument?
- What is the limiting of resolution of the above microscope?
- What happens to the limit of resolution if the objective is immersed in oil? Explain.

Scoring indicators

- (a) The minimum distance between two objects at which they can be observed as separated by an optical instrument is called the limit of resolution of the instrument.
- (b) Limit of resolution $\Delta\theta = \frac{1.22\lambda}{D} = \frac{1.22 \times 589 \times 10^{-9}}{0.9 \times 10^{-2}} = 7.98 \times 10^{-5} \text{ rad}$
- (c) Decreases. Refractive index of oil is more than that of air. Hence wavelength of the light decreases.

Q.6

L.O:10.2.

Question text

A slit S is illuminated by a monochromatic source of light to give two coherent sources P_1 and P_2 . These give a dark band at the point R on the screen as shown in figure.

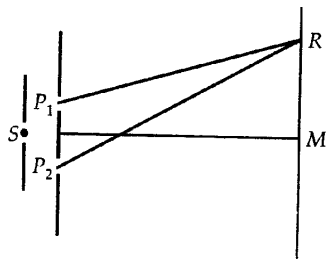

- (a) Write the formula to find out band width.
- (b) What relationship must exist between the lengths P_1R and P_2R ?
- (c) Can interference fringes be produced by using two identical bulbs?
- (d) If the distance between P_1 and P_2 is 1mm and the screen is placed 1m away, what is the fringe separation for a light of wavelength $5 \times 10^{-7} \text{ m}$?

Scoring indicators

- (a) $\beta = \frac{\lambda D}{d}$
- (b) The condition for dark fringe is $P_2R - P_1R = (2n - 1) \frac{\lambda}{2}$ / Where $n = 1, 2, 3$ etc
- (c) no
- (d) $\beta = \frac{\lambda D}{d} = \frac{1 \times 5 \times 10^{-7}}{10^{-3}} = 5 \times 10^{-4} = 0.5 \text{ mm}$

Q.7

L.O:10.7,8.

Question text

Green light is incident at the Polarizing angle on a certain glass plate as shown in figure.

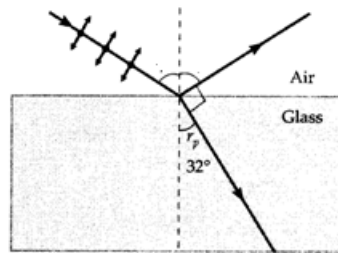

- What do you mean by polarizing angle?
- Indicate the polarization components on the reflected and refracted rays, by arrows and dots.
- Find the refractive index of glass.

Scoring indicators

- The angle of incidence, at which incident light on a transparent medium, become completely plane polarized is known as polarizing angle.
-

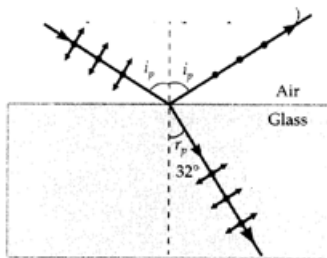

- Polarizing angle = $90^\circ - 32^\circ = 58^\circ$
Refractive index, $n = \tan 58^\circ = 1.6$

Q.8

L.O:10.7,10.8.

Question text

A beam of light, with intensity I_0 , is passing through a polarizer and an analyzer as shown in figure.

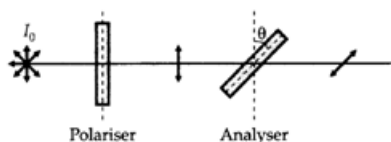

- State Malus law related to the intensity of light transmitted through the analyzer.
- If $\theta = 45^\circ$, What is the relation of the intensities of original light and transmitted light after passing through the analyzer?
- Which of the following waves can be polarized (i) X-rays (ii) sound waves Why?

Scoring indicators

(a) The Malus law states that the intensity of the polarized light transmitted varies as the square of the cosine of the angle between the plane of transmission of the analyser and plane of polarizer.

$$(b) \frac{I_{\text{original}}}{I_{\text{transmitted}}} = \frac{I_0}{\frac{I_0}{2} \cos^2 45^\circ}$$

$$\frac{I_{\text{original}}}{I_{\text{transmitted}}} = \frac{1}{\frac{1}{2} \times \frac{1}{2}} = 4 : 1$$

(c) X-rays . Because it is a transverse wave.

DUAL NATURE OF MATTER AND RADIATION

Q1.

LO : 11.2,11.3

Question Text

Einstein got Nobel prize in 1921 for his explanation of photoelectric effect

- a) In order to start photoelectric emission, the minimum energy acquired by free electron in the metal is called as
(1)
- b) The minimum energy for the emission of an electron from metallic surface is given below
Na : 2.75 eV K : 2.3 eV Mo : 4.17 eV Ni : 5.15 eV
Select the metal which is more photo sensitive? Why (1)
- c) Draw variation of photoelectric current with applied voltage for radiation of intensities I_1 and I_2 ($I_1 > I_2$). Comment on the relation between intensity of light and photoelectric current. (2)
- d) Does Light from a bulb falling on an iron table emit photoelectron ? Justify your answer. (2)

Scoring Indicator

- a) Work function / Threshold energy
- b) K is more photosensitive because it has less work function
- c)

FIGURE

As intensity increases photoelectric current also increases

- d) No. The work function of iron is very large
-

Q2.

L.O : 11.2

Question Text

Figure below shows variation of stopping potential (V_0) with frequency (γ) of incident radiations for two different metals A and B .

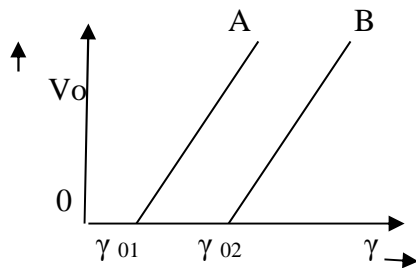

- Write down the values of work function A and B? (1)
- What is the significance of slope of the above graph? (1)
- The value of stopping potential for A and B for a frequency γ_1 (which is greater than γ_{02}) of incident radiations are V_1 and V_2 respectively. Show that the slopes of the lines is equal to $\frac{V_1 - V_2}{\gamma_{01} - \gamma_{02}}$ (3)

Scoring Indicators

- Work function of A, $\phi_{01} = h \nu_{01}$
Work function of B, $\phi_{02} = h \nu_{02}$
- The slope of the graph gives value of h/e .
For the metal A, $h \nu_1 = h \nu_{01} + eV_1$ (1) \longrightarrow
For the metal B, $h \nu_1 = h \nu_{02} + eV_2$ (2) \longrightarrow
From equation (1) and (2)
 $h \nu_{01} + eV_1 = h \nu_{02} + eV_2$
 $e(V_1 - V_2) = h(\nu_{02} - \nu_{01})$
 $\frac{h}{e} = \frac{V_1 - V_2}{\nu_{02} - \nu_{01}}$

Q 3.

LO : 11.5, 11.6

Question Text

Photon is quanta of light

- How introduced the concept of photon? (1)
- List any four properties of photon? (2)
- What will be the de-broglie wave length of moving particle with velocity v and that of a photon? (1)

Scoring Indicators

- Max Plank
- In interaction of radiation with matter, it behaves as if it is made up of particles called photons
 - Photon has energy ($E = h \nu$) and momentum $p = h \nu / c$ and speed c as that of light
 - Photons are electrically neutral

- iv) When photon collide with a particle the collision is elastic
- c) de-Broglie wavelength of particle $\lambda = \frac{p}{mv}$
 de-Broglie wavelength of photon $\lambda = \frac{p}{mc}$

Q4.

LO : 11.3

Question Text

Lenard and Hallwachs investigated the phenomenon of photoelectric effect in details during 1886-1902 through experiments

- a) Write any two characteristic features observed in the above experiment? (2)
- b) Explain with reason
 (i) Green light emit electron from certain metal surface while yellow light does not
 (ii) When the wavelength of incident light is decreased, the velocity of emitted photo electrons increases (2)
- c) Complete the following statement about photoelectric effect
 The radiations having minimum frequency called falls on a metallic surface, electrons are emitted from it. The metal which emits photoelectrons are called
 The kinetic energy of photoelectrons emitted by a metal depends on of the radiations, while the intensity of the incident radiations depends on
 (2)

Scoring Indicators

- a) Any two statement of laws of photoelectric effect (2)
- b) (i) Energy of incident photon is inversely proportional to its wavelength. Since λ of green light is less than that of yellow, it has larger energy. So it can emit photoelectrons (1)
 (ii) As the wavelength decreases, frequency and hence energy of incident radiation increases and hence kinetic energy of photo electrons increases (1)
- c) Threshold frequency , photosensitive ,frequency, number of photons (2)

Q5.

LO : 11.4

Question Text

Albert Einstein proposed a radically new picture of electromagnetic radiation to explain photoelectric effect

- a) Identify Einstein's photoelectric equation ? (1)
- b) With the help of Einstein's photoelectric equation explain the following facts
- Kinetic energy of photoelectrons is directly proportional to frequency not on intensity
 - Existence of threshold frequency for a given photosensitive material (2)
- c) A metal whose work function is 2 eV is illuminated by light of wavelength $3 \times 10^{-7} \text{m}$. Calculate i) threshold frequency ii) maximum energy of photoelectrons. iii) the stopping potential ? (3)

Scoring Indicators

- a) $h\nu = h\nu_0 + \frac{1}{2}mv^2$
- b) i) $h\nu \propto \frac{1}{2}mv^2$
 $\frac{1}{2}mv^2 \propto \nu$
 Hence kinetic energy is proportional to frequency
- ii) $h\nu - h\nu_0 = \frac{1}{2}mv^2$
 $h(\nu - \nu_0) = \frac{1}{2}mv^2$
 ν should be greater than ν_0 , otherwise $h(\nu - \nu_0)$ is negative and is not possible
- c) $\phi_0 = h\nu_0 = 2\text{eV}$
 $\nu = \frac{c}{\lambda}$
 $= \frac{3 \times 10^8}{3 \times 10^{-7}} = 10^{15} \text{ Hz}$
- (i) $\phi_0 = h\nu_0$
 $\nu_0 = \frac{2 \times 1.6 \times 10^{-19}}{6.63 \times 10^{-34}}$
 $= 4.8 \times 10^{14} \text{ Hz}$
- (ii) $\frac{1}{2}mv^2 = h(\nu - \nu_0)$
 $= 6.63 \times 10^{-34} (10^{15} - 4.8 \times 10^{14})$
 $= 3.44 \times 10^{-19} \text{ J}$
- (iii) $eV_0 = h(\nu - \nu_0)$
 $V_0 = \frac{h(\nu - \nu_0)}{e}$
 $= \frac{3.44 \times 10^{-19}}{1.6 \times 10^{-19}}$
 $= 5.746 \text{ V}$

Q.6.

LO : 11.7

Question Text

The wave nature of electron was experimentally verified by diffraction of electron by Nickel crystal

- (a) Name the experiment which establish wave nature of moving electron? (1)
- (b) With a neat diagram explain the existence of matter wave associated with an electron?(3)
- (c) An electron and a proton have same kinetic energy which of these particles has shortest de – Broglie wave length ? (2)

Scoring Indicator

- a. Davisson and Germer experiment
- b.

FIGURE

Explanation

$$\begin{aligned} \text{c. } \lambda &= \frac{h}{p} \\ K &= \frac{p^2}{2m} \\ P &= \sqrt{2mK} \\ \lambda &= \frac{h}{\sqrt{2mK}} \\ \lambda &\propto \frac{1}{\sqrt{m}} \end{aligned}$$

Mass of alpha particle is more than that of proton, hence it has shortest wavelength

Chapter 12
ATOMS

Q1.

LO: 12.1, 12.2

Question Text

In Geiger-Marsden Scattering experiment alpha particles of 5.5 MeV is allowed to fall on a thin gold foil of thickness $2.1 \times 10^{-7} \text{m}$

- (a) Draw Schematic diagram of above experimental arrangement. (2)
(b)

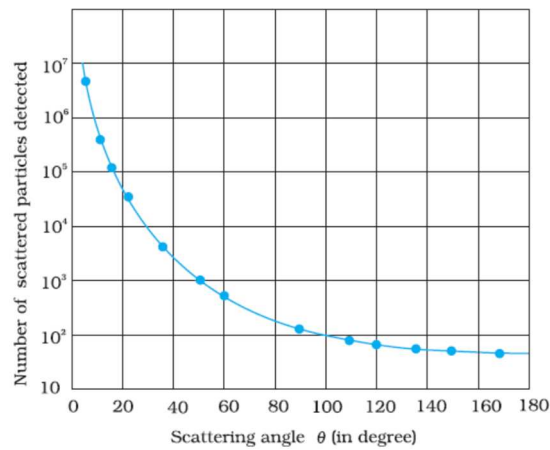

In the above graph nearly 10^7 particles were detected when scattering angle is Zero. What you understand by it? (1)

- (c) Why gold foil is used in this experiment? (2)
(d) Does there exist any relation between impact parameter and scattering angle? If yes explain your answer? (1)

Scoring Indicator

a)

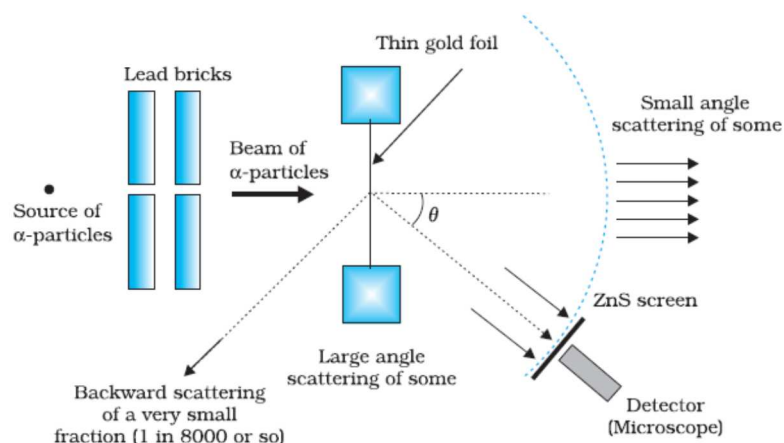

- (b) Most of the alpha particles get unscattered means that most of the space in an atom is empty. (1)
- (c) Atomic number of gold is 79, so number of protons is very high. Hence scattering between alpha and nucleons is larger. Gold foil can be made very thin so that the alpha particles suffer not more than one scattering. (2)
- (d) Yes
As impact Parameter increases, scattering angle decreases. (3)

Q2.

LO: 12.5, 12.6, 12.9

Question Text

Study of emission line spectra of a material serve as a fingerprint for identification of the gas.

- (a) Name different series of lines observed in hydrogen spectrum (1)
- (b) Draw energy level diagram of hydrogen atom? (2)
- (c) Write down the Balmer formula for wave length of H_{α} line. (1)
- (d) Given Rydberg constant as $1.097 \times 10^7 \text{ m}^{-1}$. Find the longest and shortest wavelength limit of Balmer Series. (2)

Scoring Indicator

- a) Lyman series, Balmer series, Paschen series, Bracket series, Pfund Series.

b)

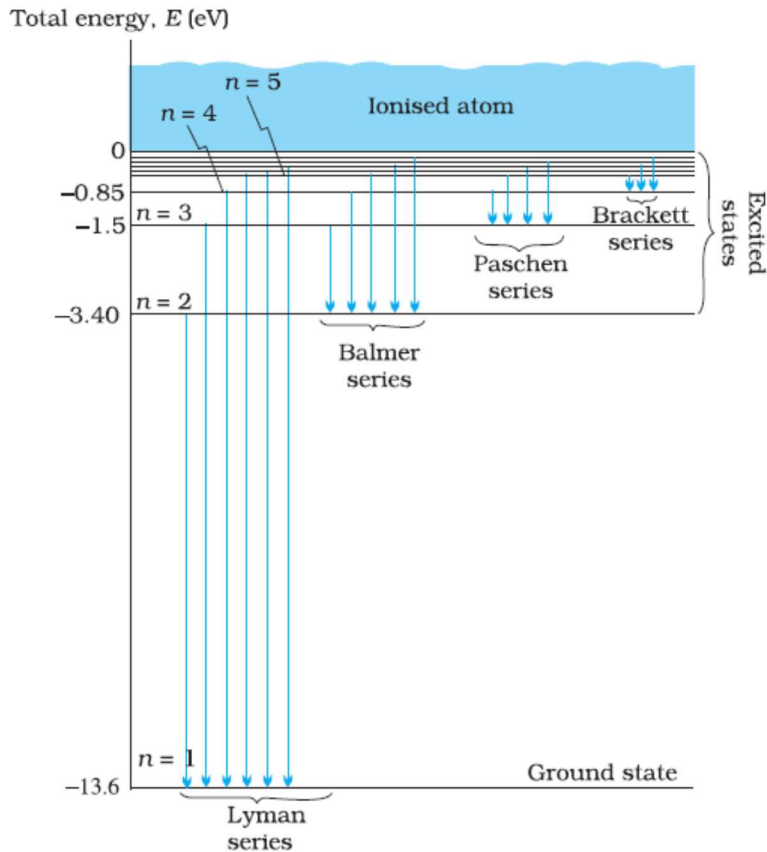

$$c) \quad \bar{\nu} = \frac{1}{\lambda} = R_H \left[\frac{1}{n_1^2} - \frac{1}{n_2^2} \right] = R_H \left[\frac{1}{2^2} - \frac{1}{3^2} \right]$$

$$d) \quad \bar{\nu} = \frac{1}{\lambda} = R_H \left[\frac{1}{n_1^2} - \frac{1}{n_2^2} \right]$$

Longest wavelength $n_1 = 2$ and $n_2 = 3$

$$\bar{\nu} = \frac{1}{\lambda} = R_H \left[\frac{1}{n_1^2} - \frac{1}{n_2^2} \right] = R_H \left[\frac{1}{2^2} - \frac{1}{3^2} \right] = 1.097 \times 10^7 \times \frac{5}{36}$$

$$\lambda = \frac{1}{R_H \left[\frac{1}{2^2} - \frac{1}{3^2} \right]} = 6563 \times 10^{-10} \text{ m}$$

Shortest Wavelength $n_1 = 2$ and $n_2 = \infty$

$$\bar{\nu} = \frac{1}{\lambda} = R_H \left[\frac{1}{n_1^2} - \frac{1}{n_2^2} \right] = R_H \left[\frac{1}{2^2} - \frac{1}{\infty^2} \right]$$

$$\lambda = \frac{1}{R_H \left[\frac{1}{2^2} - \frac{1}{\infty^2} \right]} = \frac{1}{1.097 \times 10^7 \left(\frac{1}{4} \right)} = 3646 \times 10^{-10} \text{ m}$$

Q3.

LO: 12.7

Question Text

Bohr combined classical and early quantum concept and gave his theory in the form of three postulates.

- (a) State three postulates of Bohr Model of atom? (2)
 (b) The total energy of an electron in ground state of hydrogen atom is - 13.6 eV. What is the significance of negative sign? (1)
 (c) The radius of inner most electron orbit of hydrogen atom is 5.3×10^{-11} m. What are the radii of $n=2$ and $n=3$ orbits? (2)

Scoring Indicators

- (a) State 3 Postulates
 (b) Negative sign implies that the electrons are strongly bounded to the nucleus
 (c) $r_n = n^2 a_0 = 5.3 \times 10^{-11} \text{m}$
 $r_1 = a_0 = 5.3 \times 10^{-11} \text{m}$
 $r_2 = 4a_0 = 21.2 \times 10^{-11} \text{m}$
 $r_3 = 9a_0 = 47.7 \times 10^{-11} \text{m}$

Q.4

LO : 12.11

Question Text

Louis de Broglie argued that electron in circular orbit as proposed by Bohr, must be seen as a Particle wave.

- a) From Bohr's postulate of angular quantization momentum, arrive at an expression for wave length of an orbital electron? (2)
 b) Comment on the above result. (2)

Scoring Indicators

- (a) $mvr = nh$ (1)

$$\lambda = \frac{h}{mv} \text{ (2)}$$

From (1) & (2)

$$\frac{hr}{\lambda} = \frac{nh}{2\pi}$$

$$\lambda = \frac{2\pi r}{n}$$

- c) Since $\lambda = \frac{2\pi r}{n}$, length of the first orbit is the de- Broglie wave length of the orbit.

Chapter 13
NUCLEI

Q 1

L.O:13.1,13.2

Question Text

(a) Complete the given nuclear reaction.



(b) Match the following.

	A	B
i	Isotopes	${}_{17}\text{Cl}^{37}, {}_{19}\text{K}^{39}$
ii	Isobars	${}_8\text{O}^{16}, {}_8\text{O}^{17}$
iii	Isotones	${}_1\text{H}^3, {}_2\text{He}^3$
iv		${}^1_3\text{H}, {}^3_7\text{Li}$

Scoring Indicators:

a) ${}_Z X^A + {}_{-1}e^0 \rightarrow {}_{Z-1}X^A + \nu + \text{Energy}$

b)

	A	B
i	Isotopes	${}_8\text{O}^{16}, {}_8\text{O}^{17}$
ii	Isobars	${}_1\text{H}^3, {}_2\text{He}^3$
iii	Isotones	${}_{17}\text{Cl}^{37}, {}_{19}\text{K}^{39}$

Q 2

L.O: 13.3

Qn Text:

Nuclear radius depends on the mass number of the element.

- Write down the expression for nuclear radius.
- Prove that the density of the nucleus is independent of mass number A.
- Read the following statement and choose the correct option.

“Electric dipole moment is zero for nuclei in stationary state.”

Assertion

All nuclei have spherical symmetry about the centre of mass.

Reason:

The zero dipole moment for stationary nuclei is due to the symmetry about the centre of mass.

i) Assertion and reason are true. ii) Assertion is false reason is true. iii) Assertion is true reason is false iv) Assertion and reason are false.

Scoring indicators:

a) $R = R_0 A^{\frac{1}{3}}$

b) Density of nucleus = (mass of the nucleus) / (volume of the nucleus)

$$= \frac{mA}{\left(\frac{4}{3}\right)\pi R^3} = \frac{mA}{\frac{4}{3}\pi R_0^3 A} = \frac{m}{\frac{4}{3}\pi R_0^3}$$

This shows that nuclear density is independent of mass number

c) ii) Assertion is false reason is true.

Q 3

L.O: 13.4,13.5

Qn Text

Binding energy curve shows the variation of Binding energy per nucleon of nuclei with mass number.

- a) Binding energy per nucleon is maximum for mass number.....
 b) The figure shows disintegration of Deuteron.

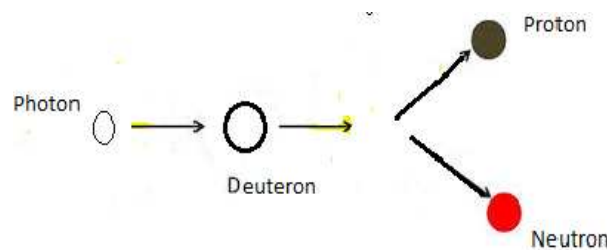

What should be the frequency of the incident photon to break Deuteron into proton and neutron?

Mass of proton $m_p = 1.007276$ u.

Mass of neutron $m_n = 1.008665$ u

Mass of deuteron = 2.013553u

Scoring Indicators:

a) 56

b) Mass defect = $(1.007276 + 1.008665) - 2.013553 = 0.002388$ u

Binding Energy = $0.002388 \times 931 \text{ MeV} = 2.223 \text{ MeV}$

Energy supplied to the photon = $2.223 \times 10^6 \times 1.6 \times 10^{-19} = 3.56 \times 10^{-13} \text{ J}$

Frequency of photon $\nu = \frac{E}{h} = \frac{3.56 \times 10^{-13}}{6.62 \times 10^{-34}} = 5.4 \times 10^{20} \text{ Hz}$

Q 4

L.O:13.6

Q. Text

The figure shows the potential energy of a pair of nuclear particles and their distance of separation in Fermi (fm).

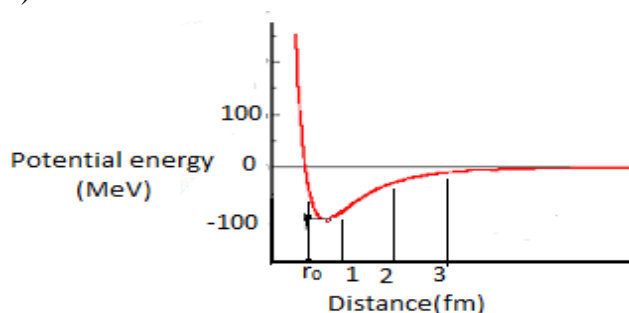

a) Fill in the blanks.

Distance of separation	Potential energy	Nuclear force
$r > 3 \text{ fm}$		
$r_0 < r < 3 \text{ fm}$		Nuclear force is attractive
$r < r_0$	Potential energy positive	

b) What conclusion do you obtain about the nature of nuclear force from the graph.

Scoring indicators

a)

Distance of separation	Potential energy	Nuclear force
$r > 3 \text{ fm}$	Potential energy very small and negative	No nuclear force
$r_0 < r < 3 \text{ fm}$	Potential energy is negative	Nuclear force is attractive
$r < r_0$	Potential energy positive	Nuclear force is repulsive

b) The nuclear force is a short range force.

Q 5

L.O: 13.7,13.8,13.9

Rutherford and Soddy's laws of radioactivity explain the rate of decay of radioactive material.

a) Arrive at the expression for the number of radioactive atoms of a radioactive material remaining after an interval of time.

- b) Draw the curve showing the variation of $\log\left(\frac{N}{N_0}\right)$ with time.
- c) Two radioactive substances P and Q have half-life 6 months and 3 months respectively. Find the ratio of the activity of these two materials after one year. **Score: 3+1+2**

Scoring Indicators:

- a) If N is the number of nuclei in the sample and ΔN undergo decay in time Δt then

$$\frac{\Delta N}{\Delta t} \propto N$$

$$\text{or, } \Delta N/\Delta t = \lambda N,$$

where λ is called the radioactive *decay constant* or *disintegration constant*.

The change in the number of nuclei in the sample* is $dN = -\Delta N$ in time Δt . Thus the rate of change of N is (in the limit $\Delta t \rightarrow 0$)

$$\frac{dN}{dt} = -\lambda N$$

or,

$$\frac{dN}{N} = -\lambda dt$$

Now, integrating both sides of the above equation, we get,

$$\int_{N_0}^N \frac{dN}{N} = -\lambda \int_{t_0}^t dt$$

$$\text{or, } \ln N - \ln N_0 = -\lambda (t - t_0)$$

Here N_0 is the number of radioactive nuclei in the sample at some arbitrary time t_0 and N is the number of radioactive nuclei at any subsequent time t . Setting $t_0 = 0$ and rearranging Eq. gives us

$$\ln \frac{N}{N_0} = -\lambda t \quad \text{which gives } N(t) = N_0 e^{-\lambda t}$$

b)

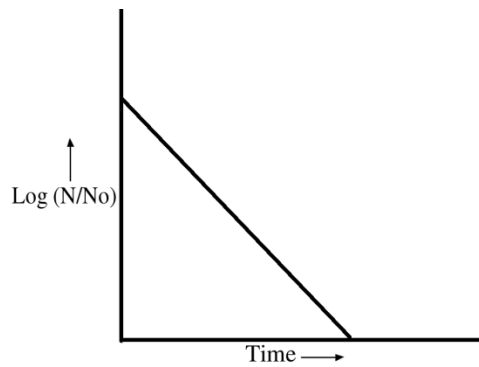

a) Activity $R = \lambda N$

$$R_1 = \lambda_1 N_1$$

$$R_2 = \lambda_2 N_2$$

$$\lambda_1 = \frac{0.693}{T_{1/2}} = \frac{0.693}{6}$$

$$\lambda_2 = \frac{0.693}{T_{1/2}} = \frac{0.693}{3}$$

$$N_1 = \frac{N_0}{2}$$

$$N_2 = \frac{N_0}{4}$$

$$\frac{R_1}{R_2} = \frac{\lambda_1 N_1}{\lambda_2 N_2}$$

$$= \frac{\left(\frac{0.693}{6}\right) \left(\frac{N_0}{2}\right)}{\left(\frac{0.693}{3}\right) \left(\frac{N_0}{4}\right)} = 1$$

$$R_1 : R_2 = 1 : 1$$

Q 6

L.O:13.10

a) In the given figure a radioactive source is placed inside a lead block.

Identify the rays incident on the photographic plates

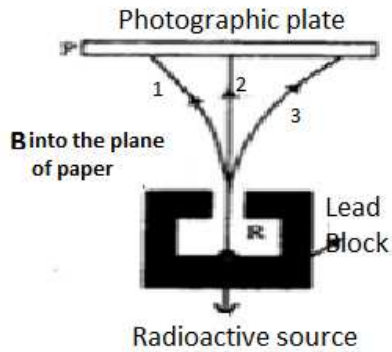

- b) Which of the following statement is correct .
- Gamma rays consist of high energy neutrons.
 - Alpha rays are equivalent to singly ionized He atoms.
 - Protons and neutrons have exactly the same mass.
 - Beta rays are same as cathode rays.
- c) How many alpha and beta particles are emitted in the following reaction.
- $${}_{92}\text{U}^{238} \rightarrow {}_{82}\text{Pb}^{206}$$

Scoring Indicators

a)

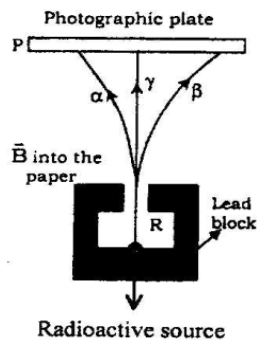

- 1-Alpha
- 2-Gamma
- 3-Beta

b) iv) Beta rays are same as cathode rays.

c) ${}_{92}\text{U}^{238} \rightarrow {}_{82}\text{Pb}^{206}$

Difference in mass number=32

Mass number of one alpha particle =4

Hence number of alpha particles = 8

Change in atomic number = 10

Change in atomic number due to alpha particles = 16

Charge of beta particles = -1

Hence number of beta particles emitted = 6

Q 7

L.O: 13.11 ,13.12,13.7

a) Match the following:

	A	B
i	Nuclear fission	β -decay
ii	Nuclear fusion	Hydrogen spectrum
Iii	Transition between atomic energy levels	Nuclei with low atomic numbers
iv	Electron emission from nucleus	Generally possible for nuclei with high atomic number
		Photo electric emission

b) Nuclear fusion can liberate more energy than nuclear fission. But nuclear fusion is not commonly used in energy production. Why? Score:2+1

Scoring Indicators:

	A	B
i	Nuclear fission	Generally possible for nuclei with high atomic number
ii	Nuclear fusion	Nuclei with low atomic numbers
Iii	Transition between atomic energy levels	Hydrogen spectrum
iv	Electron emission from nucleus	β - decay

Q 8

L.O:13.12

The figure shows a nuclear reactor based on thermal neutron fission.

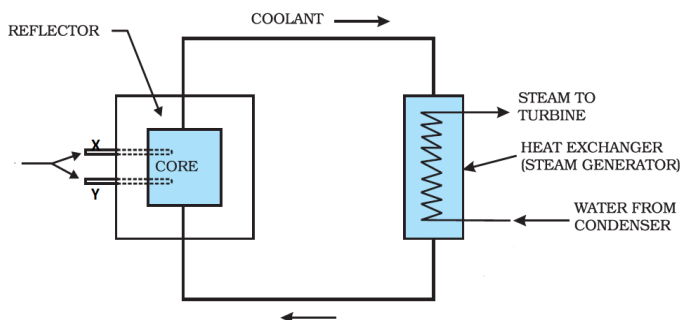

- The energy of thermal neutrons is -----ev.
- Name the parts labelled X and Y in the figure.
- Write the function of X and Y.
- The multiplication factor has great significance in nuclear reactor .Give reason.

Score: 1+1+1+2

Scoring Indicators:

- 0.025eV

- b) Control rods
- c) **Control rods are used in** nuclear reactors to control the fission rate of Uranium and Plutonium.
- d) The ratio, K , of number of fission produced by a given generation of neutrons to the number of fission of the preceding generation is called the *multiplication factor*; it is the measure of the growth rate of the neutrons in the reactor. For $K = 1$, the operation of the reactor is said to be *critical*, Unless the factor K is brought down very close to unity, the reactor will become supercritical and can even explode.

SEMICONDUCTOR ELECTRONICS: MATERIALS, DEVICES AND SIMPLE CIRCUITS

Q.1.

L.O:14.3,14.4,14.5

Question text

Diodes are one of the building elements of electronic circuits. Some type of diodes are shown in the figure.

(i)



(ii)



(iii)



- (a) Identify rectifier diode from the figure.
- (b) Draw the circuit diagram of a forward biased rectifier diode by using a battery
- (c) Draw the forward and reverse bias characteristics of a rectifier diode and mark threshold voltage or cut in voltage .
- (d) What happens to the resistance of a semiconductor on heating?

Scoring indicators:

(a)



(b)

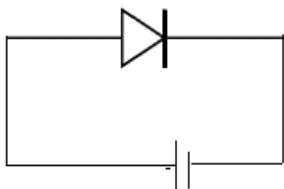

- (c) The forward and reverse characteristics of a silicon diode is as shown in the fig.

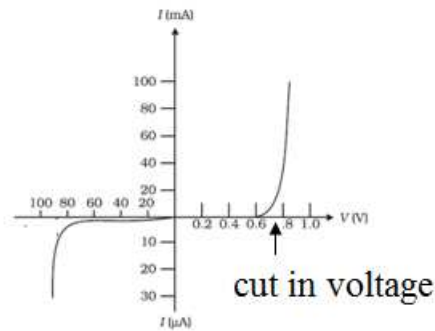

- (d) The resistance of a semiconductor decreases with rise in temperature

Q.2

L.O:14.6,14.7,14.8

Question text

A full wave rectifier circuit is shown in figure .

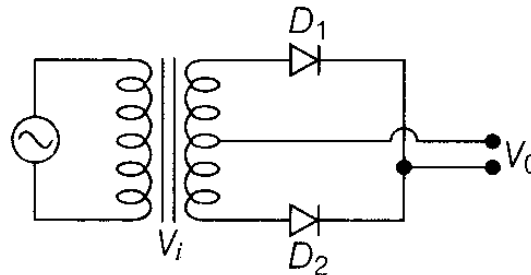

- (a) Draw the output wave form of the rectifier
 (b) If a full wave rectifier circuit is operating from 50 Hz mains, the fundamental frequency in the ripple will be
 (a) 50 Hz (b) 70.7 Hz (c) 100 Hz (d) 25 Hz
 (c) In a zener regulated power supply, a zener diode with $V_z = 6.0$ V is used for regulation. The load current is to be 4.0 mA and the unregulated input 10.0 V. What is the value of series resistor R?

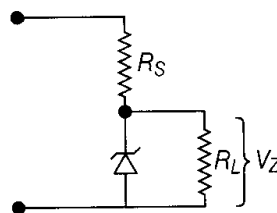

Scoring indicators:

- (a)

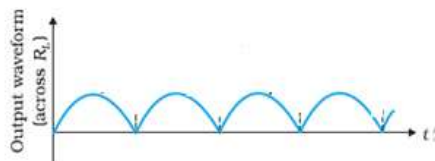

- (b) 100Hz

- (c) The voltage drop on the resistor should be 4V

$$\therefore R = \frac{V}{I} = \frac{4}{4 \times 10^{-3}} = 1\text{k}\Omega$$

Q.3

L.O:14.1,14.2,

Question text

The following diagram shows energy bands in a semiconductor

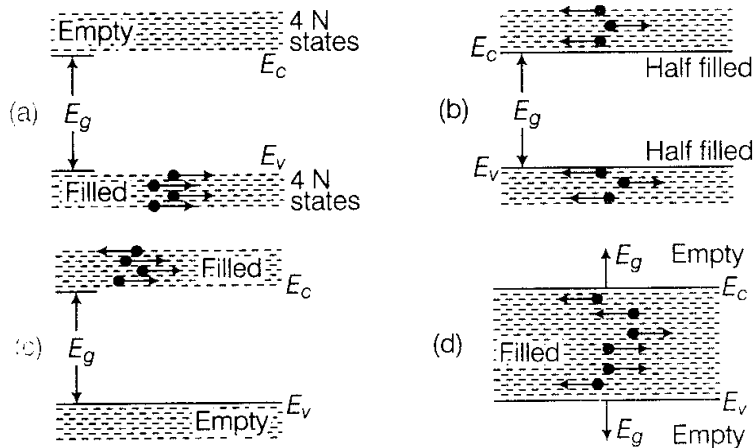

- (a) which diagram shows energy band positions at 0K
 (b) What do you mean by energy gap? Match the elements /compounds with their respective energy gap values.

Column I	Column II
A. Diamond	1. 1.1 eV
B. Aluminium	2. 0.71 eV
C. Germanium	3. 0.03 eV
D. Silicon	4. 6 eV

- (c) Classify solids into conductors, semiconductors, and insulators by drawing energy diagram

Scoring indicators:

- (a)

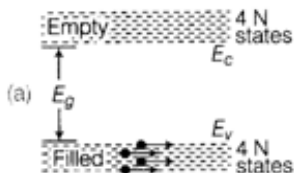

- (b) The gap between the top of the valence band and bottom of the conduction band is called the *energy band gap*

Diamond	6 eV
Aluminium	0.03 eV
Germanium	1.1 eV
Silicon	0.71 eV

(c) for conductors

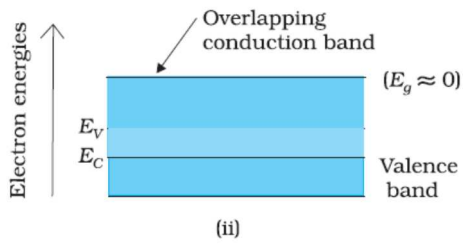
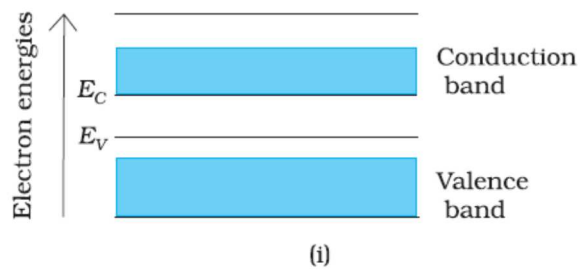

For semiconductors

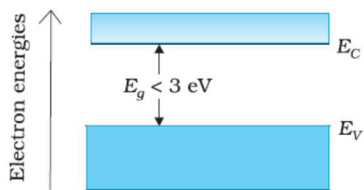

For insulators

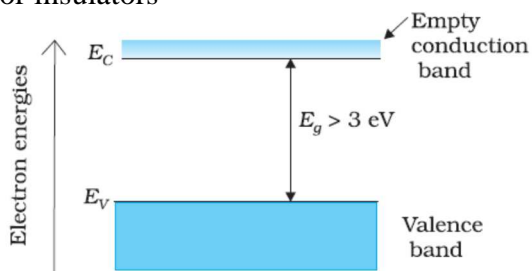

Q.4

L.O:14.1,14.2,14.3

Question text

Forward biased pn junction diodes are shown in the figure

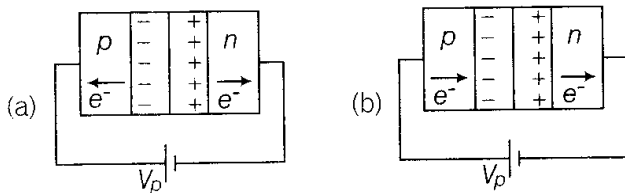

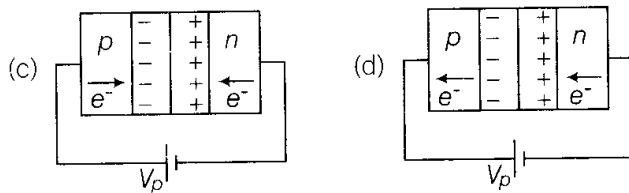

- (a) Identify the figure, which shows the correct direction of flow of charges
- (b) What do you mean by barrier potential and depletion region of a pn junction?
- (c) When forward bias is applied to a p-n junction, what happens to the potential barrier and the width of depletion region.

Scoring indicators:

(a)

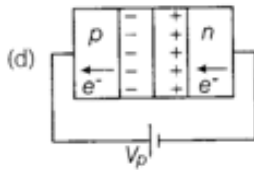

- (b) The potential developed across the junction, which tends to prevent the movement of electron from the n region into the p region, in semiconductor is called a barrier potential.

The space-charge region on either side of the junction at which there is no free charge carriers is known as depletion region.

- (c) The potential barrier decreases and depletion region reduced.

Q.5

L.O:14.6,14.7

Question text

LEDs that can emit red, yellow, orange, etc commercially available.

- (a) How these colours are obtained in a LED
- (b) Write any two uses of LED
- (c) What are its advantages over ordinary bulbs ?

Scoring indicators:

- (a) Different colours are obtained by changing the concentration of arsenic and phosphorus in Gallium Arsenide Phosphide.
- (b) LEDs find extensive use in remote controls, burglar alarm systems, optical communication, etc.
- (c) LEDs have the following advantages over conventional incandescent low power lamps:
- (i) Low operational voltage and less power.
 - (ii) Fast action and no warm-up time required.
 - (iii) The bandwidth of emitted light is 100 \AA to 500 \AA or in other words it is nearly (but not exactly) monochromatic.
 - (iv) Long life and ruggedness.
 - (v) Fast on-off switching capability.

Q.6

L.O:14.9,14.10,14.11

Question text

The symbol of a n-p-n transistor is shown in figure.

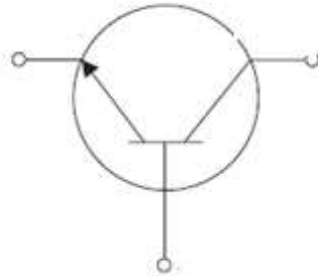

- Redraw the symbol and mark emitter, collector, and base of the transistor
- Arrange the doping concentration and width of emitter, collector and base regions in ascending order
- What happens when both the emitter and the collector of a transistor are forward biased?

Scoring indicators:

(a)

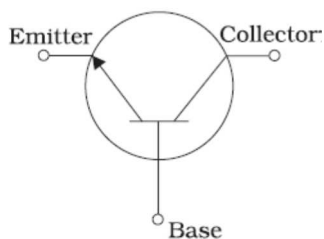

- doping concentration of base < doping concentration of collector < doping concentration of emitter. Width of base < Width of emitter < Width of collector
- The transistor will work as two *p-n* junctions with common base terminals.

Q.7

L.O:14.10,14.11,14.12

Question text

The given figure shows a npn transistor.

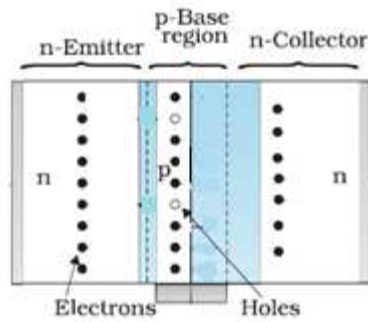

- Redraw the figure and show the biasing voltage, direction of current and direction of flow of electrons and holes.
- Draw the input and output characteristics of transistor connected in common emitter configuration
- In a transistor, a change of 7.9 mA is observed in the collector current for a change of 7.99 mA in the emitter current. Determine the change in base current.

Scoring indicators:

(a)

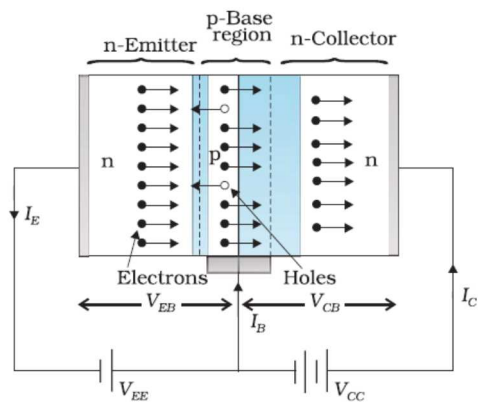

(b) input characteristic

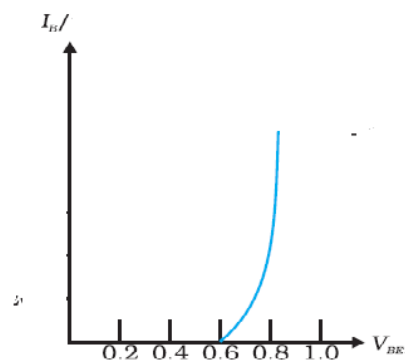

Out put characteristics

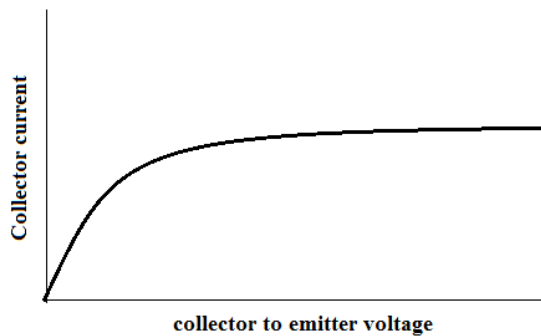

(c)

$$\begin{aligned}\Delta I_E &= \Delta I_C + \Delta I_B \\ \Delta I_B &= \Delta I_E + \Delta I_C \\ &= 7.99 - 7.9 = 0.09 \text{ mA}\end{aligned}$$

Q.8

L.O:14.10,14.11,14.12

Question text

The transfer characteristic of n-p-n transistor in CE configuration is shown in the figure

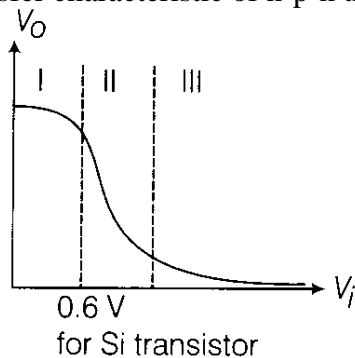

- Identify the cut-off region, active region, saturation region from the figure
- In which of these regions, a transistor is said to be switched off
- For a CE transistor amplifier, the audio signal voltage across collector resistance of $2.0 \text{ k}\Omega$ is 2.0 V . Suppose the current amplification factor of the transistor is 100. What should be the value of R_B in series with V_{BB} supply of 2.0 V , if DC base current has to be 10 times the signal current?
- In the working of a transistor, the emitter-base (EB) junction is forward biased while collector-base (CB) junction is reverse biased. Why ?

Scoring indicators:

- I-cut off region
II- active region
III-saturation region
- Region I
-

$$I_c = \frac{2}{2000} = 1 \text{ mA}, \quad \beta = \frac{I_c}{I_b}, \quad \therefore I_b = \frac{I_c}{\beta} = \frac{1 \text{ mA}}{100} = 10^{-5} \text{ A}$$

$$I_{dc} = 10^{-5} \times 10 = 10^{-4} \text{ A},$$

$$V_{bb} = V_{be} + I_b R_b, \therefore R_b = \frac{V_{bb} - V_{be}}{I_b} = \frac{2 - 0.6}{10^{-4}} = 14 \text{ k}\Omega$$





- (d) Only forward biased emitter-base junction can send the majority charge carriers from emitter to base and only reverse biased collector can collect these majority charge carriers from the base region.

Q.9

L.O:14.16

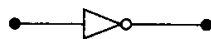
Question text

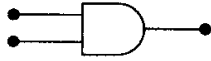
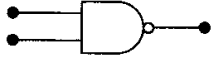
The basic building blocks of digital electronic circuits are called *Logic Gates*. Some logic gates and their names are given in the table

	Column I	Column II
A.		1. OR
B.		2. AND
C.		3. NAND
D.		4. NOR
E.		5. NOT

- (a) Match the symbols of logic gates with their names.
- (b) Draw the output wave form, from the given input waveform of a NAND gate as shown in figure (input terminals are A and B).

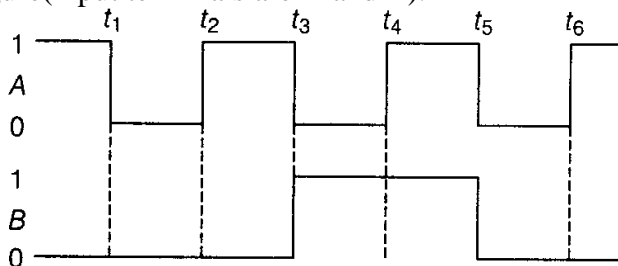

- (c) Write the truth table for the given circuit



Scoring indicators

- (a) A-5, B-1, C-2, D-3, E-4
 (b)

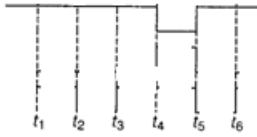

(c)

A	B	\bar{A}	$Y = \bar{A} + B$
0	0	1	1
0	1	1	1
1	0	0	0
1	1	0	1

COMMUNICATION SYSTEMS

Q.1

L.O:15.1

Question text

The given block diagram shows general form of a communication system

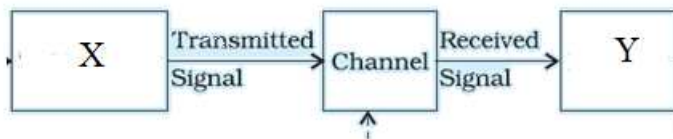

- Identify the parts X and Y in the diagram
- What is the difference between (i) transmitter and receiver and (ii) Attenuation and Amplification
- Repeaters are used ;
 - to decrease the range of a communication system
 - to increase the range of a communication system
 - both (i) and (ii)

Scoring indicators

- X-transmitter, Y-receiver
- A transmitter converts message signal into a form suitable for transmission. A receiver receives the transmitted signal and reconstructs the message signal.
 - The loss of strength of signal while passing through the medium is known as attenuation .The process of increasing the amplitude of a signal is known as amplification.
- Repeaters are used to increase the range of a communication system.

Q.2

L.O:15.2

Question text

The type of communication system needed for a given signal depends on the band of frequencies in the signal

- What are the different types of message signals used in a communication systems.
- Match the band width given in column B with the signal given in column A

Column A	Column B
speech signals,	6 MHz
Music signals	2.8 kHz
Video signals	20 kHz
TV signal	4.2 MHz

Scoring indicators

- (a) The different type of message signals are voice, music, picture and computer data.
 (b)

Column A	Column B
speech signals,	2.8 kHz
Music signals	20 kHz
Video signals	4.2 MHz
TV signal	6 MHz

Q.3**L.O:15.3****Question text**

The given figure shows the various propagation modes of e.m. waves for communication

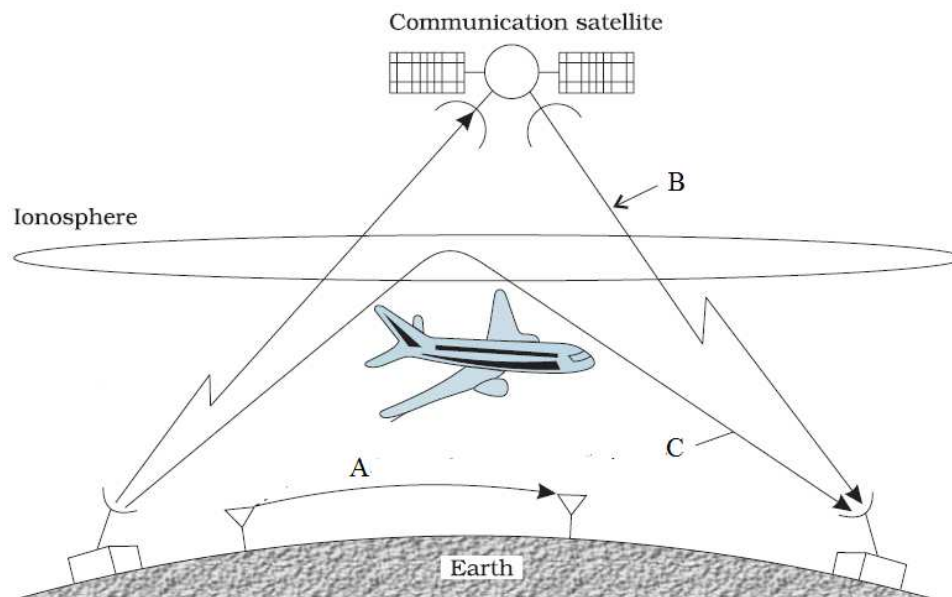

- (a) Identify the propagation modes in A, B, C
 (b) Why transmission of TV signals via sky wave is not possible?
 (c) A radio can tune to any station in 7.5 MHz to 12MHz. What is the corresponding wavelength band?

Scoring indicators

- (a) A –ground wave,B-space wave, and C – sky wave.
 (b) TV signals are in the range of 100 to 220MHz. Ionosphere cannot reflect these waves.
 (c)

Wave length corresponding to 100MHz is $\lambda = \frac{c}{f} = \frac{3 \times 10^8}{7.5 \times 10^6} = 40\text{m}$

Wave length corresponding to 220 MHz is $\lambda = \frac{c}{f} = \frac{3 \times 10^8}{12 \times 10^6} = 25\text{m}$

Thus the wavelength band is 25m to 40m.

Q.4

L.O:15.3

Question text

In the broadcast mode of communication, modulation is necessary.

- (a) What do you mean by modulation?
 (b) Why modulation is necessary?
 (c) What do you mean by modulation index in AM ?

Scoring indicators

- (a) Modulation is the process by which some characteristics, like amplitude, frequency or phase angle of a high frequency carrier wave is varied in accordance with the instantaneous value of the audio signal.
- (b) Modulation is necessary due to the following reasons
- (i) The height of the transmitting antenna should be at least $\frac{1}{4}$ th of the wave length. So to transmit audio frequency ,we need very long antenna.
 - (ii) The power radiated by an antenna is inversely proportional to the square of the wavelength. In audio frequency, wavelength is higher.
 - (c) It is the ratio of the change in amplitude of the modulated carrier wave to the amplitude of the original carrier wave.

Q.5

L.O:15.5

Question text

The given figure shows the frequency spectrum of an amplitude modulated wave.

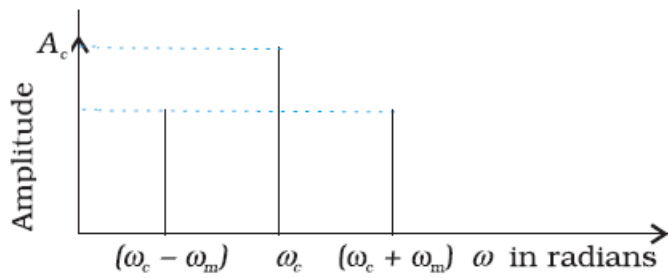

- (a) What are the names of $(\omega_c - \omega_m)$ and $(\omega_c + \omega_m)$
- (b) What is the value of amplitude of $(\omega_c - \omega_m)$, if modulation index is μ ?
- (c) What is the modulation index of AM, if the voltage amplitude of the carrier wave is 2kV and side band voltage amplitude is 200V.

Scoring indicators

- (a) Lower side band frequency and upper side band frequency
- (b) Value of the amplitude of the side band frequency is $A_s = \frac{\mu A_c}{2}$, where A_c is amplitude of carrier wave.

(c) $A_s = \frac{\mu A_c}{2}, \quad \mu = \frac{2A_s}{A_c} = \frac{2 \times 200}{2000} = 0.2$

ELECTROSTATIC POTENTIAL AND CAPACITANCE

Q1

LO : 1.10, 2.1, 2.3 and 2.4

Question Text

When a charged particle moves in an electric field, work is done on the particle.

- a) Pick out a vector quantity from the following
- | | |
|---------------------------------|----------------------------------|
| (i) electric potential | (ii) electric potential gradient |
| (iii) electric potential energy | (iv) electric flux |
- (1)
- b) 5 J of work is done in moving a positive charge of 0.5 C between two points. What is the potential difference between the points
- | | | | |
|-----------|-----------|-------------|------------|
| (i) 2.5 V | (ii) 10 V | (iii) 0.1 V | (iv) 5.5 V |
|-----------|-----------|-------------|------------|
- (1)
- c) Three point electric charges $q_1 = 6 \mu\text{C}$, $q_2 = 4 \mu\text{C}$ and $q_3 = -8 \mu\text{C}$ are placed on the circumference of a circle of radius 1 m as shown in the figure. What is the value of the charge q_4 placed on the circle if the potential at the centre of the circle is zero? (3)

Scoring Indicators :

- a) Electric potential gradient
- b) 10 V
- c) Radius of the circle $r = 1 \text{ m}$

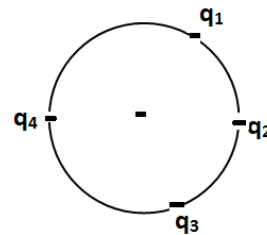

By the given condition

$$\frac{1}{4\pi\epsilon_0} \times \frac{1}{r} (q_1 + q_2 + q_3 + q_4) = 0$$

$$(q_1 + q_2 + q_3 + q_4) = 0$$

$$(6 + 4 - 8 + q_4) \mu\text{C} = 0$$

$$(2 + q_4) \mu\text{C} = 0$$

$$q_4 = -2 \mu\text{C}$$

Q2

LO : 2.5

Question Text

Equipotential surface is a surface on which the electric potential is the same at every point.

- “Electric field lines are always parallel to Equipotential surfaces”. Correct the statement if there is any mistake. (1)
- Draw the equipotentials for a single positive point charge. (2)
- A point charge $+q$ is placed at the centre of a sphere of radius R . Another point charge $+q$ is taken from a point A to another diametrically opposite point B on the surface of the sphere. Calculate the work done for this. (2)

Scoring Indicators :

- Electric field lines are always *perpendicular* to Equipotential surfaces

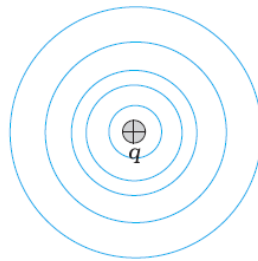

- Surface of the sphere is Equipotential in nature. So the potential difference between any points is zero. Since work done is the product of charge moving and the potential difference between the points, work done is equal to zero.

Q3

LO : 2.11, 2.12

Question Text

Capacitance of a capacitor depends on the size and shape of the conductors and on the dielectric material between them.

- Draw the symbol of a variable capacitor. (1)
- The plates of a parallel plate capacitor are connected to an ideal voltmeter. What will happen to the reading of the voltmeter if the plates of the capacitor are brought closer to each other in an insulating medium? (2)

- c) The plates of a parallel plate capacitor in vacuum are 5 mm apart and 1.5 m² in area. A potential difference of 10 kV is applied across the capacitor. Calculate
- (i) the capacitance
 - (ii) the charge on each plate
 - (iii) magnitude of the intensity of electric field between the plates.

Scoring Indicators :

a)



b) Capacitance $C = \frac{\epsilon_0 A}{d}$

$$\text{Potential difference } V = \frac{q}{C} = \frac{qd}{\epsilon_0 A}$$

In an insulating medium charge remains the same, voltage is directly proportional to plate separation.

Therefore, voltmeter reading decreases.

- c) (i) $C = \frac{\epsilon_0 A}{d} = \frac{8.85 \times 10^{-12} \times 1.5}{5 \times 10^{-3}} = 2.66 \times 10^{-9} F$
- (ii) $Q = CV = 2.66 \times 10^{-9} \times 10 \times 10^3 = 2.66 \times 10^{-5} C$
- (iii) $E = \frac{V}{d} = \frac{10 \times 10^3}{5 \times 10^{-3}} = 2 \times 10^6 Vm^{-1}$

Q4

LO :2.14

Question Text

Capacitors can be combined to obtain any desired capacitance in an application.

- a) You are given two capacitors of capacitance 20 μF each. Draw a diagram to show how you will connect these capacitors to get 40 μF capacitance. (1)
- b) Two capacitors C_1 and C_2 are connected in series. This combination is connected in parallel with a third capacitor C_3 .
 - (i) Draw a diagram of the above combination. (1)

- (ii) If $C_1 = 4 \mu\text{F}$, $C_2 = 6 \mu\text{F}$ and $C_3 = 2.4 \mu\text{F}$ and a potential difference of 100 V is applied across the combination calculate the charge stored in each capacitor.

(4)

Scoring Indicators :

a)

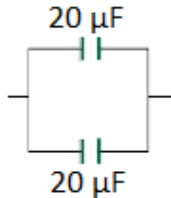

b)

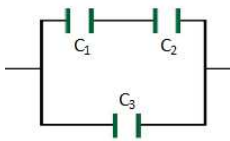

c) Effective capacitance of C_1 and C_2

$$C_{12} = \frac{C_1 C_2}{C_1 + C_2} = \frac{4 \times 6}{4 + 6} = 2.4 \mu\text{F}$$

Potential difference across $C_{12} = 100 \text{ V}$

Charge stored on C_{12} , $q_{12} = C_{12} \times 100$

$$q_{12} = 2.4 \times 10^{-6} \times 100$$

$$q_{12} = 2.4 \times 10^{-4} \text{ C}$$

Charge on C_1

$$q_1 = 2.4 \times 10^{-4} \text{ C}$$

Charge on C_2

$$q_2 = 2.4 \times 10^{-4} \text{ C}$$

Potential difference across $C_3 = 100 \text{ V}$

Charge on C_3

$$q_3 = C_3 \times 100$$

$$q_3 = 2.4 \times 10^{-6} \times 100$$

$$q_3 = 2.4 \times 10^{-4} \text{ C}$$

Q5

LO : 2.13, 2.14, 2.15

Question Text

Many of the applications of capacitors depend on their ability to store energy.

- a) In a charged capacitor energy is stored in the
 (i) positively charged plate (ii) negatively charged plate
 (iii) electric field between the plates (iv) none of these
 (1)
- b) Draw a graph showing the variation of charge stored in a capacitor with its potential. How will you calculate the energy stored in the capacitor using the above graph? (2)
- c) An electric flash lamp has 20 capacitors each of capacitance $5 \mu\text{F}$ connected in parallel. The lamp is operated at 100 V. If the energy stored in the combination is completely radiated out in a single flash, how much energy will be radiated in a flash?
 (2)

Scoring Indicators :

- a) Electric field between the plates

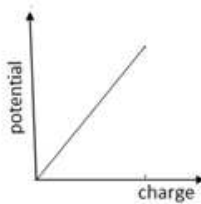

- b)

Area under the straight line graph gives the energy stored in the capacitor.

- c) Effective capacitance $C = 20 \times 5 \mu\text{F} = 100 \mu\text{F}$

$$\text{Energy stored } E = \frac{1}{2} CV^2$$

$$E = \frac{1}{2} \times 100 \times 10^{-6} \times 100^2 = 0.5 \text{ J}$$

CURRENT ELECTRICITY

Q1

LO : 3.5,3.6

Qn. Text.

The variation of resistivity (ρ) with temperature (T) of a conductor, semiconductor and super conductor are given in the figure.

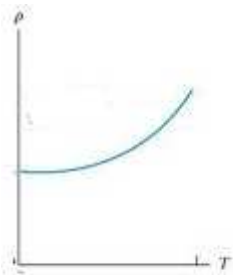

Fig i

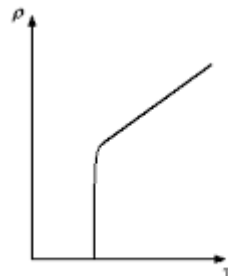

Fig ii

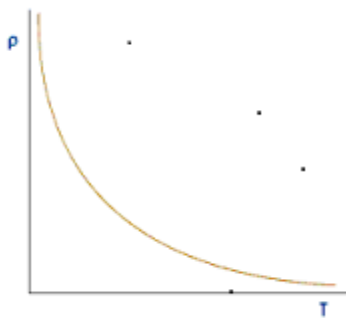

Fig iii

- Identify them from the graph. (1)
- Identify the figure in which the temperature coefficient of resistance of the material is positive. (1)
- Write the equation connecting resistivity of the material with relaxation time. (1)

Scoring Indicators:

- Fig(i) - Conductor
Fig (ii) - Superconductor
Fig(iii) - Semiconductor
- Fig (i)

c) We have resistivity(ρ) from equation

$\rho = \frac{m}{ne^2\tau}$, where τ is the relaxation time, m mass of electron, n number density of electron and e charge of electron.

Q2

L O : 3.2 , 3.5

Qn. Text:

The resistance value of a conductor depends on its physical dimensions.

a) Give the expression for resistance of a conductor in terms of its physical dimension.

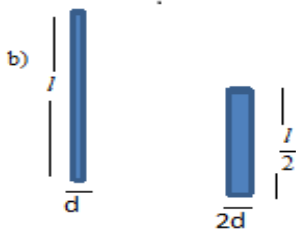

(l length and d diameter)

A potential V is applied between the ends of two conductor of same material shown in the figure.

i) Express the resistance of the second conductor in terms of the resistance of the first conductor.

ii) Find the ratio of electric field across the two conductors.

Score:

1+2+1

Scoring indicators:

a) $R = \rho \frac{l}{A}$

l – length of the conductor and

A – Area of cross section

b)

i) $R_1 = \rho \frac{l}{A} = \rho \frac{l}{\pi r^2} = \rho \frac{l}{\pi (d/2)^2} = \rho \frac{4l}{\pi d^2}$

$$R_2 = \rho \frac{l}{A} = R = \rho \frac{4l}{\pi d^2} = \rho \frac{4 \cdot l/2}{\pi (2d)^2} = \rho \frac{4l}{\pi 8d^2} = \frac{1}{8} \left(\rho \frac{4l}{\pi d^2} \right) = \frac{1}{8} R_1$$

$$\text{ii) } E_1 = \frac{V}{l_1}$$

$$E_2 = \frac{V}{l_2} = \frac{V}{(l/2)} = 2 \frac{V}{l} = 2E_1$$

$$\frac{E_1}{E_2} = \frac{E_1}{2E_1} = \frac{1}{2} = 1:2$$

Q3

L O : 3.8

Qn. Text.

Three resistors R_1, R_2, R_3 are to be combined as shown in the figure.

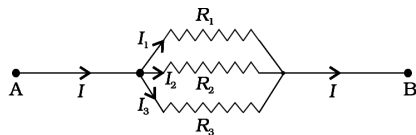
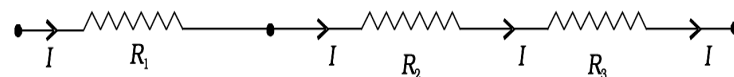

Fig (i)



Fig(ii)

- Identify the series and parallel combinations.
- Which combination has lowest resistance. Arrive at the expression for the effective resistance of this combination.
Score:1+3

Scoring Indicators

- Fig i) – parallel
Fig ii) – series
- Fig i).

Let V be the potential between A and B

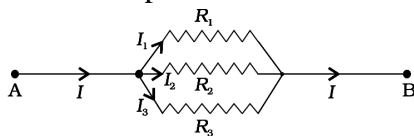

$$I = I_1 + I_2 + I_3$$

and applying Ohm's law to R_1, R_2 and R_3 we get,

$$V = I_1 R_1, V = I_2 R_2, V = I_3 R_3$$

So that

$$I = I_1 + I_2 + I_3 =$$

$$= V \left(\frac{1}{R_1} + \frac{1}{R_2} + \frac{1}{R_3} \right)$$

An equivalent resistance R_{eq} that replaces the combination, would be such that and hence

$$\frac{1}{R_{eq}} = \frac{1}{R_1} + \frac{1}{R_2} + \frac{1}{R_3}$$

Q 4

L.O: 3.8

Qn text.

An electric circuit is given in the Figure

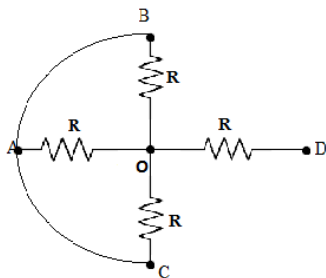

The potential difference between A and D is 40V.

- Find the effective resistance between A and D in terms of R.
- Calculate the potential difference between A and E. Score: 1+3

Scoring Indicators

- $$R_{eff} = \frac{R}{3} + R = 4\frac{R}{3}$$
- $$V_{AD} = V_{AO} + V_{OD}$$

But $V_{OD} = 3 V_{AO}$

$$\therefore V_{AD} = V_{AO} + 3 V_{AO}$$

$$40 = 4V_{AO}$$

$$V_{AO} = \frac{40}{4} = 10V$$

Q5

L O : 3.4, 3.7

Qn. Text.

When potential difference is applied between the ends of conductor the electrons will flow through the conductor with a constant average velocity.

- Name the velocity
- A potential 'V' is applied across a conductor of length 'l'. Keeping the potential difference same, the length of the conductor is halved. How does the velocity of electrons change?
- Write the colour code of the resistor of resistance $(540 \pm 10\%) \text{ M}\Omega$ Score :
1+2+1

Scoring Indicators:

- Drift velocity
- $$v = \frac{eE}{m} \tau$$

$$v = \frac{eV\tau}{ml} \text{ (since } E = \frac{V}{l} \text{)}$$

$$v' = \frac{eV\tau}{m l/2} = 2 \frac{eV\tau}{ml} = 2v \text{ . The drift velocity becomes twice the initial velocity.}$$
- Green, Yellow ,Violet ,Silver

Q6

LO : 3.15

Qn. Text.

A student was asked to compare the resistance of two conductors using a meter bridge apparatus.

- What is the working principle of Meter Bridge.
- Draw the necessary circuit diagram for the experiment.
- Write an expression for the ratio of resistances.
- A Meter bridge wire has resistance $0.2\Omega / \text{cm}$. The bridge is balanced at 60cm from the end of an unknown resistance X. If the known resistance is 2Ω , find the current flowing through the circuit in the balanced condition if a cell of 8V is connected in the circuit.

Score:1+2+1+2

Scoring Indicators:

- Wheatstone's Principle
-

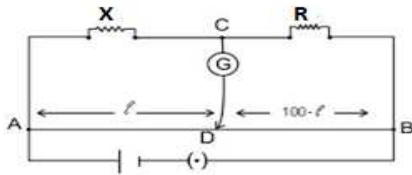

$$c) \quad \frac{X}{R} = \frac{l}{(100-l)}$$

- d) When the bridge is balanced R_{AD} , R_{DB} of the meter bridge are in series. Also R and X are in series.

Effective resistance of R_{AD} and $R_{DB} = 100 \times 0.2 = 20\Omega$

$$\frac{X}{R} = \frac{l}{(100-l)} = \frac{60}{40} = \frac{3}{2}$$

$$X = R \frac{3}{2} = 2 \times \frac{3}{2} = 3\Omega$$

Effective resistance of R and X in series = $R + X = 3 + 2 = 5\Omega$

$$\text{Effective resistance of the network} = \frac{20 \times 5}{(20 + 5)} = \frac{100}{25} = 4\Omega$$

$$\text{Current through the circuit } I = \frac{V}{R} = \frac{8}{4} = 2A$$

Q7

L O : 3.9,3.10

Qn. Text.

- Define electric power. What is its SI Unit?
- Two bulbs of 50W, 220V and 100W, 220V are given. How will you connect the bulbs so that 50W, 220V bulb will glow brighter than 100W, 220V bulb.
- When the bulb 50W, 220V is connected to an 110V supply calculate the power generated.

Score: 2+1+2

Scoring Indicators

- The energy dissipated per unit time is the power.

$$P = \frac{\Delta W}{\Delta t}$$

$$P = IV = I^2 R = \frac{V^2}{R}$$

Unit is watt

- In series.

$$c) \quad R = \frac{V^2}{P} = \frac{220^2}{50} = 968\Omega$$

Power generated while connecting 110V

$$P = \frac{V^2}{R} = \frac{110^2}{968} = 12.5W$$

Q8

L O : 3.2

Qn. Text.

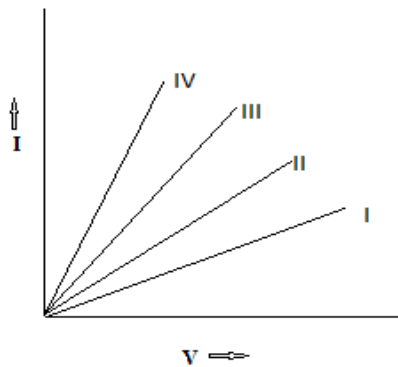

The figure shows the V-I characteristics of two resistors R_1 , R_2 and the effective resistance of the series and parallel combinations. ($R_1 > R_2$).

a) Identify from the graph whether these resistors are ohmic or non-ohmic?

b) Match the graphs with the corresponding resistances.

Score :1+

2

Scoring Indicators:

a) Ohmic conductors

b)

Resistance	Characteristic
R_1	II
R_2	III
R_1 and R_2 in series	I
R_1 and R_2 in parallel	IV

Q9

L O : 3.16

Qn. Text.

The Figure shows the diagram of a potentiometer.

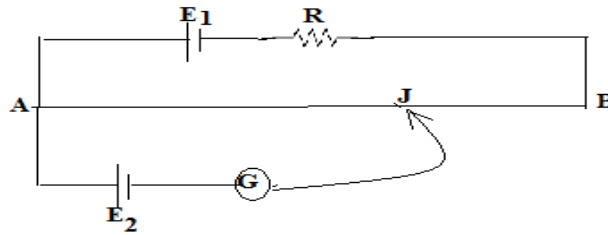

- Give the principle of a potentiometer.
- The length of AB is 3m and resistance per unit length of the potentiometer wire is $4\Omega/\text{m}$. If $E_1 = 4\text{V}$, $R = 20\Omega$ and $E_2 = 1\text{V}$ find the length of the potentiometer wire that balances E_2 .
- If $E_2 > E_1$ can we get the null deflection in galvanometer. Give reason. Score :1+3+2

Scoring Indicators

- When a constant current is flowing through a wire having uniform area of cross section and uniform composition the potential difference across any length of the wire is directly proportional to its length.

$$V \propto l$$

- The resistance of potentiometer

$$R_p = 4 \times 3 = 12\Omega$$

$$\text{current through the potentiometer } I = \frac{E}{R + R_p} = \frac{4}{20 + 12} = 0.125 \text{ A}$$

$$\text{Potential across potentiometer wire } V_{AB} = IR_p = 0.125 \times 12 = 1.5 \text{ V}$$

$$\text{Potential gradient } k = \frac{V_{AB}}{l} = \frac{1.5}{3} = 0.5 \text{ V/m}$$

Balancing length for cell E_2 is given from equation

$$E_2 = kl_2 = 0.5l_2$$

$$l_2 = \frac{E}{k} = \frac{1}{0.5} = 2\text{m}$$

- If $E_2 > E_1$ we will not get null deflection. The potential difference across the potentiometer wire AB should be higher than the emf of E_2 .

Q 10

LO : 3.14

Qn. Text.

The Figure shows the arrangement of five identical bulbs R_1, R_2, R_3, R_4 and R_5

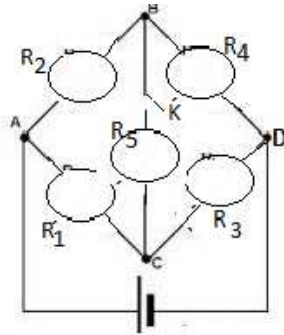

- a) When the switch is closed will all the bulbs glow? Give reason.
- b) Identify the underlying principle. Deduce the principle for a resistance network.

Score: 2+3

Scoring indicators:

- a) No. Since all the bulbs are identical the bridge is balanced. So potential at B and C is same and no current flows through the bulb connected between B and C. So all other bulbs except R_5 will glow.
- b) Wheatstone's principle.

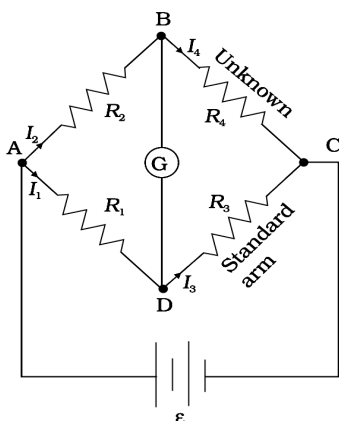

The bridge has four resistors R_1 , R_2 , R_3 and R_4 . A source is connected. There will be currents flowing through all the resistors as well as the galvanometer. In the case of a balanced bridge $I_g = 0$. Then

Kirchhoff's junction rule applied to junctions D and B gives

$$I_1 = I_3 \text{ and } I_2 = I_4.$$

we apply

Kirchhoff's loop rule to closed loops ADDBA .

$$-I_1R_1 + 0 + I_2R_2 = 0 \quad (I_g = 0)$$

The loop CBDC gives,

$$-I_1R_3 + 0 + I_2R_4 = 0$$

$$I_2 R_4 = I_1 R_3$$

$$\frac{I_1}{I_2} = \frac{R_4}{R_3}$$

$$I_3 = I_1, I_4 = I_2$$

we obtain,

$$\frac{I_1}{I_2} = \frac{R_2}{R_1}$$

and,

$$\frac{I_1}{I_2} = \frac{R_4}{R_3}$$

Hence, we obtain the condition

$$\frac{R_2}{R_1} = \frac{R_4}{R_3}$$

Q11

LO : 3.13

Qn. Text.

- a) Kirchhoff's second law is a consequence of
- Law of conservation of angular momentum
 - Law of conservation of energy
 - Law of conservation of charge
 - None of these.
- b) Find the potential difference across the resistance 2Ω in the given network.

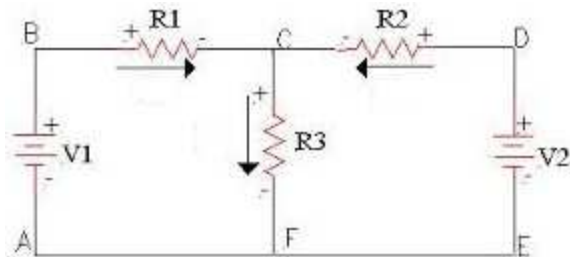

$$R_1 = 5\Omega, R_2 = 1\Omega, R_3 = 2\Omega$$

$$V_1 = 2V, V_2 = 4V$$

Score: 1+3

Scoring key:

- a) ii) Law of conservation of energy.
b)

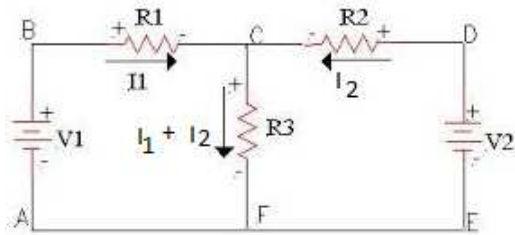

In loop ABCFA

$$2 + -5I_1 - (I_1 + I_2)2 = 0$$

$$-7I_1 - 2I_2 = -2$$

$$7I_1 + 2I_2 = 2 \dots\dots\dots (1)$$

In loop CDEFC

$$1I_2 + -4 + (I_1 + I_2)2 = 0$$

$$2I_1 + 3I_2 = 4 \dots\dots\dots (2)$$

$$7I_1 + 2I_2 = 2 \dots\dots\dots (1)$$

$$2I_1 + 3I_2 = 4 \dots\dots\dots (2)$$

Or

$$21I_1 + 6I_2 = 6 \dots\dots\dots (3)$$

$$4I_1 + 6I_2 = 8 \dots\dots\dots (4)$$

$$(4) - (3) ;$$

$$-17 I_1 = 2$$

$$I_1 = -2/17A$$

From (2)

$$2I_1 + 3I_2 = 4$$

$$2(-2/17) + 3I_2 = 4$$

$$-4/17 + 3 I_2 = 4$$

$$I_2 = 24/17 A$$

Current through $R_3 = 2\Omega$

$$I = I_1 + I_2 = (-2/17) + (24/17) = 22/17 A$$

Potential across $R_3, 2\Omega$ is

$$V = I R_3 = 2 \times (22/17) = (44/17) V$$

Q 12

LO : 3.12 , 3.11

Qn. Text.

- a) State whether the following statement is correct.

“If the current through the cell is from its positive to negative, against the direction of emf, then the potential drop across the internal resistance aids the emf of the cell.”

- b) You are given two cells. Group them so that they give more voltage. Arrive at the expression for effective emf and internal resistance. Score: 1+3

Scoring Indicators:

- a) True. Internal resistance and lost volt always opposes current flow through the cell.

- b)

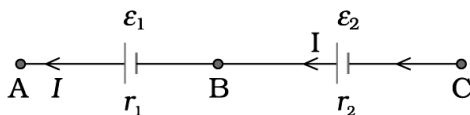

Consider two cells in series

ϵ_1, ϵ_2 are the emf's of the two cells and r_1, r_2 their internal resistances, respectively.

Let $V(A), V(B), V(C)$ be the potentials at points A, B and C shown in Fig. Then $V(A) - V(B)$ is the potential difference between the positive and negative terminals of the first cell.

$$V_{AB} \equiv V(A) - V(B) = \epsilon_1 - I r_1$$

Similarly,

$$V_{BC} \equiv V(B) - V(C) = \epsilon_2 - I r_2$$

Hence, the potential difference between the terminals A and C of the combination is

$$\begin{aligned} V_{AC} &\equiv V(A) - V(C) = [V(A) - V(B)] + [V(B) - V(C)] \\ &= (\epsilon_1 + \epsilon_2) - I(r_1 + r_2) \end{aligned}$$

$$V_{AC} = \epsilon_{eq} - I r_{eq}$$

Comparing the last two equations, we get

$$\epsilon_{eq} = \epsilon_1 + \epsilon_2$$

$$\text{and } r_{eq} = r_1 + r_2$$

MOVING CHARGES AND MAGNETISM

Q1

LO:4.2,4.1,4.3

Qn Text

When a current carrying conductor is placed in a magnetic field it experiences a force.

- a) Arrive at the expression for the force experienced by the conductor.
- c) A conductor carrying current I directed out of the plane of the paper is lying in the magnetic field as in Fig. Draw the direction of force experienced by the conductor.

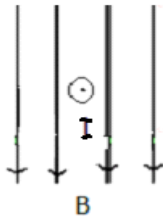

- d) If the conductor is lying parallel to the field what will be the force? Score:
2+1+ 1

Scoring indicators

- a) Consider a rod of a uniform cross-sectional area A and length l . Let the number density of these mobile charge carriers in it be n . Then the total number of mobile charge carriers in it is $n l A$. In the presence of an external magnetic field \mathbf{B} , the force on these carriers is:

$$\mathbf{F} = (n l A) q \mathbf{v}_d \times \mathbf{B}$$

Where q is the value of the charge on a carrier. $n q v_d$ is the current density \mathbf{j} and $|(n q v_d) A|$ is the current I

$$\begin{aligned} \mathbf{F} &= [(n q \mathbf{v}_d) l A] \times \mathbf{B} = [\mathbf{j} A l] \times \mathbf{B} \\ &= I \mathbf{l} \times \mathbf{B} \end{aligned}$$

c)

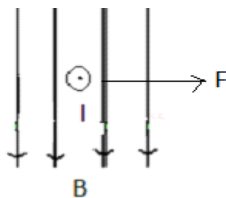

- d) Zero.

$$F = I \mathbf{l} \times \mathbf{B} = I l B \sin \theta = I l B \sin 0 = 0$$

Q2

Qn.Text:

A proton ,an electron ,a neutron and an alpha particle are entering a region of uniform magnetic field with same velocities . The tracks of these particles are labelled.

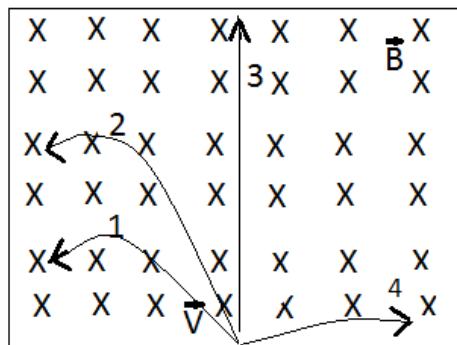

- Identify the tracks of each particle.
- Write the expression for the force experienced by a charged particle in the magnetic field in vector form.
- If a proton is moving at 90° to the uniform magnetic field what will be the change in kinetic energy of the proton? Give reason.
- An electron with energy 1keV is entering a uniform magnetic field of 0.04T at an angle 60° with the field. Predict the path of the electron and find the characteristics of the path.

Score: 2+1+2+2

Scoring Indicators

- Path 1- proton
 - Path 2- alpha particle
 - Path 3- neutron
 - Path 4- electron
- $\vec{F} = q \left(\vec{v} \times \vec{B} \right)$
- Zero. Since the force is perpendicular to the direction of velocity work done is zero.
- $KE = 1\text{keV} = 1 \times 10^3 \times 1.6 \times 10^{-19} = 1.6 \times 10^{-16}$

$$\frac{1}{2}mv^2 = 1.6 \times 10^{-16} \text{ J}$$

$$v^2 = \frac{1}{m} \times 1.6 \times 10^{-16} \times 2 = \frac{3.2 \times 10^{-16}}{9.1 \times 10^{-31}} = 0.352 \times 10^{15} = 3.52 \times 10^{14}$$

$$v = \sqrt{3.52 \times 10^{14}} = 1.88 \times 10^7 \text{ ms}^{-1}$$

$$\text{Radius of the path} = \frac{mv \sin \theta}{qB} = \frac{9.1 \times 10^{-31} \times 1.88 \times 10^7 \times \frac{\sqrt{3}}{2}}{1.6 \times 10^{-19} \times 0.04} = 2.31 \times 10^{-3} \text{ m}$$

$$\text{Pitch} = \frac{2\pi mv \cos \theta}{qB} = \frac{2 \times \pi \times 9.1 \times 10^{-31} \times 1.88 \times 10^7 \times 0.5}{1.6 \times 10^{-19} \times 0.04} = 8.39 \times 10^{-3} \text{ m}$$

Q3**Qn Text;**

A long straight conductor carrying current is placed near a current carrying circular loop as in the figure.

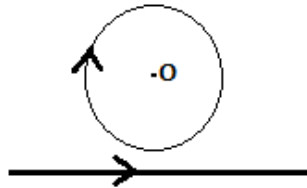

- If B_1 is the field of the ring and B_2 the field due to straight conductor what will be the direction of B_1 and B_2 at O.
- The current through the loop and the conductor are 2A and the conductor is at a distance 20cm from the centre of loop. What should be the diameter of the loop so that the net field at O is zero.

Score:1+3

Scoring Indicators:

- B_1 into the plane and B_2 out of the plane.
- B_1 is the field of the ring and B_2 the field due to straight conductor

$$B = B_1 - B_2 = 0$$

$$B_1 = B_2$$

$$\frac{\mu_0 I}{2a} = \frac{\mu_0 I}{2\pi d}$$

$$\frac{2}{2a} = \frac{2}{2 \times \pi \times 20 \times 10^{-2}}$$

$$2a = 40\pi \times 10^{-2} \text{ m} = 1.256 \text{ m}$$

$$\text{Diameter } d = 1.256 \text{ m}$$

Q 4**Qn Text**

A current carrying conductor is bent in the form of a circular ring and is placed in the plane of the paper.

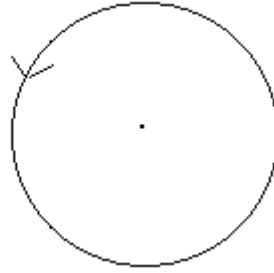

- What is the direction of the magnetic field at the centre of the ring ?
- Arrive at the expression for the magnetic field at a point on the axis of the ring.
- Another identical ring carrying the same current is brought with its axis perpendicular to the axis of the first as in figure. Find the magnetic field at the common centre. Calculate the angle between the net magnetic field and the axis of any one of the coils.
Score 1+3+2

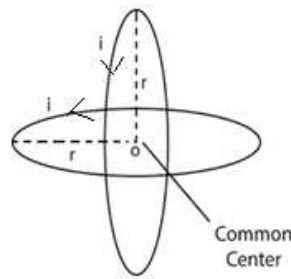

Scoring indicators:

- Out of the plane of the ring.
-

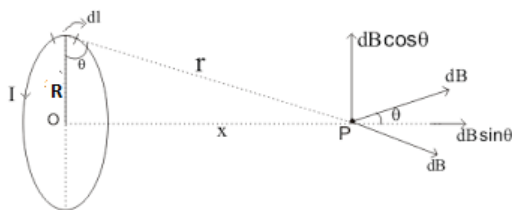

A circular loop carrying a steady current I . The loop is placed in the y - z plane with its centre at the origin O and has a radius R . The x -axis is the axis of the loop. We wish to calculate the magnetic field at the point P on this axis. Let x be the distance of P from the centre O of the loop.

Consider a conducting element dl of the loop. The magnitude dB of the magnetic field due to dl is given by the Biot-Savart law

$$dB = \frac{\mu_0}{4\pi} \frac{I |d\mathbf{l} \times \mathbf{r}|}{r^3}$$

$$r^2 = x^2 + R^2$$

$$|d\mathbf{l} \times \mathbf{r}| = r dl$$

$$dB = \frac{\mu_0}{4\pi} \frac{Idl}{(x^2 + R^2)}$$

It is perpendicular to the plane formed by dl and r . It has an x -component dB_x and a component perpendicular to x -axis, dB_{\perp} . When the components perpendicular to the x -axis are summed over, they cancel out. The net contribution along x -direction can be obtained by integrating

$dB_x = dB \cos\theta$ over the loop.

$$\cos\theta = \frac{R}{(x^2 + R^2)^{1/2}}$$

$$dB_x = \frac{\mu_0 Idl}{4\pi} \frac{R}{(x^2 + R^2)^{3/2}}$$

The summation of elements dl over the loop yields $2\pi R$, the circumference of the loop. Thus, the magnetic field at P due to entire circular loop is

$$\mathbf{B} = B_x \hat{\mathbf{i}} = \frac{\mu_0 I R^2}{2(x^2 + R^2)^{3/2}} \hat{\mathbf{i}}$$

At the centre of the loop. Here $x = 0$, and we obtain

$$\mathbf{B}_0 = \frac{\mu_0 I}{2R} \hat{\mathbf{i}}$$

c) magnetic fields are as shown in the fig,

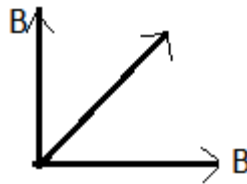

The diagonal gives the resultant field. $B' = \sqrt{B^2 + B^2} = \sqrt{2}B$

$$\tan\theta = \frac{B}{B} = 1$$

$$\theta = 45^\circ$$

Q 5

LO:4.3, 4.4

Qn Text;

A charged particle is travelling as in the figure.

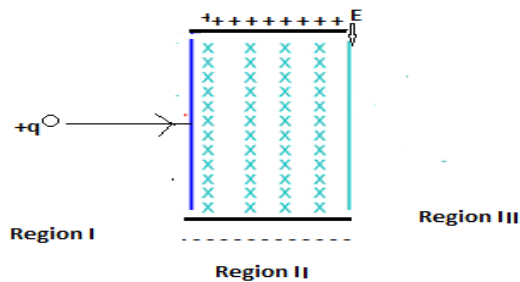

- Name the force experienced by the charge in the region II.
- Give the expression for the net force experienced by the charge in the region II.
- If the charge reaches the region III without any change in its initial direction of motion find the velocity of the charged particle in terms of E and B . Score:
1+1+2

Scoring Indicators:

- Lorentz Force
- $\mathbf{F} = q(\mathbf{E} + \mathbf{v} \times \mathbf{B})$
- Electric and magnetic fields are perpendicular to each other and also perpendicular to the velocity of the particle. If the total force on the charge is zero and the charge will move in the fields undeflected. This happens when

$$qE = qvB \quad \text{or} \quad v = \frac{E}{B}$$

Q 6

LO:

Qn Text:

An electron revolving round the nucleus acts as a magnetic dipole.

- Which force provides the centripetal force for electron?
- Write the expression for the magnetic dipole moment of electron in vector form. What is the angle between direction of the magnetic moment and direction of angular momentum?
- A charge 2mC is moving through a circular path of radius 0.15m with frequency 100Hz . Find the magnetic moment associated with the charge path.

Score:

1+2+2

Scoring indicators:

- Electrostatic force between electron and the nucleus
- Vectorially

$$\vec{\mu}_l = \frac{-e}{2m_e} \vec{l}$$

The magnetic moment of the electron is opposite in direction to the angular momentum.

$\therefore \text{Angle} = 180^\circ$

- c) Revolving charge behaves as a current loop. Hence Magnetic field is given as

$$B = \frac{\mu_0 I}{2 a}$$

$$I = \frac{q}{T} = qv = 2 \times 10^{-3} \times 100 = 0.2 A$$

$$\text{Magnetic moment} = IA = 0.2 \times \pi \times 0.15^2 = 0.0141 A m$$

Q 7

Qn Text;

A student placed a rectangular loop carrying current in between the pole pieces of two magnets and found that the loop is rotating.

- What is the net force on the loop?
- Write the expression for the torque experienced by the loop in vector form.
- At what position will the coil be in stable equilibrium?
- A wire of length 4m is bent in the form of a circular coil of single turn. A current 1A is flowing through the wire. If the coil is placed in a magnetic field of 0.4T find the maximum torque experienced by the coil. Score:1+1+1+2

Scoring Indicators:

- Zero.
- $\vec{\tau} = NI\vec{A} \times \vec{B} = \vec{m} \times \vec{B}$
- $\theta = 0, \tau = 0$.
(Area vector of the coil is parallel to the direction of magnetic field).
 - Potential energy minimum.

- d) $l = 4m$

$$2\pi r = 4$$

$$r = \frac{4}{2\pi}$$

$$\text{Area} = A = \pi r^2$$

$$\text{Maximum torque} = NIAB = 1 \times 1 \times \pi \left(\frac{4}{2\pi} \right)^2 \times 0.4 = 0.509 Nm$$

Q 7

LO : 4.14, 4.15

Qn Text:

You are supplied with a galvanometer, resistor and some connecting wires.

- a) Using a circuit diagram, show how will you convert the given galvanometer into an ammeter
- b) Find the expression for the shunt resistance in the circuit.
- c) A galvanometer is to be converted into an ammeter of range 0-1A. Galvanometer has resistance 100Ω and the current for full scale deflection is 10mA . Find the length of the nichrome wire to be used as shunt.
 Given, Resistivity $\rho = 1.1 \times 10^{-6} \Omega\text{m}$.
 Diameter of the wire = 1mm
- Score;
- 1+2+3

Scoring Indicators

a)

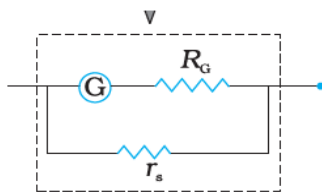

- b) Let I_g be the current through the galvanometer of resistance R_G and the shunt resistance be r_s .

Let I be the current to be measured by the converted ammeter.

We can write,

$$I_g R_G = (I - I_g) r_s$$

$$\therefore r_s = \frac{I_g R_G}{(I - I_g)}$$

- c) Given $I = 1\text{A}$

$$I_g = 10\text{mA}$$

$$R_G = 100\Omega$$

$$\text{Diameter} = 1\text{mm}$$

$$\therefore r_s = \frac{I_g R_G}{(I - I_g)} = \frac{10 \times 10^{-3} \times 100}{(1 - 0.01)} = 1\Omega$$

$$r_s = \frac{\rho l}{\pi r^2}$$

$$l = \frac{r_s \pi r^2}{\rho} = \frac{1 \times 3.14 \times (0.50 \times 10^{-3})^2}{1.1 \times 10^{-6}} = 0.714\text{m}$$

Q 8

Qn .Text:

Ampere's theorem helps to find the magnetic field in a region around a current carrying conductor.

- a) Write the expression for Ampere's theorem.

- b) Draw the variation of intensity of magnetic field with the distance from the axis of a current carrying conductor.
- c) A conductor carrying a current I is bent as shown in the figure. Apply Ampere's theorem at the regions 1 and 2 shown in the figure.

Score : 1+1+3

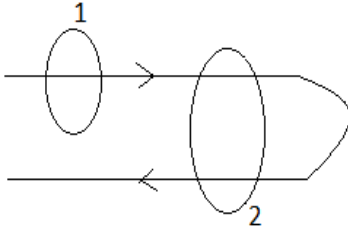

Scoring Indicators

a)

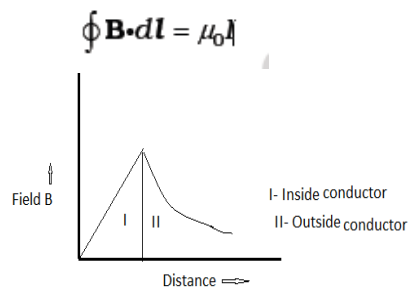

b) Region 1

$$\oint \mathbf{B} \cdot d\mathbf{l} = \mu_0 I$$

Region 2

$$\oint \mathbf{B} \cdot d\mathbf{l} = 0$$

MAGNETISM AND MATTER

Q 1

L.O : 5.1

Qn.Text

Magnetic field lines are the visualization of magnetic field.

- a) Write any three properties of magnetic field lines.
- b) The arrangement shows two bar magnets placed near each other. Draw the magnetic field lines of the system.

Score:2+1



Scoring indicators:

- a) i) Magnetic lines of force originate from north pole and are directed to south outside a magnetic material.
- ii) The lines form closed loops.
- iii) Two lines of force never intersect each other, if they did, the direction of the magnetic field would not be unique at the point of intersection.
- iv) The tangent to the field line at a given point represents the direction of the net magnetic field B at that point.

b)

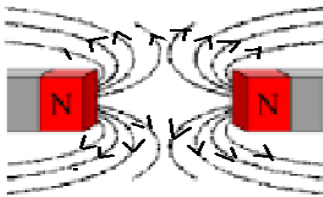

Q 2

L.O:5.5

Qn.Text

The figure shows the magnetic field of earth.

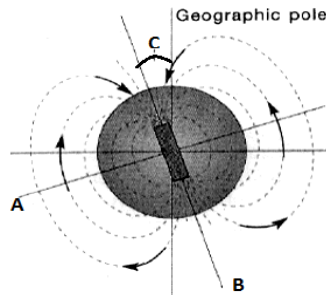

- Identify the labels, A, B, C.
- The lines drawn on a map through places that have the same declination are called.....
- The horizontal component of earth's magnetic field at a place is $0.25 \times 10^{-4} \text{T}$ and the resultant magnetic field is $0.5 \times 10^{-4} \text{T}$. Find the dip and the vertical component of the earth's magnetic field at the place.

Score:1+1+2

Scoring Indicators:

- A- Magnetic equator
B- Magnetic axis
C- Declination
- Isogonic lines
- Horizontal component of earth's magnetic field is

$$B_H = B \cos \delta$$

$$0.25 \times 10^{-4} = 0.5 \times 10^{-4} \cos \delta$$

$$\delta = 60^\circ$$

Vertical component of earth's magnetic field is

$$B_V = B \sin \delta = 0.5 \times 10^{-4} \sin 60 = 0.43 \times 10^{-4} \text{T}$$

Q 3

L.O:5.3,5.4,5.5

Qn.Text

Match the following

Score:4

	A	B	C
i	Gauss's theorem	$U = -(M \cdot B)$	Am^{-1}
ii	Dip	Magnetic dipoles	$\int B \cdot ds = 0$
iii	$I = \frac{m}{A}$	90°	Potential energy minimum when magnetic moment is parallel to the field
iv	Potential energy of magnetic dipole	Intensity of magnetisation	North pole of a freely suspended magnet points down
			Neutral point

Scoring indicators:

	A	B	C
i	Gauss's theorem	Magnetic dipoles	$\int B \cdot ds = 0$
ii	Dip	90°	North pole of a freely suspended magnet points down
iii	$I = \frac{m}{A}$	Intensity of magnetisation	Am^{-1}
iv	Potential energy of magnetic dipole	$U = -(M \cdot B)$	Potential energy minimum when magnetic moment is parallel to the field

Q 4

L.O:5.6,5.7

Qn.Text

The figure shows a liquid placed on the pole pieces of two magnets.

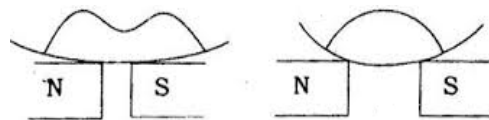

- Which magnetic behaviour is exhibited by the liquid?
- Write any two characteristics of this magnetic behaviour?
- Does this behaviour transform with temperature. Why?

Score:1+2+2

Scoring indicators:

- Diamagnetism
- When a diamagnetic material is placed in a non-uniform magnetic field it moves from the stronger to weak field.
 - When a diamagnetic material is placed in a magnetic field the field lines are expelled from the material.
 - When a diamagnetic rod is suspended freely in a uniform magnetic field, the rod aligns itself in a direction perpendicular to the magnetic field.
 - Permeability of a diamagnetic material is less than one.
 - Susceptibility is small and negative.
- No. The magnetic dipole moment induced in the diamagnetic material is opposite to the magnetising field and hence does not affect the thermal motion of atoms. Hence change in temperature has no effect on diamagnetism.

Q 5

L.O:5.3

Qn.Text

When a magnetic needle is placed in a non-uniform magnetic field it experiences

- a) i) a force but no torque ii) a torque but no force iii) Force and torque iv) neither a force nor a torque.
- b) A bar magnet held perpendicular to a uniform magnetic field as in the figure. If the torque acting on it is to be reduced to $1/4^{\text{th}}$ by rotating the magnet towards the direction of the field, find the angle through which the magnet is to be rotated.

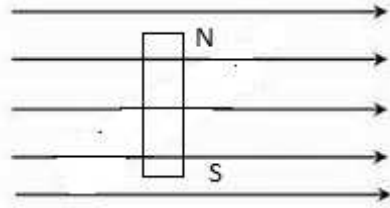

- c) State whether the potential energy of the magnet increases or decreases after rotation. Justify your answer.

Score:1+2+2

Scoring Indicators:

- a) iii) force and torque
- b) When the bar magnet is perpendicular to the field

Torque is maximum

$$\tau = MB \sin \theta = MB \sin(90) = MB$$

When rotated through an angle θ

Torque is

$$\frac{\tau}{4} = MB \sin \theta$$

$$\frac{\tau}{(\tau/4)} = \frac{MB}{MB \sin \theta}$$

$$4 = \frac{1}{\sin \theta}$$

$$\theta = \sin^{-1}\left(\frac{1}{4}\right) = 14.47^\circ$$

Angle through which the magnet is to be rotated is $90 - \theta = 75.53^\circ$

- c) Potential energy decreases.

Potential energy is minimum when the magnet is parallel to the field. $U = -MB \cos \theta$ When rotated to 0° (to make magnet parallel to the field) Potential energy decreases.**Q 6**

L.O:5.8,5.9,5.10

Qn.Text

The figure shows hysteresis curves for soft iron and steel.

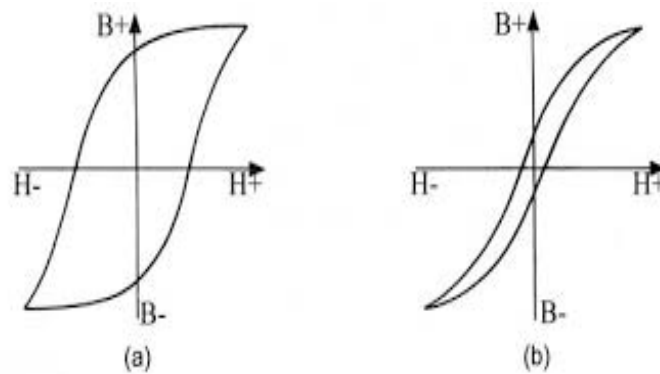

- Which among the two is the hysteresis loop of soft iron?
- Which one among the two materials is preferred for use in transformers and galvanometers?
- When steel is once magnetized, the magnetization is not easily destroyed even if it is exposed to stray reverse fields. Give reason.

Score:1+1+2

Scoring Indicators:

- Fig.b
- Soft iron
- When steel is magnetised the magnetic domains in the material is permanently set and magnetised permanently in the direction of the applied magnetic field.

ELECTROMAGNETIC INDUCTION

Q1.

LO : 6.3, 6.4

Question Text

A boy is riding a bicycle with its dynamo on. when he increases the speed, the brightness of the bulb connected to the dynamo increases

- State the law used to explain the above phenomenon. (2)
- Which law helps you to find the direction of current induced in the loop ? (1)
- The magnetic flux through a coil is $\phi = (5t^2 + 6t + 9)$ Wb. Find the ratio of emf at $t = 3$ s to $t = 0$ s (2)

Scoring Indicator

- Statement of Faraday's law
- Lenz's law
- $\epsilon = \frac{d\phi}{dt}$

$$\text{At } t = 3 \text{ s} \quad \epsilon_{(3)} = 10 \times 3 + 6 = 36\text{V}$$

$$\text{At } t = 0 \text{ s} \quad \epsilon_{(0)} = 10 \times 0 + 6 = 6\text{V}$$

$$\frac{\epsilon_{(3)}}{\epsilon_{(0)}} = \frac{36}{6} = 6$$

Q2.

L.O : 6.5

Question Text

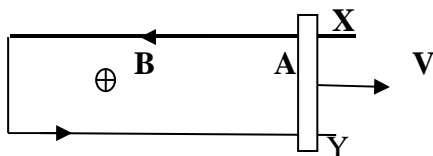

A conductor XY is moving through a uniform magnetic field of intensity B as shown in figure

- Name the emf ? (1)
- The motion of XY towards right side causes an anticlockwise induced current. What will be the direction of magnetic induction in the region A ? (1)

- c) The length of the conductor XY is 20cm. It is moving with a velocity 50m/s. perpendicular to the magnetic field. If the induced emf in the conductor is 2V. Find the magnitudes of magnetic field ?
(2)

Scoring Indicators

- a) Motional emf / induced emf
b) Applying right hand grip rule at A direction of magnetic field is away from the paper
c) $\varepsilon = Blv\sin\theta$

$$B = \frac{\varepsilon}{lv\sin\theta} = \frac{2}{2 \times 10^{-2} \times 50 \times \sin 90} = 0.2 \text{ T}$$

Q 3.

LO : 6.6

Question Text

Eddy current produced in rails causes smooth breaking of magnetic braking system in trains

- a) How eddy current is produced ? (2)
b) Explain the following with reason
(i) Laminated cores are used in transformers
(ii) Fixed core made of non- magnetic material is used in galvanometers (3)
c) The bob of a simple pendulum is replaced by a magnet and is allowed to oscillate along its length. If a short circuited coil is added so that one pole of the magnet passes in and out of it. What happens to the oscillation of magnet? Explain

(2)

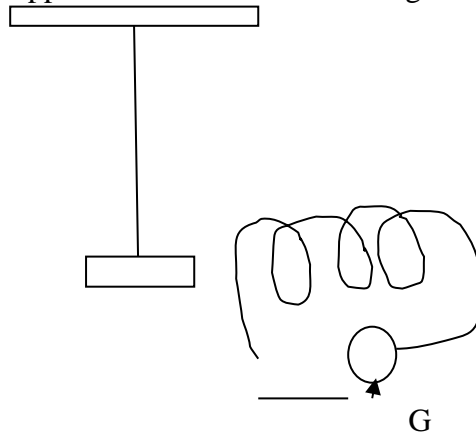
**Scoring Indicators**

- (a) Whenever the magnetic flux linked with the rails (metal piece) changes eddy current is produced
(b)(i) To reduce eddy current and hence to minimise the wastage of energy in the form of heat
(ii) Eddy current produced in the core helps for damping
(c) Eddy current produced in the coil opposes the motion of magnet hence damping occurs

Q4.

LO : 6.7

Question Text

Inertia of the circuit is the cause of self inductance of a coil

- a) SI unit of self inductance is
 (i) Henry (ii) Farad (iii) Volt (iv) Volt/ meter (1)
- b) What happens to the value of L of the coil when the no of turns is doubled keeping all other parameters constant ?
 (1)
- c) An induced emf of 4V is generated when the current in the circuit changes from 3 A to 4A in one millisecond. What is the self inductance of the coil (2)
- d) A bar magnet is allowed to fall freely through a solenoid whose ends are connected to each other. Does its acceleration is less than g ? Justify your answer
 (2)

Scoring Indicators

- a) Henry
- b) $L = \frac{\mu_0 n^2 A}{l}$
 When N is doubled L becomes four times
- c) $\epsilon = \frac{d\phi}{dt}$
 $= L \frac{di}{dt}$
 $L = \frac{\epsilon}{di/dt} = \frac{4}{\frac{1}{1 \times 10^{-3}}} = 4 \times 10^{-3} \text{ H}$
- d) Acceleration is less than g. According to lenz's law the upper face of the ring has same polarity as that of the pole pointing to it. Hence motion of the magnet is opposed

Q5.

LO : 6.8

Question Text

AC generator is a device based on electromagnetic induction used to convert mechanical energy in to electrical energy

- a) Draw a graph showing variation of induced emf over a cycle. Also indicate peak value of emf ?
 (2)
- b) How peak value of emf is related to its rms value ? (1)
- c) A rectangular wire loop of side 4cmX6cm has 50 turns uniformly from 0.1 Tesla to 0.3 Tesla in 6×10^{-2} second. Calculate induced emf in the coil
 (2)

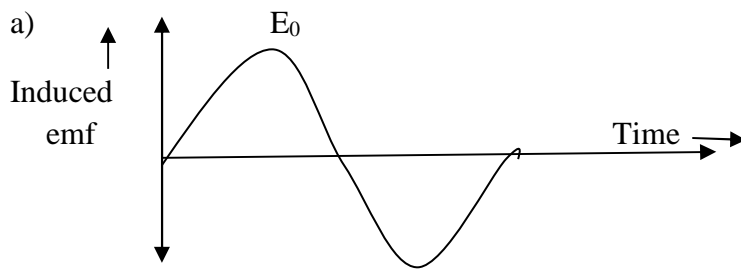
Scoring Indicators

b) $E_{rms} = \frac{E_0}{\sqrt{2}}$

c) $\epsilon = - \frac{d\phi}{dt} = - \left(\frac{\phi_1 - \phi_2}{t} \right)$

and $\phi = BAN$

$\theta_1 = 0.1 \times (24 \times 10^{-4}) \times 50 = 120 \times 10^{-4} \text{wb}$

$\theta_2 = 0.3 \times (24 \times 10^{-4}) \times 50 = 360 \times 10^{-4} \text{wb}$

$\epsilon = - \left(\frac{120 \times 10^{-4} - 360 \times 10^{-4}}{6 \times 10^{-2}} \right) = 40 \times 10^{-2} \text{ V}$

Q.6.

LO: 6.3, 6.5, 6.7

Question Text

Match the following

(2)

A	B
a. Lenz's law	Blv
b. Energy stored in an inductor	$\frac{d\phi}{dt}$
c. Motional emf	Electrical Inertia
d. Inductance	$\frac{1}{2} LI^2$
	$\frac{1}{2} CV^2$

Scoring Indicator

A	B
a. Lenz's Law	$-\frac{d\phi}{dt}$
b. Energy stored in an Inductor	$\frac{1}{2} LI^2$
c. Motional emf	Blv
d. Inductance	Electrical Inertia

ALTERNATING CURRENT CIRCUITS

Q1

LO : 7.1

Question Text

An alternating voltage is shown in figure. Answer the questions based on the voltage shown.

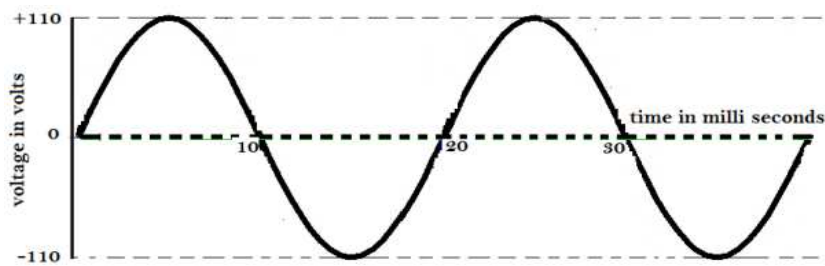

- What is the peak value of voltage? (1)
- What is the rms value of the voltage? (2)
- What is the frequency of the voltage? (1)
- Write the general equation of the voltage. (2)

Scoring Indicators

- 110 V
- $V_{rms} = \frac{V_m}{\sqrt{2}} = \frac{110}{\sqrt{2}} = 77.78 \text{ V}$
- Time period $T = 20 \text{ ms}$
Frequency $f = \frac{1}{T} = \frac{1}{20 \times 10^{-3}} = 50 \text{ Hz}$
- $v = v_m \sin \omega t$
 $v = 110 \sin(2\pi f)t$
 $v = 110 \sin(2\pi \times 50)t$
 $v = 110 \sin 314t \text{ volt}$

Q2

LO : 7.1.

Question Text

A voltage source is connected to an electrical component X as shown in figure.

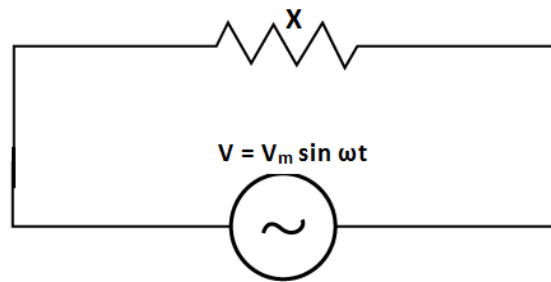

- a) Identify the device X. (1)
- b) Which of the following equations can represent the current through the circuit?
 (i) $i = i_m \sin(\omega t + \pi/2)$ (ii) $i = i_m \sin(\omega t - \pi/2)$
 (iii) $i = i_m \sin \omega t$ (iv) $i = i_m \sin(\omega t + \pi/4)$
 (1)
- c) Draw the phasor diagram for the circuit. (2)

Scoring Indicators

- a) Resistor
 b) $i = i_m \sin \omega t$

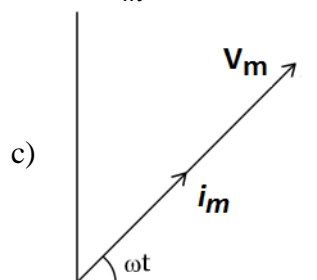
**Q3**

LO : 7.2

Question Text

The current through fluorescent lights are usually limited using an inductor.

- a) Obtain the relation $i = i_m \sin(\omega t - \pi/2)$ for an inductor across which an alternating emf $v = v_m \sin \omega t$ is applied. (2)
- b) Why it is better to use an inductor rather than a resistor to limit the current through the fluorescent lamp? (1)
- c) When 100 V DC source is connected across a coil a current of 1 A flows through it. When 100 V, 50 Hz AC source is applied across the same coil only 0.5 A flows. Calculate the resistance and inductance of the coil. (3)

Scoring Indicators

- a) Let an alternating voltage of the form $v = v_m \sin \omega t$ is applied to a pure inductor of inductance L . The back emf produced across the inductor is $-L \frac{di}{dt}$.

Using Kirchoff's second law

$$v - L \frac{di}{dt} = 0 \quad v = L \frac{di}{dt} \quad di = \frac{v}{L} dt$$

$$di = \frac{v_m}{L} \sin \omega t dt \quad \int di = \frac{v_m}{L} \int \sin \omega t dt \quad i = \frac{v_m}{L\omega} (-\cos \omega t)$$

$$i = \frac{v_m}{L\omega} \sin(\omega t - \pi/2) \text{ Let } i_m = \frac{v_m}{L\omega}, \text{ the current amplitude. Then}$$

$$i = i_m \sin(\omega t - \pi/2)$$

b) No power is developed across the inductor as heat.

c) Resistance of the coil $R = \frac{V}{I} = \frac{100}{1} = 100 \Omega$

Current through the coil when ac source is applied

$$I = \frac{V}{\sqrt{R^2 + X_L^2}}$$

$$\sqrt{R^2 + X_L^2} = \frac{V}{I} = \frac{100}{0.5} = 200 \Omega$$

$$R^2 + X_L^2 = 200^2$$

$$X_L^2 = 200^2 - 100^2$$

$$X_L = 173.2 \Omega$$

$$L\omega = 173.2$$

$$L = \frac{173.2}{\omega} = \frac{173.2}{2\pi f} = \frac{173.2}{2\pi \times 50} = 0.552 H$$

Q4

LO :7.2

Question Text

The current through an AC circuit depends on the magnitude of the applied voltage and impedance of the circuit.

- Write any two factors on which the impedance of a series LCR circuit depends. (1)
- Draw the impedance diagram of a series LCR circuit and write the expression for the power factor from the diagram. (1)
- When 110 V, 50 Hz AC is applied to an electric component labeled X, a current of 0.25 A flows through it and it is in phase with the applied voltage. When X is replaced with another component Y the magnitude of current remains the same but it leads the voltage by $\frac{\pi}{2}$. Identify the components X and Y. Now if X and Y are connected in series with the same source find the current and phase difference between current and voltage. (3)

Scoring Indicators

- Any two factors among inductance, capacitance, resistance and frequency of the applied AC source.

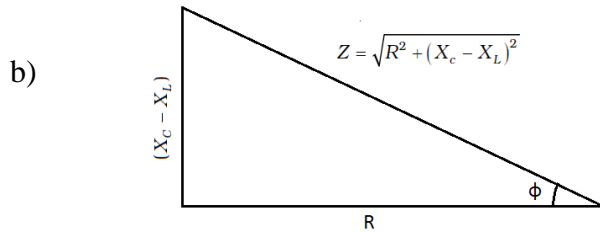

$$\text{Power factor } \cos \phi = \frac{R}{\sqrt{R^2 + (X_C - X_L)^2}}$$

c) X → Resistor Y → capacitor

$$R = \frac{V}{I} = \frac{110}{0.25} = 440 \, \Omega$$

$$X_c = \frac{V}{I} = \frac{110}{0.25} = 440 \, \Omega$$

$$i = \frac{V}{\sqrt{R^2 + X_c^2}} = \frac{110}{\sqrt{440^2 + 440^2}}$$

$$i = 0.1768 \, \text{A}$$

$$\tan \phi = \frac{X_c}{R} = \frac{440}{440} = 1$$

$$\text{Phase difference } \phi = 45^\circ$$

Q5

LO : 7.5

Phasor diagram of a series LCR circuit is shown. V_R , V_L and V_C represent the respective potential difference across resistor, inductor and capacitor and I represents the circuit current. Answer the following questions based on the phasor diagram shown.

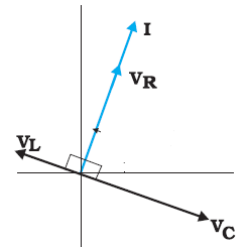

a) In the phasor diagram two quantities have the same phase.

Identify them.

(1)

b) Redraw the given phasor diagram and complete it to show the applied voltage.

(2)

c) Is the frequency applied to the circuit above or below the resonant frequency? (1)

Scoring Indicators

a) Voltage across the resistor (V_R) and Circuit current (I)

b)

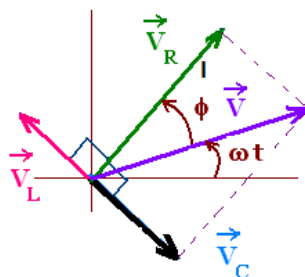

- c) Below the resonant frequency Hint : $L\omega < \frac{1}{C\omega}$

Q6

LO : 7.5

Question Text

110 V variable frequency ac source is applied to a circuit as shown in the figure. At a particular frequency the voltage across the capacitor and inductor are found to be equal.

(Given $L = 0.38$ H, $C = 27$ μ F and $R = 48$ Ω).

- a) Write one practical application of the circuit shown. (1)
- b) Find the current through the circuit. (1)
- c) What is the frequency of the applied ac source? (2)
- d) How does the circuit current change if the plates of the capacitor are
(i) brought closer (ii) moved away? (2)

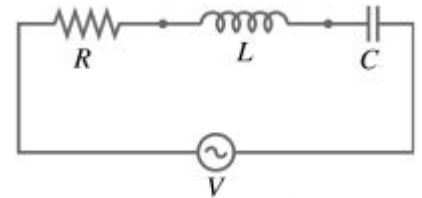
**Scoring Indicators**

- a) Radio tuner
- b) $i_{rms} = \frac{V_{rms}}{Z} = \frac{V_{rms}}{R} = \frac{110}{48} = 2.29$ A
- c) $f = \frac{1}{2\pi\sqrt{LC}} = \frac{1}{2 \times 3.14 \sqrt{0.38 \times 27 \times 10^{-6}}} = 49.7$ Hz
- d) (i) decreases (ii) decreases

Q7



LO : 7.1,7.2,7.3

Question Text

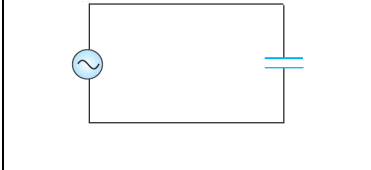
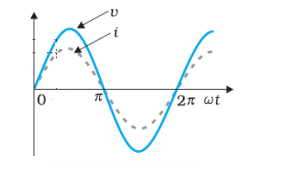

The circuit diagram and the phase relationship between current and voltage for three different circuits are shown in the table below. Match the second and third columns of the table with first column.

(3)

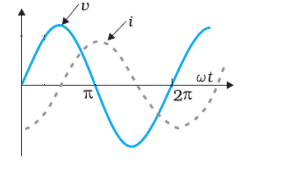
Description	Circuit	Waveform
R only		

L only		
C only		

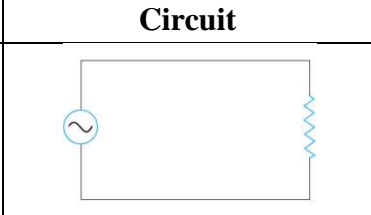
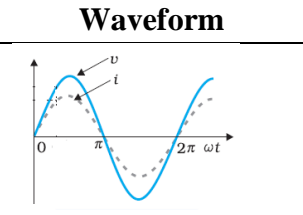
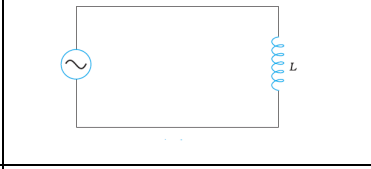
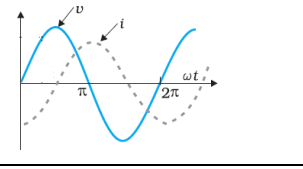
Scoring Indicators

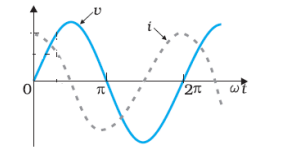
Description	Circuit	Waveform
R only		
L only		
C only		

Q8

LO : 7.9

Question Text

The circuit shown in figure is called tank circuit in which a charged capacitor (C) is connected to an inductor (L).

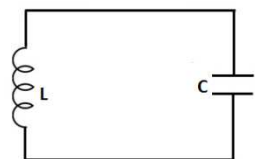

- a) Complete the statement given below.

Capacitor and inductor can store and energy respectively. The charge on the capacitor and the current in the circuit exhibit a phenomenon called

$$\left(\frac{1}{2} + \frac{1}{2} + \right)$$

1)

- b) Figure below shows three different tank circuits. If ω_1, ω_2 and ω_3 are the angular frequencies corresponding to circuits shown in fig (a), fig (b) and fig (c) respectively, choose the correct alternative.

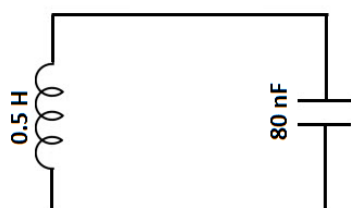

fig (a)

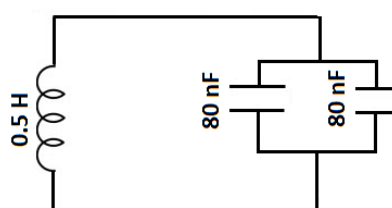

fig (b)

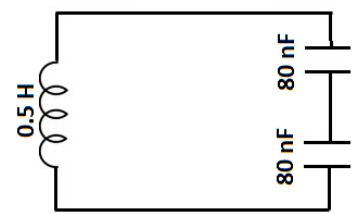

fig (c)

$$\begin{array}{ll}
 \text{(i) } \omega_1 = \omega_2 = \omega_3 & \text{(ii) } \omega_1 < \omega_2 = \omega_3 \\
 \text{(iii) } \omega_2 < \omega_1 < \omega_3 & \text{(iv) } \omega_2 > \omega_1 < \omega_3
 \end{array} \quad (1)$$

Scoring Indicators

- a) Electrical magnetic electrical oscillations
 b) $\omega_2 < \omega_1 < \omega_3$

Q9

LO : 7.9

Question Text

An alternating voltage is connected to a box with some unknown circuit arrangement as shown. The applied voltage and current through the circuit are measured as $v = 80 \sin \omega t$ volt and $i = 1.6 \sin(\omega t + 45^\circ)$ ampere.

- a) Does the current lead or lag the voltage? (1)
 b) Is the circuit in the box largely capacitive or inductive? (1)
 c) Is the circuit in the box at resonance? (1)
 d) What is the average power delivered by the box? (3)

Scoring indicators

- a) Leads
 b) Capacitive
 c) No Hint: Current and voltage are not in the same phase.
 d) $p = V_{rms} I_{rms} \cos \phi$
 $p = \frac{V_m}{\sqrt{2}} \times \frac{I_m}{\sqrt{2}} \times \cos \phi$
 $p = \frac{80}{\sqrt{2}} \times \frac{1.6}{\sqrt{2}} \times \cos 45^\circ$
 $p = 45.25 \text{ W}$

Q10

LO : 7.9

Question Text :

One of the great advantages of ac over dc for electric power distribution is that it is much easier to step the voltage levels up and down with ac than with dc.

- a) Name the device used for the above purpose and write its working principle. (1)
 b) Write any three major energy losses in this device and state how these losses are minimized in a practical situation. (3)

Scoring Indicators:

- a) Transformer. Electromagnetic induction (mutual induction) (1)

Energy Loss	-	Method to minimize the loss
b) Eddy current loss	-	laminated core
Hysteresis loss	-	Soft Iron core
Flux leakage loss	-	winding the primary and secondary coils one over the other.

(3)

Q11

LO : 7.9

Question Text

A friend from abroad presents you a coffeemaker when she visited you. Unfortunately it was designed to operate at 110 V line to obtain 960 W power that it needs.

- Which type of transformer you use to operate the coffeemaker at 220 V? (1)
- Assuming the transformer you use as ideal, calculate the primary and secondary currents. (2)
- What is the resistance of the coffee maker? (1)

Scoring Indicators

- Step down transformer
- Since the transformer is ideal

$$V_p I_p = V_s I_s = 960 \text{ W}$$

$$V_p I_p = 960$$

$$I_p = \frac{960}{220} = 4.36 \text{ A}$$

$$V_s I_s = 960$$

$$I_s = \frac{960}{110} = 8.72 \text{ A}$$

$$\text{c) } R = \frac{V^2}{P} = \frac{110^2}{960} = 12.60 \Omega$$

ELECTROMAGNETIC WAVES**Q 1.**

LO :8.1

Question Text

Maxwell introduced the concept of displacement current which enables to explain the continuous current flow through a circuit.

- a) Explain the concept of displacement current (2)
- b) Give its SI Unit (1)
- c) List out the significance of displacement current. (2)

Scoring Indicator

- a) Current produced by changing electric field.

$$I_d = \epsilon_0 \frac{d\phi_E}{dt}$$

- b) ampere
- c) (1) Electric and magnetic changes with space and time hence the concept of electromagnetic wave can be explained.
- (2) It is a source of magnetic field ie. Changing electric field produces a magnetic field.

Q2.

LO : 8.2

Question Text

The time varying electric and magnetic field will produce an electromagnetic wave. The electric field of an electromagnetic wave is given by

$$E_x = E_0 \sin (kz - \omega t)$$

- a) Write the direction of propagation of electro magnetic wave. (1)
- b) State True or false.

In an electromagnetic wave electric and magnetic vectors are perpendicular to each other.

- (ii) Magnitude of electric and magnetic vectors are same. (2)
- c) The magnetic field of a radio wave can be represented as

$$B = 40 \sin (0.4 \times 10^3 + 2.5 \times 10^{10} t).$$
 What is the amplitude of electric field vector? (1)

Scoring Indicator

(a) Z direction (1)

(b) (i) True

(ii) False

c) $B_0 = 40$

$$C = \frac{E_0}{B_0}$$

$$E_0 = C \times B_0 = 3 \times 10^8 \times 40 = 120 \times 10^8 \text{ N/M}$$

Q3.

LO : 8.3

Question Text

Electromagnetic spectrum is an orderly arrangement of electromagnetic waves according to their wave length/frequency.

a) Arrange the following electromagnetic waves in the ascending order of frequency.

Gamma rays, X-rays, Visible ray, infra red. (1)

b) Match the following (4)

A	B	C
a Infra red	Acceleration of charged particles in a wire	Cancer Treatment
b X-rays	Hot bodies	Water Purifier
c. Radio waves	Transmission of electrons between different energy levels	Radar
d Ultraviolet	Fracture of bones	Remote control
	Magnetron	Cellular Phone

Scoring Indicator

a) Infra red, visible rays, x-rays, gamma rays

b)

A	B	C
a. Infrared	Hot bodies	Remote control
b. X-ray	Fracture of bone	Cancer Treatment
c. Radio waves	Accelerated motion of charges in a wire	Cellular Phone
d. Ultra violet	Transmission of electron between different energy levels	Water Purifier

RAY OPTICS

Qn 1

A ray of light parallel to the principal axis of a spherical mirror falls at a point M as shown in the figure.

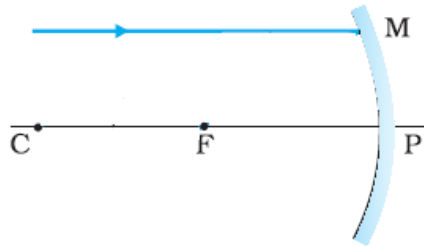

- Identify the type of the mirror used in the diagram.
- If focal length of the mirror is 10 cm, what is the distance CF in the figure?
- Complete the ray diagram and mark the angle of incidence and angle of reflection
- If the mirror is immersed in water its focal length will be
 - less than 10 cm
 - 10 cm
 - greater than 10 cm
 - 20 cm

Scoring Indicators

- Concave mirror
- 10 cm
-

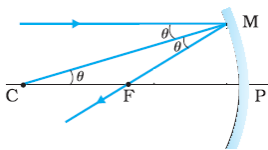

- 10 cm

Qn 2

You are given two mirrors labeled A and B. When you look at them keeping it close to your face a magnified image is seen in mirror A and a diminished image is seen in the mirror B.

- Identify the mirrors A and B (1)
- Draw the ray diagram in which the mirror forms magnified erect image. (2)
- Let the focal length of the mirror you used in the above question is 20 cm. At what distance an object must be placed in front of the mirror so that an image magnified three

times is formed on a screen?

(3)

Scoring indicators

(a) A - Concave mirror

B – Convex Mirror

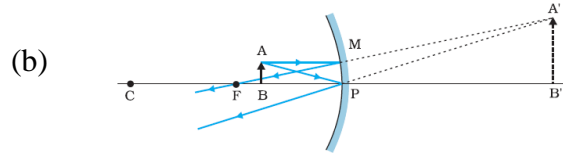

(c) $f = -20 \text{ cm}$ $m = -3$

$$-\frac{v}{u} = -3 \quad v = 3u$$

$$\frac{1}{f} = \frac{1}{v} + \frac{1}{u} = \frac{1}{3u} + \frac{1}{u} = \frac{4}{3u}$$

$$\frac{1}{-20} = \frac{4}{3u} \quad u = \frac{-20 \times 4}{3} = -26.67 \text{ cm}$$

Object is to be placed at a distance of 26.67 cm in front of the mirror.

Q3

Certain prisms are designed to bend light by 90° and by 180° .

(a) These prisms make use of the phenomenon called (1)

(b) Two rays of light — red and blue — are incident on the face AB of a right angled prism ABC. The refractive indices of the material of the prism for red and blue wavelengths are 1.39 and 1.47 respectively. Trace the path of the rays through the prism. (4)

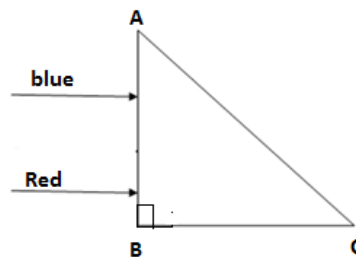

Scoring indicators

(a) Total internal reflection

$$\text{Critical angle for blue light } i_{c(\text{blue})} = \sin^{-1}\left(\frac{1}{1.47}\right) = 42.8^\circ$$

$$\text{Critical angle for red light } i_{c(\text{red})} = \sin^{-1}\left(\frac{1}{1.39}\right) = 46^\circ$$

Because of normal incidence there is no refraction at the face AB. On the face AC of the prism, angle of incidence of both the rays is 45° . Blue light will undergo total internal reflection ($45^\circ > 42.8^\circ$) while red will undergo refraction.

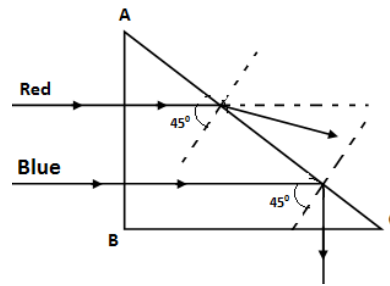

OPTICAL INSTRUMENTS

Q.1.

L.O:9.15

Question text

The given figure shows a simple microscope

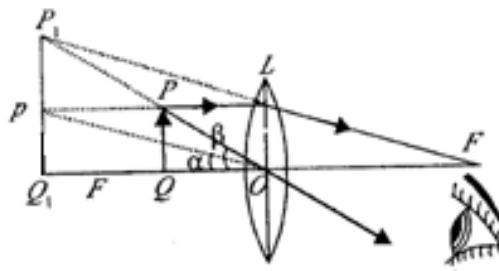

- (a) Identify the object distance and image distance
 (b) Derive an equation for magnifying power of the simple microscope.

Scoring indicators

- (a) Object distance-OQ, image distance-OQ₁
 (b) Magnifying power or magnification is given by

$$\text{magnification, } m = \frac{\text{linear size of the image formed at the least distance of distinct vision}}{\text{linear size of the object}}$$

$$\therefore m = \frac{v}{u} = \frac{D}{u}$$

$$\text{From the lens formula } \frac{1}{v} - \frac{1}{u} = \frac{1}{f}$$

$$\frac{1}{-D} - \frac{1}{-u} = \frac{1}{f} \quad \text{or } -1 + \frac{D}{u} = \frac{1}{f}$$

$$m = 1 + \frac{D}{f}$$

Q.2.

L.O:9.15

Question text

The given figure shows a compound microscope with two lenses PQ and RS

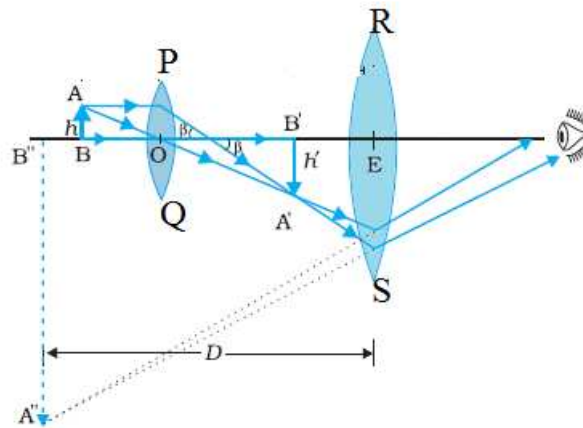

- Identify Objective and eyepiece in the microscope
- A compound microscope has a magnification of 30. The focal length of its eyepiece is 5 cm. Assuming the final image to be formed at the least distance of distinct vision, calculate the magnification produced by the objective.
- What is the length of a compound microscope in normal adjustment.

Scoring indicators

- Objective-PQ, eyepiece-RS
- Magnification , $M = m_o \times m_e$

$$m_e = 1 + \frac{D}{f_e} = 1 + \frac{25}{5} = 6$$

$$m_o = \frac{m_e}{M} = \frac{30}{6} = 5$$

- The length of a compound microscope in normal adjustment is $v_o + f_e$

Q.3.

L.O:9.15

Question text

A compound microscope consists of an objective lens of focal length 2 cm and an eyepiece of focal length 6.25 cm separated by a distance of 15 cm. How far from the objective should an object be placed in order to obtain the final image at

- least distance of distinct vision

(b) infinity

Scoring indicators

(a) $v_e = -25\text{cm}$

$$\frac{1}{u_e} = \frac{1}{v_e} - \frac{1}{f_e} = \frac{1}{-25} - \frac{1}{6.25} \quad \therefore u_e = 5\text{cm}$$

Length of the tube, $L = |v_o| + |u_e|$

$$\therefore v_o = 15 - 5 = 10$$

$$\frac{1}{u_o} = \frac{1}{v_o} - \frac{1}{f_o} = \frac{1}{10} - \frac{1}{2} \quad u_o = -2.5\text{cm}$$

(b) $\therefore v_o = 15 - f_e = 15 - 6.25 = 8.75$

$$\frac{1}{u_o} = \frac{1}{v_o} - \frac{1}{f_o} = \frac{1}{8.75} - \frac{1}{2} \quad u_o = -2.59\text{cm}$$